

2003 ANNUAL TECHNICAL REPORT



SAN JOAQUIN RIVER GROUP AUTHORITY



Salmon Smolt Released at Durham Ferry, April 21, 2003

2003 ANNUAL TECHNICAL REPORT

on Implementation and Monitoring
of the San Joaquin River Agreement and
the Vernalis Adaptive Management Plan

Prepared by

San Joaquin River Group Authority

Prepared for the

California Water Resources Control Board

in compliance with D-1641

January 2004

TABLE OF CONTENTS

EXECUTIVE SUMMARY	3
CHAPTER 1:	
Introduction	7
<i>Experimental Design Elements</i>	7
CHAPTER 2:	
VAMP Hydrologic Planning & Implementation	9
<i>VAMP flow and SWP/CVP Exports</i>	9
<i>Hydrologic Planning</i>	10
<i>Implementation</i>	12
<i>Results of Operations</i>	15
CHAPTER 3:	
Additional Water Supply Arrangements & Deliveries	20
<i>Merced Irrigation District</i>	20
<i>Oakdale Irrigation District</i>	20
CHAPTER 4:	
Head of Old River Barrier	22
<i>Barrier Design, Installation and Operation</i>	22
<i>Materials and Methods</i>	29
<i>Results</i>	31
<i>Discussion</i>	34

CHAPTER 5:	
Salmon Smolt Survival Investigations	37
<i>Coded-Wire Tagging</i>	37
<i>Coded-Wire Tag Releases</i>	37
<i>Water Temperature Monitoring</i>	39
<i>Post-Release Net Pen Studies</i>	41
<i>Coded-Wire Tag Recovery Efforts</i>	44
<i>VAMP Chinook Salmon CWT Survival</i>	46
<i>Transit Time</i>	50
<i>Comparison with Past Years</i>	51
<i>Ocean Recovery Information from Past Years</i>	57
<i>San Joaquin River Salmon Protection</i>	60
<i>Summary & Recommendations</i>	66
CHAPTER 6:	
Complimentary Studies Related to the VAMP	72
<i>Survival Estimates for the Tributaries</i>	72
<i>Evaluation of Chinook Salmon Fry Survival</i>	72
<i>Radio Tagging Studies in the Lower River</i>	77
CHAPTER 7:	
Conclusions & Recommendations	82
References Cited	84
Contributing Authors	85
Signatories to the San Joaquin River Agreement	86
Useful Web Pages	87
Acronyms & Abbreviations	88
APPENDICES	89

EXECUTIVE SUMMARY

The San Joaquin River Agreement (SJRA) is the cornerstone of a history-making commitment to implement the State Water Resources Control Board (SWRCB) 1995 Water Quality Control Plan (WQCP) for the lower San Joaquin River and the San Francisco Bay—Delta Estuary (Bay—Delta). Using a consensus-based approach, the SJRA united a large and diverse group of agricultural, urban, environmental and governmental interests. [📄](#)

The 2003 Annual Technical Report comprises the consolidated annual SJRA Operations Report and Vernalis Adaptive Management Plan (VAMP) Monitoring Report. The VAMP 2003 program represents the fourth year of formal compliance with SWRCB Decision 1641 (D-1641). D-1641 requires the preparation of an annual report documenting the implementation and results of the VAMP program. [📄](#) Specifically, this report includes the following information on the implementation of the SJRA: the hydrologic chronicle; management of the additional SJRA water; installation, operation, and monitoring of the Head of Old River Barrier (HORB); results of the juvenile Chinook salmon smolt survival investigations; discussion of complementary investigations; and, conclusions and recom-



The 2003 Annual Technical Report comprises the consolidated annual SJRA Operations Report and Vernalis Adaptive Management Plan (VAMP) Monitoring Report.

mendations. Condition 4.b of D-1641 directs the Department of Water Resources (DWR) and the U.S. Bureau of Reclamation (USBR) to send the Executive Director of the State Board the results of the fishery monitoring studies on an annual basis and Condition 7 of D-1641 directs Merced, Modesto, Turlock, South San Joaquin and Oakdale irrigation districts to submit a report detailing district operations as a result of the SJRA. By letter dated September 8, 2000, the SWRCB approved combining these two reports into a single comprehensive report due the SWRCB on January 31 of each year.

A key part of this landmark agreement is the VAMP. VAMP is designed to protect juvenile Chinook salmon migrating from the San Joaquin River through the Sacramento—San Joaquin Delta. VAMP is also a scientifically recognized experiment to determine how salmon survival rates change in response to alterations in San Joaquin River flows and State Water Project (SWP)/Central Valley Project (CVP) exports with the installation of the HORB. [📄](#)

VAMP employs an adaptive management strategy to use current knowledge of hydrology and environmental conditions to protect Chinook salmon smolt passage, while gathering information to allow more efficient protection in the future. In addition to providing improved protection for juvenile Chinook salmon emigrating from the San Joaquin River system, specific experimental objectives of VAMP 2003 included:

- Quantification of Chinook salmon smolt survival from Durham Ferry and Mossdale to Jersey Point using recapture locations at Antioch and Chipps Island, under conditions of a San Joaquin River flow at Vernalis of 3,200 cfs, with an installed HORB, and SWP/CVP export rates of 1,500 cfs; and
- Comparison of juvenile Chinook salmon survival between Durham Ferry and Mossdale for use in comparing results of VAMP 2003 with results from earlier survival studies where coded-wire tagged salmon releases occurred at Mossdale.

[📄](#) See Useful Web Pages

The VAMP 2002 Annual Technical Report presented a series of conclusions and recommended modifications to the VAMP experimental design and/or program implementation.  The 2002 recommendations were used, in part, as the basis for developing the 2003 VAMP test program. For example, the 2002 report recommended weekly measurements of San Joaquin River flow at the Vernalis gage, continued hydrology investigations to estimate ungaged flows (accretions, depletions) to improve hydrologic predictions, and continued coordination among tributary operators to facilitate implementation of the VAMP test flow conditions. As part of the 2003 program, the hydrology technical committee, working in cooperation with tributary operators and USGS, was able to improve our understanding of San Joaquin River hydrology, provide measurements of Vernalis flow, and provide effective coordination of releases from upstream tributaries. The 2002 report also recommended modifications to the Head of Old River Barrier (HORB) and entrainment monitoring program including a delay in salmon releases at Durham Ferry and Mossdale for approximately five days after barrier closure to allow time for gravel and rock to flush from the culverts and improve fishery sampling, measure flows within the culverts, continue monitoring to evaluate potential impacts of seepage, monitor fish entrainment at the culverts, and improve the experimental design of Head of Old River Barrier investigations. These recommendations were addressed as part of the 2003 VAMP program through delayed salmon releases at Durham Ferry and Mossdale after barrier closure, continued water level monitoring to refine the operational criteria for the culverts and evaluate potential seepage through groundwater well monitoring, and improved fisheries monitoring at the culverts to provide information on the percentage of VAMP CWT salmon released at Mossdale and Durham Ferry, in addition to unmarked salmon, subsequently entrained into the barrier culverts. The Department of Water Resources (DWR) was successful in securing all of the necessary permits and approvals for the installation of the Head of Old River Barrier over the next five years. However, landowner access remains to be negotiated annually.

A quality assurance/quality control program has been used as a routine part of VAMP tests. The 2003 CWT tagging at the Merced River Fish Facility included information useful in quantifying CWT retention and tag efficiency. During the 2003 program, coordination with the local landowner was continued to curtail operation of an agricultural diversion pump located



Recommendations from the 2002 VAMP program were used to improve the overall experimental design and implementation of the 2003 VAMP investigations.

immediately downstream of Durham Ferry, coincident with each of the two releases. In addition, the 2003 VAMP program continued use of the net pen studies and a fish health assessment to determine the health and survival of test fish released as part of VAMP. Additional measurements are needed of flow passing through the Head of Old River Barrier culverts and in the San Joaquin River downstream of the confluence with Old River. In the future measurements of San Joaquin River flow downstream of the Old River Barrier will be used in the relationship between San Joaquin River flow and juvenile Chinook salmon survival. Additional complimentary studies, including survival studies for juvenile Chinook salmon emigrating from San Joaquin River tributaries, were incorporated into the 2003 VAMP investigations.

The estimated survival of CWT salmon released from Durham Ferry and Mossdale was the lowest measured to date and the lowest since initiation of the VAMP. An elevated percentage of Proliferative Kidney Disease when combined with low flow conditions may have contributed to an increase in mortality but it is uncertain based on only the 2003 data. The 2002 report recommended that, to the extent possible, VAMP survival testing be conducted at flow and export extremes to improve the ability of the program to detect differences in juvenile Chinook salmon survival among target flow and export condi-

tions. Hydrologic conditions within the San Joaquin River watershed did not provide conditions suitable for testing extreme target conditions as part of the VAMP 2003 program. These and other recommendations from the 2002 VAMP program were used to improve the overall experimental design and implementation of the 2003 VAMP investigations. Recommendations made based upon analyses of the VAMP 2003 program will also be used, in a similar way, by the hydrology and fisheries technical committees in developing and implementing the experimental design for the 2004 VAMP studies.

Based on data gathered during the experimental mark-recapture studies that occurred over a 31-day period in April and May 2003, a set of conclusions and recommendations has been developed. These conclusions and recommendations provide guidance and a foundation for design and implementation of future VAMP operations. Key conclusions and recommendations derived from VAMP 2003 include:

- VAMP 2003 is the fourth year of full implementation of the program. Average Vernalis flow during the VAMP period was 3,235 cfs. SWP and CVP export rates averaged 1,446 cfs. The VAMP period was between April 15 and May 15, 2003.
- Recovery rates of the Durham Ferry and Mossdale groups relative to the Jersey Point groups using recaptures at Antioch and Chipps Island indicated that there was no statistical ($p > 0.05$) difference between the two replicates or release locations in 2003. The number of CWT salmon recovered from the second set of release groups, however, was lower than recoveries from the first release groups with no recoveries made for the second Durham Ferry release group at either Antioch or Chipps Island. The second set of release groups was found to have a significantly higher incidence of PKD infection, than the first set of releases.
- The combined differential recovery rate of CWT salmon recovered from Durham Ferry and Mossdale groups relative to the Jersey Point groups showed that the relative survival in 2003 was significantly lower than survival results from the 2002 VAMP although flow and export conditions (target flow 3200 cfs and exports of 1500 cfs in both years) were comparable for the two years. The factors contributing to the significantly lower survival in 2003 are unknown, although may be related to the combined effects of PKD infection and the lower flows.
- The relationships between salmon survival, Vernalis flow, and SWP/CVP exports are no longer statistically significant.

- Streamflow data at Vernalis were improved by weekly flow measurements and rating curve verification, however estimation of ungaged flow (accretions and depletions) requires further investigation for use in establishing annual VAMP target flows. Alternative methods of measuring flow at Vernalis and/or alternative measurement locations should also be investigated. DWR installed a stage recorder and fixed acoustic Doppler velocity meter in the San Joaquin River downstream of the confluence with Old River for use in measuring river flow. The monitoring station is being calibrated and is anticipated to be available for flow measurements associated with the VAMP 2004 studies.
- The design, construction, and operation of the HORB were successful in 2003. Salmon releases at Durham Ferry and Mossdale were delayed approximately five days after HORB closure to allow time for gravel and rock to flush from the culverts and to assure the safety of personnel conducting fisheries sampling at the site. Operation of the HORB with three culverts open was successful in maintaining south Delta water levels.
- The index of salmon entrainment at the HORB in 2003 with three culverts open was substantially greater than in 2001 and 2002 with all six culverts open.
- Construction of multiple barriers within the south Delta during the spring has the potential to delay completion of the construction of HORB, which may contribute to exposure of juvenile Chinook salmon to elevated water temperatures. Due to the high risk of losing major salmon protection benefits and biasing experimental conditions, it is strongly recommended that construction of the HORB be completed on schedule to avoid delays in implementing survival investigations. The report also recommends that flow measurements be made to document flow through HORB culverts and the resultant flow within the San Joaquin River downstream of the confluence with Old River.
- The variability inherent in measuring salmon smolt survival in the lower San Joaquin River and Delta makes it difficult to detect statistically significant differences in salmon survival between VAMP flow and export target conditions, which are relatively similar. It is strongly recommended that, conditions be tested at 7000 cfs flow and 1500 cfs export to improve ability to detect potential differences in salmon smolt survival among test conditions.

- Approximately 80 percent of the unmarked salmon migrating past Mossdale in 2003 migrated during the VAMP period (April 15 through May 15) and were, therefore protected by increased San Joaquin River flow, installation of the HORB and decreased export pumping.
- The selection and management of VAMP flow conditions should, if possible, minimize or avoid requiring upstream tributary flows that adversely affect potential habitat quality or survival of natural salmon produced within the tributaries. It is therefore recommended that upstream tributary and VAMP studies be coordinated as much as possible. Coordination during 2003 with upstream tributary operations was successful and coordination among tributary operators should continue in the future.
- The report encourages expansion of complementary studies to provide additional information on factors and mechanisms affecting salmon survival during migration from the lower San Joaquin River through the delta.
- Past data indicates that survival improves as flows increase and flows relative to exports increase. With the addition of the 2003 data the relationships between salmon survival rates and Vernalis flow and flow relative to SWP/CVP export conditions are no longer statistically significant. The VAMP program provides improved protection for juvenile salmon when compared to “pre-VAMP” conditions. Further tests, over a wider range of flow and export conditions, are needed to evaluate the respective roles of San Joaquin River flow and SWP/CVP exports on juvenile Chinook salmon smolt survival. The report recommends that the VAMP experimental test program be continued.



The relationships between salmon survival rates and Vernalis flow and flow relative to SWP/CVP export conditions are no longer statistically significant. The VAMP program provides improved protection for juvenile salmon when compared to “pre-VAMP” conditions. The report recommends that the VAMP experimental test program be continued.

CHAPTER 1

Introduction

Actions associated with the Vernalis Adaptive Management Plan (VAMP) were implemented between April 15 and May 15, 2003 to protect juvenile Chinook salmon and evaluate the relationship between San Joaquin River flow and State Water Project (SWP) and federal Central Valley Project (CVP) water project exports on the survival of marked juvenile Chinook salmon migrating through the Sacramento-San Joaquin Delta. Studies conducted in 2003, represent the fourth year of the VAMP experiment. Results from previous VAMP experiments are available in San Joaquin River Agreement 2000 Technical Report and San Joaquin River Group Authority, Technical Reports 2001 and 2002. Similar experiments were conducted prior to the official implementation of VAMP with results available in South Delta Temporary Barriers Annual Reports (DWR, 2001, 1999, 1998). This report will describe the experimental design of VAMP, the hydrologic planning and implementation, the additional water supply arrangements and deliveries, the Head of Old River Barrier (HORB) design, installation, operation and fisheries monitoring, the smolt survival investigation and complimentary studies related to VAMP. Conclusions and Recommendations for future VAMP studies are also included.

EXPERIMENTAL DESIGN ELEMENTS

The VAMP experimental design measures salmon smolt survival through the Delta under six different combinations of flow and export rates. The experimental design includes two mark-recapture studies performed each year during the mid-April to mid-May juvenile salmon outmigration period that provide estimates of salmon survival under each set of conditions. Chinook salmon survival indices under each of the experimental conditions are then calculated based on the numbers of marked salmon released and the number recaptured. Absolute survival

estimates and combined differential recovery rates were also calculated and used in relationships between survival and San Joaquin River flow and CVP and SWP exports.

The VAMP 2003 experimental design included both multiple release locations (Durham Ferry, Mossdale, and Jersey Point), and multiple recapture locations (Antioch, Chipps Island, SWP and CVP salvage operations, and in the ocean fisheries; Figure 1-1). Two sets of releases were made at Durham Ferry, Mossdale, and Jersey Point. The use of data from multiple release and recapture locations allows for a more thorough evaluation of juvenile Chinook salmon survival as compared to recapture data from only one sampling location and/or one series of releases. The VAMP coded-wire tag (CWT) releases (Durham Ferry, Mossdale, and Jersey Point) and recapture locations (Antioch and Chipps Island) are consistent from one year to the next, providing a greater opportunity to assess salmon smolt survival over the range of Vernalis flows, SWP/CVP exports, and with and without the presence of the Head of Old River Barrier (HORB). Releases at Jersey Point serve as controls for recaptures at Antioch and Chipps Island, thereby allowing the calculation of survival estimates based on the ratio of survival indices from marked salmon recaptured from upstream (e.g., Durham Ferry and Mossdale) and downstream (control release at Jersey Point) releases. The combined differential recovery rates are calculated in a similar manner. The use of ratio estimates as part of the VAMP study design factors out the potential differential gear efficiency at Antioch and Chipps Island within and among years.

The added recovery numbers from recapturing marked fish at both Antioch and Chipps Island improves the precision associated with the individual survival estimates, and improves confidence in detecting differences in salmon smolt survival as a function of Vernalis flows and SWP/CVP exports.

A quality assurance/quality control program has been used as a routine part of VAMP tests, and includes quantifying the number of marked fish successfully clipped and tagged. Coordination with the local landowner to curtail operation of an agricultural diversion pump located immediately downstream of Durham Ferry, coincident with each of the two Durham Ferry releases was continued in 2003. In addition, the 2003 VAMP program continued use of the net pen studies and

physiological testing to assess overall condition and health of marked fish used in VAMP experiments. Additional improvements are needed relative to measuring and reporting flow in San Joaquin River downstream of the confluence with Old River. Measurements of San Joaquin River flow downstream of the HORB will be used to evaluate the relationship between San Joaquin River flow and juvenile Chinook salmon survival in the future.

FIGURE 1-1
Sacramento—San Joaquin Estuary



Location of VAMP 2003 Release Sites (Durham Ferry, Mossdale and Jersey Point), Recovery Locations (Antioch and Chipps Island), and Head of Old River Barrier Location Within the Sacramento-San Joaquin River Delta/Estuary.

CHAPTER 2

VAMP Hydrologic Planning & Implementation

This section documents the planning and implementation undertaken by the Hydrology Group of the San Joaquin River Technical Committee (SJRTC) for the 2003 VAMP investigations. Implementation of VAMP is guided by the framework provided in the San Joaquin River Agreement (SJRA) and anticipated hydrologic conditions within the watershed.

The Hydrology Group was established for the purpose of forecasting hydrologic conditions and for planning, coordinating, scheduling and implementing the flows required to meet the test flow target in the San Joaquin River near Vernalis. The Hydrology Group is also charged with exchanging information relevant to the forecasted flows, and coordinating with others in the SJRTC, in particular the Biology Group, responsible for planning and implementing the salmon smolt survival study.

Participation in the Hydrology Group is open to all interested parties, with the core membership consisting of the designees of the agencies responsible for the water project operations that would be contributing flow to meet the target flow. In 2003, the agencies belonging to the Hydrology Group included: Merced Irrigation District (Merced), Turlock Irrigation District (TID), Modesto Irrigation District (MID), Oakdale Irrigation District (OID), South San Joaquin Irrigation District (SSJID), San Joaquin River Exchange Contractors Water Authority (SJREC), and the U.S. Bureau of Reclamation (USBR). Though not a water provider, the California Department of Water Resources (DWR) was closely involved with the coordination of operations relating to the installation of the HORB and the planning of Delta exports consistent with the VAMP.

VAMP FLOW AND SWP/CVP EXPORTS

The VAMP provides for a 31-day pulse flow (target flow) in the San Joaquin River at the Vernalis gage during the months of April and May, along with a corresponding reduction in SWP/CVP exports, as shown in Table 2-1. The magnitude of the pulse flow is based on flow that would occur during the pulse period absent the VAMP, referred to as the existing flow.

As part of the development of the VAMP experimental design, the VAMP Hydrology and Biology Groups jointly identified a level of variation in San Joaquin River flow and SWP/CVP export rate thought to be within an acceptable range for specific VAMP test conditions. In developing the criteria, the VAMP Hydrology and Biology Groups examined both the ability to effectively monitor and manage flows and exports within various ranges (e.g., the ability to accurately manage and regulate export rates is substantially greater than the ability to manage San Joaquin River flows) and the flow and export differences among VAMP targets (Table 2-1). Through these discussions, the technical committees agreed that SWP/CVP export rates would be managed to a level of plus or minus 2.5% of a given export rate target. Furthermore, the technical committees agreed that, to the extent possible, it would be desirable that exports be allocated approximately evenly between SWP and CVP diversion facilities.

TABLE 2-1
VAMP Vernalis Flow and Delta Export Targets

Existing Flow (cfs)	VAMP Target Flow (cfs)	Delta Export Target Rates (cfs)
0 to 1,999	2,000	
2,000 to 3,199	3,200	1,500
3,200 to 4,449	4,450	1,500
4,450 to 5,699	5,700	2,250
5,700 to 7,000	7,000	1,500 or 3,000
Greater than 7,000	Provide stable flow to extent possible	

The ability to manage and regulate San Joaquin River flows is difficult due to variation in unregulated flows, uncertainty in real-time flows due to changing channel conditions, lags and delays in transit time, and a variety of other factors. Concern was expressed that variation in San Joaquin River flow on the order of plus or minus 10% would potentially result in overlapping flow conditions between two VAMP targets. To minimize the probability of overlapping flow conditions among VAMP targets, the technical committees explored an operational guideline of plus or minus 5% flow variation at the Vernalis gage; however, system operators expressed concern about the ability to maintain flows within this range. As a result of these discussions and analysis, the joint Hydrology and Biology Groups agreed to a target range variation of plus or minus 7% of the Vernalis flow target. It was recognized by the Hydrology and Biology Groups that these guidelines were not absolute conditions, but was to be used by the VAMP hydrology and biology workgroups to evaluate experimental test conditions and the potential effect of flow and export variation on our ability to detect and assess variation in juvenile Chinook salmon survival rates among VAMP test conditions.

Under the SJRA, the following SJRGA agencies have agreed to provide the supplemental water, limited to a maximum of 110,000 acre-feet, needed to achieve the VAMP target flows shown in Table 2-1: Merced, OID, SSJID, SJREC, MID and TID.

The 2,000 cubic feet per second (cfs) VAMP target flow shown in Table 2-1 does not represent a VAMP experiment data point but is used to define the supplemental water volume to be provided by the SJRGA agencies in critically dry years when existing flow is less than 2,000 cfs. In preparation of the conceptual framework for the VAMP it was recognized that in extremely dry conditions the San Joaquin River flow and associated exports would be determined in accordance with the existing biological opinions under the Endangered Species Act and the 1994 Bay-Delta Accord. In consideration of these factors, when the existing flow is less than 2000 cfs, the USBR, in accordance with the SJRA, shall act to purchase additional water from willing sellers to fulfill the requirements of existing biological opinions.

Based upon hydrologic conditions, the target flow in a given year could either be increased to the next highest value (“double-step”) or the supplemental water requirement could be eliminated entirely. A numerical procedure has been established in the SJRA to determine the target flow. The SWRCB San Joaquin Valley Water Year Hydrologic Classification (“60-20-20” classification) is given a numerical indicator as shown in Table 2-2.

TABLE 2-2
San Joaquin Valley Water Year Hydrologic Classifications Used in VAMP

60-20-20 Water Year Classification	VAMP Numerical Indicator
Wet	5
Above Normal	4
Below Normal	3
Dry	2
Critical	1

“Double-step” flow years occur when the sum of last year’s numerical indicator and the 90 percent exceedence forecast of the current year’s numerical indicator is seven (7) or greater.

If the sum of the two previous years’ numerical indicators and the 90 percent exceedence forecast of the current year’s numerical indicator is four (4) or less, indicative of an extended dry period, no VAMP supplemental water will be provided. The USBR, however, has a continuing obligation to meet San Joaquin River flows pursuant to the March 6, 1995 Delta smelt Biological Opinion.

Under the SJRA, the maximum amount of supplemental water to be provided to meet VAMP target flows in any given year is 110,000 acre-feet. Based on the targets outlined in Table 2-1, in a double-step year up to 157,000 acre-feet of supplemental water may be required. If the VAMP target flow requires more than 110,000 acre-feet of supplemental water, then additional water may be acquired on a willing seller basis.

HYDROLOGIC PLANNING

Hydrology Group Meetings

Beginning in February 2003, and continuing until early April, the Hydrology Group held four planning and coordination meetings (February 19, March 12, March 26 and April 9). At these meetings, forecasts of hydrologic and operational conditions on the San Joaquin River and its tributaries were discussed and refined.

Monthly Operation Forecasts

As part of the early planning efforts, monthly operation forecasts were developed by the Hydrology Group to estimate the existing flow at Vernalis. Inflows to the tributary reservoirs used in these forecasts were based on DWR Bulletin 120 runoff forecasts. The monthly operation forecasts used the 90 percent and 50 percent probability of exceedence runoff forecasts. The

initial monthly operation forecast was presented at the February 19 Hydrology Group meeting. The 90 percent exceedence forecast called for a VAMP target flow of 3,200 cfs and the 50 percent exceedence forecast called for a VAMP target flow of 5,700 cfs. Hydrologic projections and planning were subsequently refined as additional information became available in March and April.

Daily Operation Plan

Starting in mid-March, the Hydrology Group began development of a daily operation plan, updating it as hydrologic conditions and operational requirements changed. The daily operation plan calculated an estimated mean daily flow at Vernalis based on estimates of the daily flow at the major tributary control points, estimates of ungauged flow between those control points and Vernalis, and estimates of flow in the San Joaquin River above the major tributaries. The following key assumptions were used in the development of the daily operation plan:

(1) The travel times for flows from the tributary control points and upper San Joaquin River to the Vernalis gauge are assumed as follows:

- | | |
|---|--------|
| a. Merced River at Cressey to Vernalis | 3 days |
| b. San Joaquin River above Merced River to Vernalis | 2 days |
| c. Tuolumne River at LaGrange to Vernalis | 2 days |
| d. Stanislaus River below Goodwin Dam to Vernalis | 2 days |

(2) Based upon a review of the historical flow record, the ungauged flow at Vernalis was assumed to be constant throughout the VAMP period and based upon the value entering the period. By definition, the ungauged flow is the unmeasured flow entering the system between Vernalis and the upstream measuring points and is calculated as follows:

Vernalis Ungauged =

$$\text{VNS} - \text{GDWlag} - \text{LGNlag} - \text{CRSlag} - \text{USJRIag}$$

where:

- | | |
|---------|--|
| VNS | = San Joaquin River near Vernalis |
| GDWlag | = Stanislaus River below Goodwin Dam lagged 2 days |
| LGNlag | = Tuolumne River below LaGrange Dam lagged 2 days |
| CRSlag | = Merced River at Cressey lagged 3 days |
| USJRIag | = San Joaquin River above Merced River lagged 2 days (USJR is not a gauged flow but is the calculated difference between the gauged flows at the San Joaquin River at Newman (NEW) and the Merced River near Stevinson (MST)). |

By definition, the VAMP 31-day pulse flow period can occur anytime between April 1 and May 31. Factors needed to be considered in determining the timing of the VAMP period include installation of the HORB, availability of juvenile salmon at the hatchery, and manpower and equipment availability for salmon releases and recapture. Until a specific start date is defined, a default target flow period of April 15 to May 15 is used for the VAMP operation planning. The current installation and operational constraints for the HORB are described in Chapter 4.

The previous two years, 2001 and 2002, were both classified as “dry” years using the 60-20-20 water year classification, giving each a VAMP numerical indicator of two. Therefore, there was no possibility of 2003 being a dry period off-ramp year (numerical indicator of previous two plus current year total of 4 or less). Conversely, in order for 2003 to be a “double-step” year, 2003 would need to be classified as a “wet” year based on the 90 percent exceedence forecast as of April 1, with a VAMP numerical indicator of 5. The early 90% exceedence forecasts (Jan., Feb. and Mar.) were indicating a “dry” or “critical” year, making it very unlikely that 2003 would be a “double-step” year; therefore, planning efforts concentrated on the “single step” criteria. In fact, the 90% exceedence forecast on April 1 for the San Joaquin Valley was for a “critical” year, resulting in the 2003 VAMP following the “single step” criteria.

The initial Daily Operation Plan was prepared on March 12, and was modified as hydrologic conditions and operational requirements changed. Table 2-3 summarizes the various iterations of, and demonstrates the evolutionary nature of the daily operation plan. Copies of the daily operation plans are provided in Appendix A-1.

The SJRTC Biology Group was interested in setting a VAMP target flow start date earlier than April 15. DWR noted that due to regulatory and construction limitations it was highly unlikely that the HORB could be closed prior to April 15, but that it was on schedule for closure by April 15. Therefore the period of April 15 through May 15 was designated as the target flow period.

Normally, the USGS measures the flow at Vernalis to check the current rating shift on a monthly basis. The real-time flows reported by the USGS and CDEC are dependent on the most current rating shift, therefore a new measurement and shift can result in a sudden and significant change in the reported real-time flow. In order to minimize the potential for these sudden and significant changes, arrangements were made with the USGS to measure the flow at Vernalis on a weekly basis between April 2 and May 7. The results of these measurements



Although the primary goal of the VAMP operation is to provide a stable target flow in the San Joaquin River near Vernalis, an important consideration in the operation is that the flows scheduled on the Merced, Tuolumne and Stanislaus Rivers to achieve this goal do not conflict with studies or flow requirements on the individual tributaries, and to the degree possible, provide benefits on the tributaries.

are summarized in Table 2-4. A shift was applied to the Vernalis rating curve as a result of the April 16 measurement, which indicated that the actual flow was approximately 150 cfs higher than what was being reported real-time (3,040 cfs actual flow versus 2,890 cfs reported flow). This shift did not result in any changes to the planned VAMP operation.

Tributary Flow Coordination

Although the primary goal of the VAMP operation is to provide a stable target flow in the San Joaquin River near Vernalis, an important consideration in the operation is that the flows scheduled on the Merced, Tuolumne and Stanislaus Rivers to achieve this goal do not conflict with studies or flow requirements on the individual tributaries, and to the degree possible, provide benefits on the tributaries. During the development of the daily operation plan, the Hydrology group consults with DFG and the tributary biological teams to determine periods of time when stable flows are desirable on the tributaries, what flow rates are desired, and what flow limitation exist, specifically in regards to ramping, minimum and maximum flows.

The periods of desired stable flow are highlighted with bold outlines in the daily operation plans in Appendix A-1.

For the 2003 VAMP operation there were two periods of desired stable flow on the Merced River, one on the Stanislaus River, but none on the Tuolumne River. On the Merced River the desire was to have a period with a stable flow of about 500 cfs and a stable pulse flow in excess of 1000 cfs for a period of 8 to 9 days. On the Stanislaus River the desire was to have a pulse flow of 1500 cfs for as long a period as possible. The coordination of these desired flows resulted in an initial pulse in the Tuolumne River, followed by an eight day 1500 cfs pulse flow on the Stanislaus, which was followed by an eight day 1500 cfs pulse flow on the Merced River. Plots of the individual tributary flows are provided in Appendix A-3.

IMPLEMENTATION

Operation Conference Calls

During implementation of the VAMP pulse flow, conference calls were conducted on a regular basis among members of the Hydrology Group and SJRGA member staff to discuss the status of the pulse flow and to make changes to the operation plan if needed. The calls were held at 6:30 a.m. so that potential operational changes could be implemented on that day. The conference calls were held every Monday, Wednesday and Friday, starting on April 16 and ending on May 9.

Operation Monitoring

The planning and implementation of the VAMP spring pulse flow operation was accomplished using the best available real-time data from the sources listed in Table 2-5. The CDEC real-time data has not been reviewed for accuracy or adjusted for rating shifts; the USGS real-time data has had some preliminary review and adjustment. During the VAMP flow period, the real-time flows at Vernalis and in the San Joaquin River tributaries were continuously monitored. Similarly, the computed ungaged flow at Vernalis and the flow in the San Joaquin River upstream of the Merced River were continuously updated.  The monitoring was necessary to verify that supplemental water deliveries were adhering to tributary allocations contained in the SJRA Division Agreement to the extent possible, as well as to determine if changes in hydrologic conditions would require changes to the operation plan.

The daily operation plan was updated throughout the VAMP flow period. A summary of the updated daily operation plans is provided in Table 2-6. Copies of the updated daily operation plans are provided in Appendix A-2.

TABLE 2-3
Summary of Daily Operation Plans Prepared During Planning Phase

VAMP Forecast Date	VAMP Target Flow Period	Assumed Ungaged Flow at Vernalis (cfs)*	Existing Flow (cfs)*	VAMP Target Flow (cfs)*	Supplemental Water needed to meet Target Flow (1,000 AF)*
March 12	April 15 - May 15	300 - 600	2,070 - 2,980	3,200	69.42 - 13.67
March 26	April 15 - May 15	300 - 500	2,280 - 2,840	3,200	56.70 - 22.22
April 4	April 15 - May 15	400	2,565	3,200	39.06
April 9	April 15 - May 15	300	2,340	3,200	52.91

*Figures represent the most probable range of low and high hydrologic conditions.

TABLE 2-4
Summary of USGS Flow Measurements at the San Joaquin River near Vernalis Gage

Date	River Stage (ft)	Measured Flow (cfs)	CDEC Reported Real-time Flow (cfs)	Percent Difference	Rating Shift
March 4 (9:22)	9.87	2,140	2,150	-0.5%	No
April 2 (10:09)	9.68	2,070	2,000	3.5%	No
April 9 (9:46)	9.6	2,000	1,950	2.6%	No
April 16 (10:00)	10.74	3,040	2,890	5.2%	Yes
April 23 (9:17)	11.07	3,320	3,350	-0.9%	No
April 30 (10:01)	11.04	3,390	3,320	2.1%	No
May 7 (9:50)	10.92	3,100	3,210	-3.4%	No

TABLE 2-5
Real-time Flow Data and Sources

Measurement Location	Real-time Data Source
San Joaquin River near Vernalis	USGS, station 11303500 (http://waterdata.usgs.gov/ca/nwis/dv?format=pre&period=31&site_no=11303500)
Stanislaus River below Goodwin Dam	USBR, Goodwin Dam Daily Operation Report (http://www.usbr.gov/mp/cvo/vungvari/gdwodop.pdf)
Tuolumne River below LaGrange Dam	USGS, station 11289650 (http://waterdata.usgs.gov/ca/nwis/dv?format=pre&period=31&site_no=11289650)
Merced River at Cressey	CDEC, station CRS (http://cdec.water.ca.gov/cgi-progs/queryF?s=crs)
Merced River near Stevinson	CDEC, station MST (http://cdec.water.ca.gov/cgi-progs/queryF?s=mst)
San Joaquin River at Newman	USGS, station 11274000 (http://waterdata.usgs.gov/ca/nwis/dv?format=pre&period=31&site_no=11274000)

TABLE 2-6
Summary of Daily Operation Plans Prepared During Implementation Phase

VAMP Forecast Date	VAMP Target Flow Period	Assumed Ungaged Flow at Vernalis (cfs)	Existing Flow (cfs)	VAMP Target Flow (cfs)	Supplemental Water needed to meet Target Flow (1,000 AF)
April 22	April 15 - May 15	300	2,331	3,200	53.43
April 30	April 15 - May 15	300	2,322	3,200	53.98

FIGURE 2-1

2003 VAMP—San Joaquin River near Vernalis with and without VAMP.

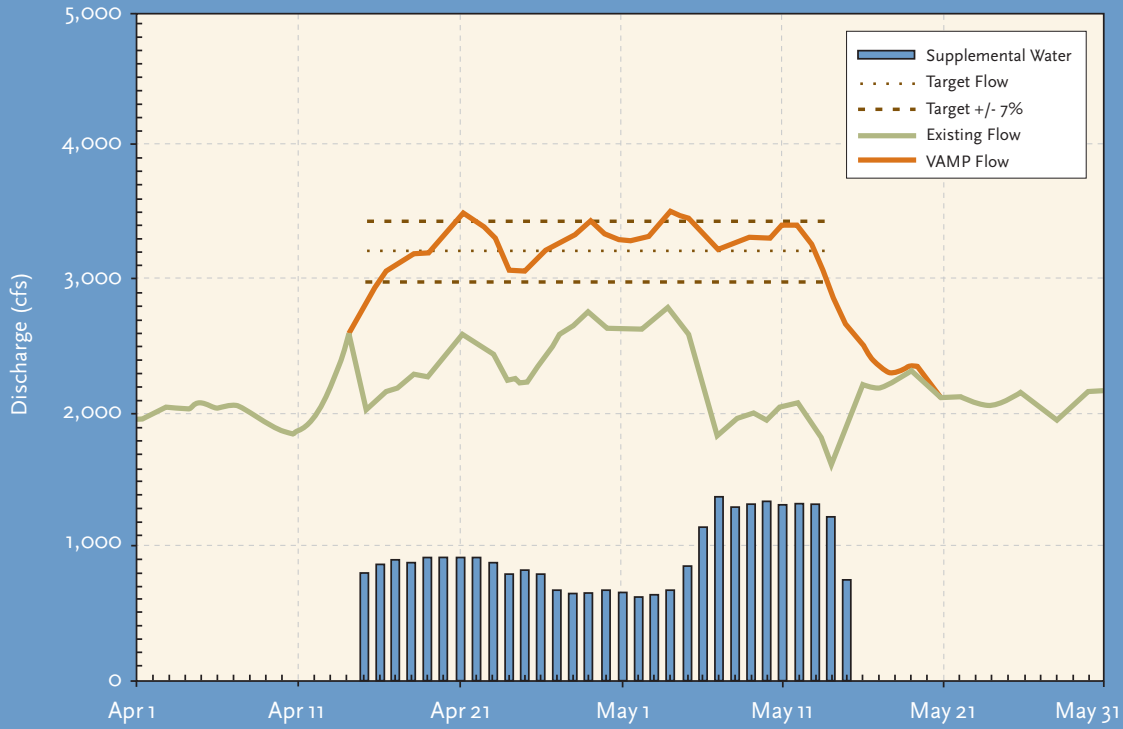
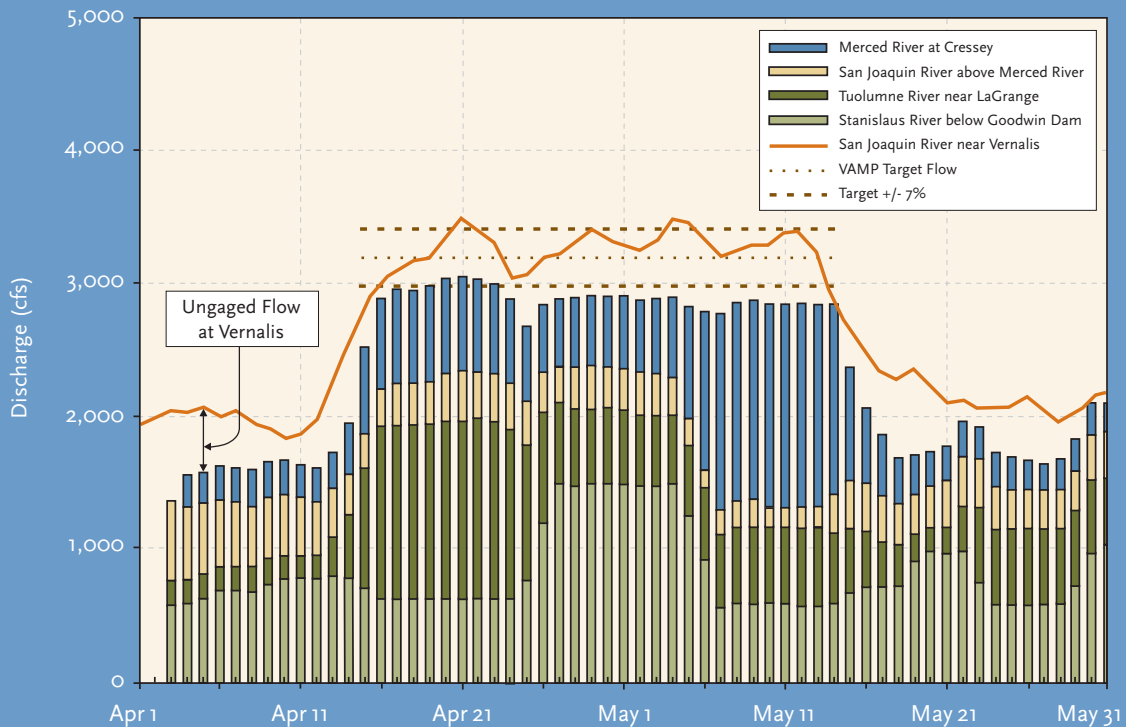

FIGURE 2-2

2003 VAMP—San Joaquin River near Vernalis with lagged contributions from primary sources.



RESULTS OF OPERATIONS

The final accounting for the VAMP operation was accomplished using provisional mean daily flow data available from USGS and DWR as of the end of July.¹ Provisional data has been reviewed and adjusted for rating shifts but is still considered preliminary and subject to change. Plots of the real-time and provisional flows at the primary measuring points are provided in Appendix A to illustrate the differences between the real-time and the provisional data.

The mean daily flow at the Vernalis gage averaged 3,235 cfs during the April 15 – May 15 VAMP test flow period, with a maximum of 3,500 cfs and a minimum of 2,650 cfs. The average flow for the test flow period absent the VAMP supplemental water (existing flow) was estimated to be 2,290 cfs. The VAMP operation resulted in a 41 percent increase in flow at Vernalis during the target flow period. Figure 2-1 shows the flow at Vernalis with and without the VAMP pulse flow. Figure 2-2 shows the sources of the flow at Vernalis. A total of 58,065 acre-feet of supplemental water was provided during the VAMP test flow period.

In planning for the VAMP operation the ungaged flow in the San Joaquin River at Vernalis is the most difficult factor to forecast for the test flow period. The Daily Operation Plan is developed assuming a steady ungaged flow during the test flow period, but in reality there will be day to day fluctuations due to a number of unpredictable factors including weather, pre-existing conditions, irrigation operations, as well as mathematical uncertainties introduced by using mean daily flows and assumed travel times rounded to the nearest day. During the implementation phase of the VAMP operation, the forecasted ungaged flow were not necessarily adjusted as a result of the day to day fluctuations, but were adjusted if the general trend appeared to be deviating from the existing forecast. This is best illustrated in Figure 2-3, which shows in hindsight the observed ungaged flow along with that forecast prior to the test flow period on April 4 and the adjusted forecast that was modified on an ongoing basis in an attempt to account for deviation from the existing forecast.

Another unknown in the forecast equation similar to the ungaged flow is the flow in the San Joaquin River upstream of the Merced River. This unknown tends not to be as variable as the ungaged flow, but, like the ungaged flow, may be adjusted if the observed flow warrants it. Figure 2-4 shows the observed upper

¹ The SJRA Division Agreement Technical Appendix specifies that "By July 31st of each year, each SJTA participant shall provide the records necessary to calculate the flow contribution by each entity to the San Joaquin River Group co-coordinator."

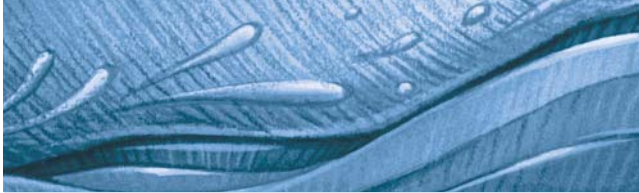

In planning for the VAMP operation the ungaged flow in the San Joaquin River at Vernalis is the most difficult factor to forecast for the test flow period. The Daily Operation Plan is developed assuming a steady ungaged flow during the test flow period, but in reality there will be day to day fluctuations due to a number of unpredictable factors including weather, pre-existing conditions, irrigation operations, as well as mathematical uncertainties introduced by using mean daily flows and assumed travel times rounded to the nearest day.

San Joaquin River flow along with the forecasts made just prior to the test flow period and during the VAMP implementation.

The target combined CVP and SWP export rate for the 2003 VAMP was 1,500 cfs. The observed export rate averaged 1,446 cfs during the 31-day period, about 4 percent below the 1,500 cfs target. The daily SWP and CVP exports during the VAMP test period are shown in Figure 2-5.

SJRG member agencies have entered into the Division Agreement, which allocates responsibility of the member agencies for providing VAMP supplemental water. The member agencies may also enter into additional agreements among themselves regarding delivery of the supplemental water. For the 2003 VAMP Merced I.D and the Exchange Contractors entered into an agreement whereby the Exchange Contractors supplemental water would be provided by Merced I.D. The distribution of supplemental water for the 2003 VAMP operation, compared to the distribution called for under the Division Agreement, is summarized in Table 2-7.

FIGURE 2-3

2003 VAMP—Ungaged flow in San Joaquin River near Vernalis.
Comparison of forecast and observed.

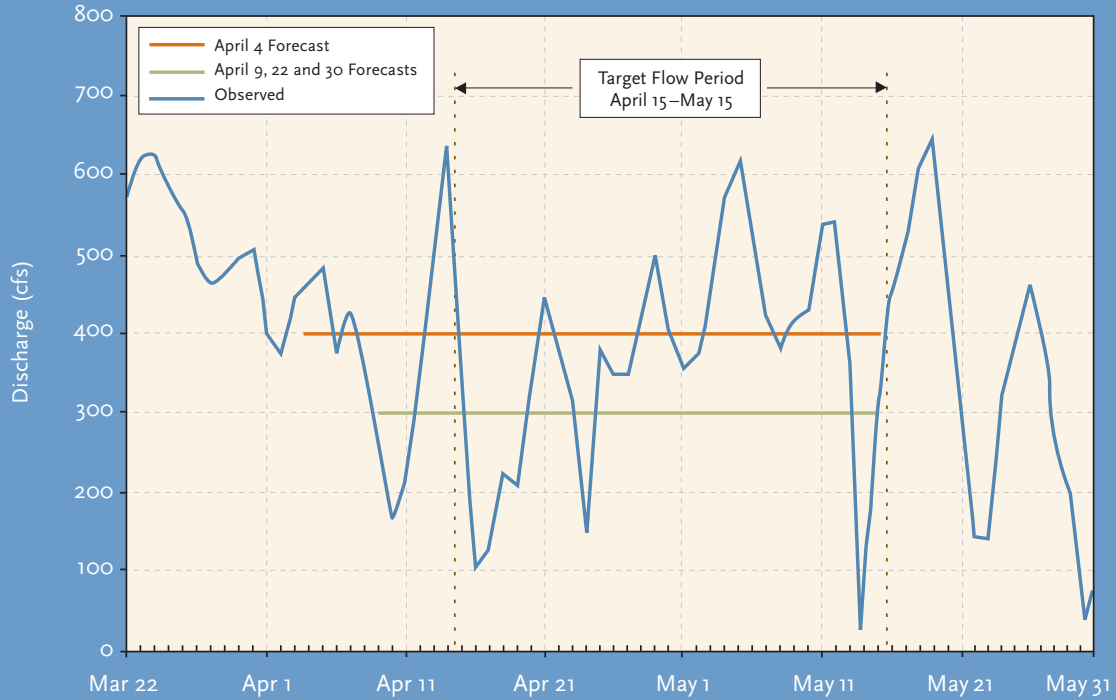
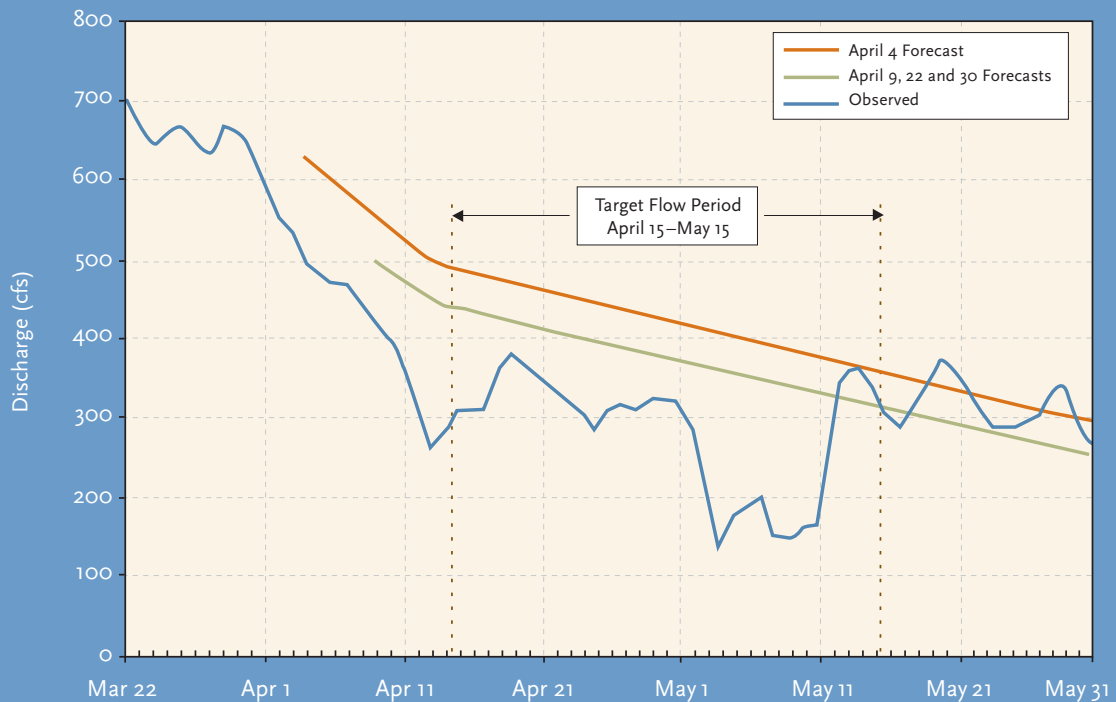

FIGURE 2-4

2003 VAMP—San Joaquin River above Merced River.
Comparison of forecast and observed.



Hydrologic Impacts

The VAMP supplemental water contributions, with the exception of that provided by the Exchange Contractors and OID/SSJID, are supplied from reservoir storage: Lake McClure on the Merced River and New Don Pedro Reservoir on the Tuolumne River. Due to the extended nature of the VAMP, a 12-year plan, the storage impacts can potentially carry over from year to year. Reservoir storage impacts are reduced or eliminated when the reservoirs make flood control releases.

As noted in the 2002 Annual Technical Report, the storage impact in Lake McClure on the Merced River following the April 15 to May 15, 2002 VAMP operation was 95,262 acre-feet. As per the SJRA, Merced provided 12,470 acre-feet of supplemental water in the Fall of 2002 (see Chapter 3), resulting in a total SJRA storage impact on Lake McClure as of October 31, 2002 of 107,732 acre-feet. There were no opportunities to make up for any of this impact during the winter, therefore the entire impact of 107,732 acre-feet carried over into the 2003 VAMP

TABLE 2-7
Distribution of Supplemental Water

Agency	Division Agreement Distribution (acre-feet)	Supplemental Water Provided (acre-feet)	Deviation from Division Agreement (acre-feet)
Merced I.D.	33,065	33,257	+ 192
Oakdale I.D./South San Joaquin I.D.	10,000	10,078	+ 78
Exchange Contractors	5,000	5,000 ^a	0
Modesto I.D./Turlock I.D.	10,000	9,729	- 271

^aThe Exchange Contractors supplemental water was provided by Merced I.D.

FIGURE 2-5

2003 VAMP—Federal and State Exports. (Source: USBR Delta Operations Report)

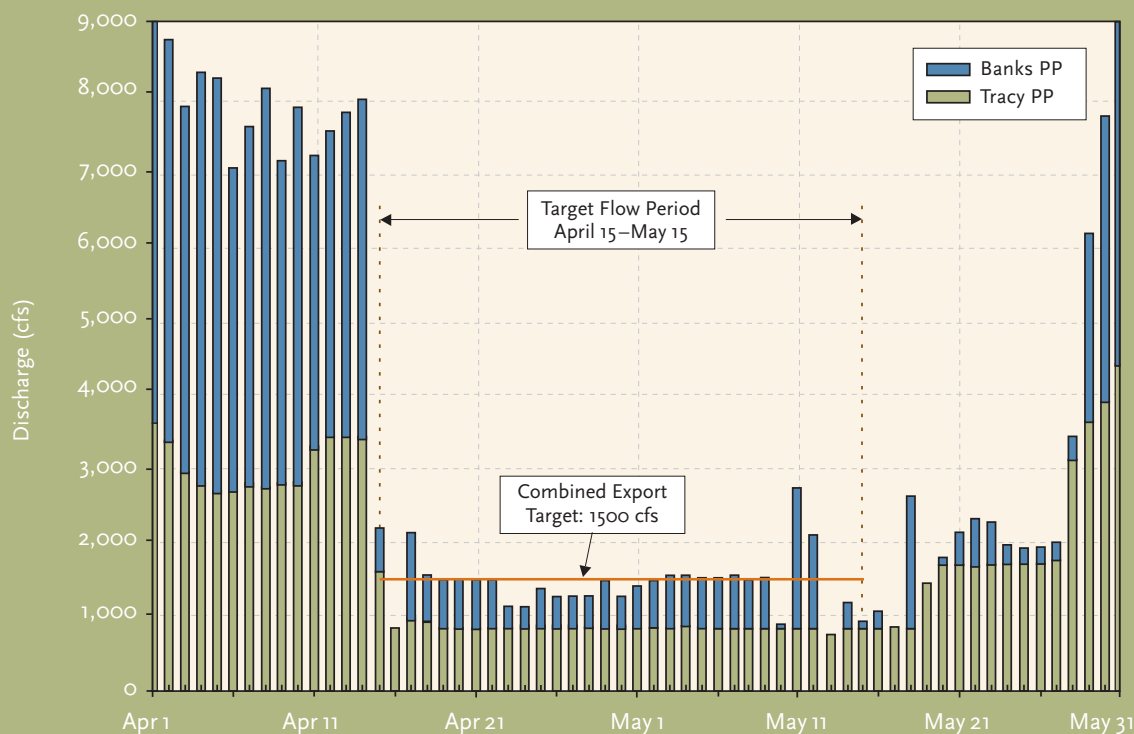

FIGURE 2-6

SJRA storage impacts—Lake McClure (Merced River).
October 2002 through November 2003.

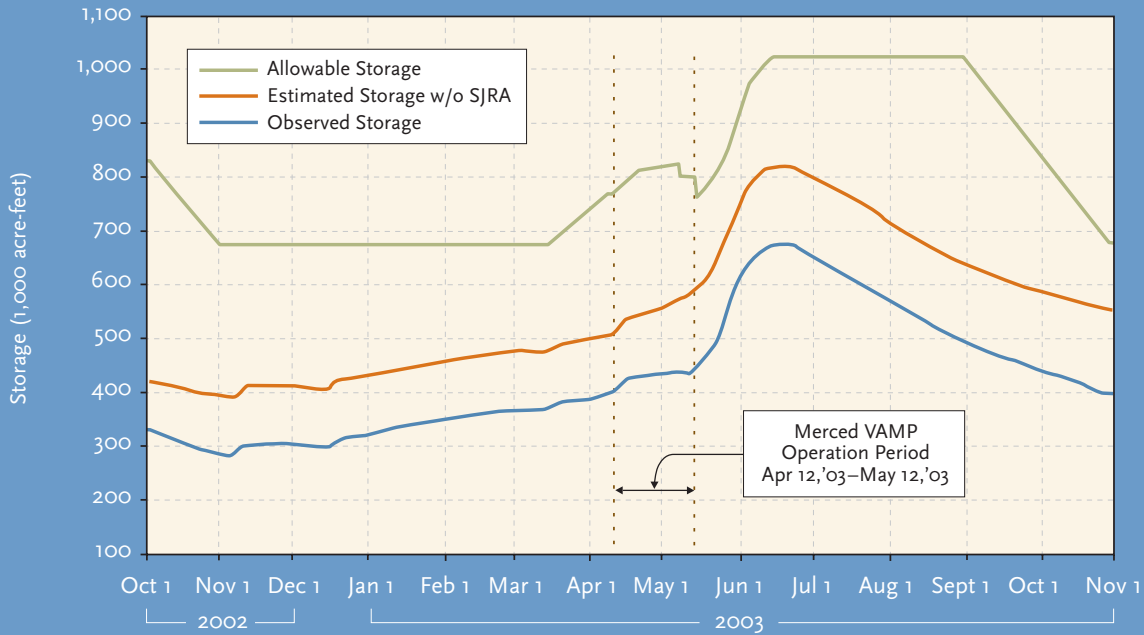

FIGURE 2-7

SJRA storage impacts—New Don Pedro Reservoir (Tuolumne River).
October 2002 through November 2003.

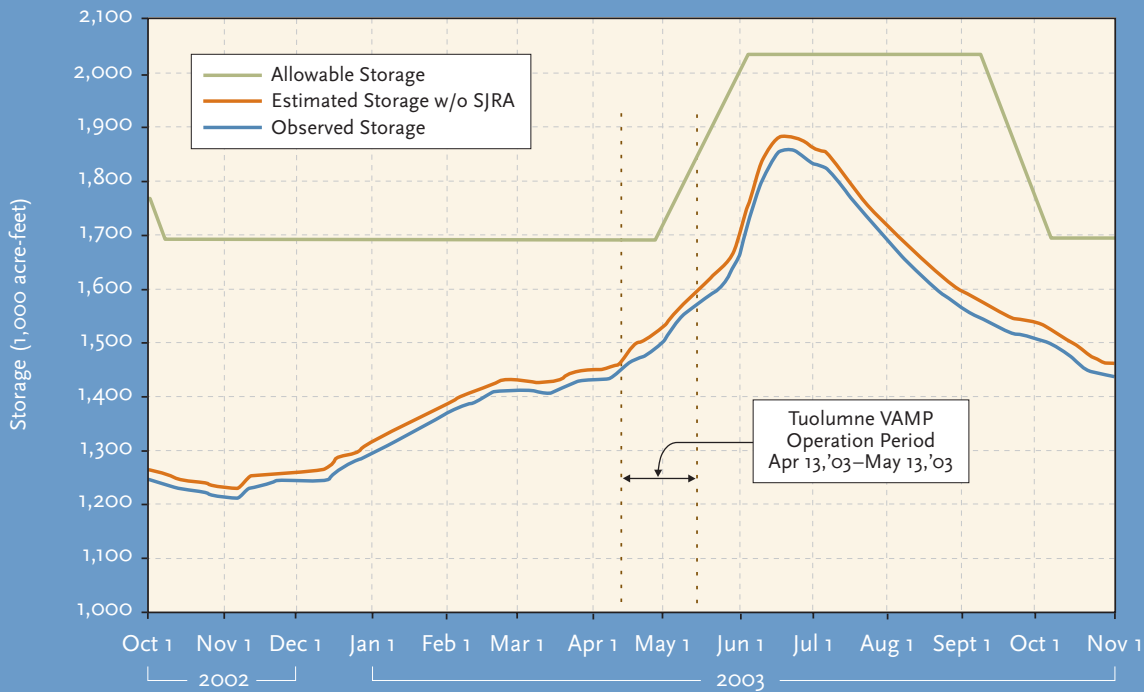

TABLE 2-8
Storage Impact History, Lake McClure (Merced River)

Year	VAMP Supplemental Water (acre-feet) ^a	Fall Supplemental Water (acre-feet)	SJRA Storage Impact Replenishment (acre-feet)	Cumulative Storage Impact (acre-feet)
1998	0	0	0	0
1999	85,339	11,998	48,025 (Jun. – Sep. 1999) 49,312 (Jan. – Feb. 2000)	0
2000	46,750	12,500	46,750 (May 2000)	-12,500
2001	43,146	12,496	0	-68,142
2002	27,120	12,470	0	-107,732
2003	39,586	12,500 ^b		-147,318 ^c

^aIncludes ramping flows ^bScheduled as of Sep.30, 2003 ^cAs of Sep. 30, 2003

TABLE 2-9
Storage Impact History, New Don Pedro Reservoir (Tuolumne River)

Year	VAMP Supplemental Water (acre-feet)	SJRA Storage Impact Replenishment (acre-feet)	Cumulative Storage Impact (acre-feet)
1998	0	0	0
1999	54,268	54,268 (Feb. 2000)	0
2000	22,651	14,955 (Sep. – Oct. 2000) 7,696 (Jan. – Feb. 2001)	0
2001	14,061	0	-14,061
2002	0	0	-14,061
2003	9,729		-23,790 ^a

^aAs of Sep. 30, 2003

operation period. With the 38,257 acre-feet of supplemental water provided by Merced for the 2003 VAMP operation along with 1,329 acre-feet of operational ramp-up and ramp-down water, the current impact of the SJRA on Lake McClure storage as of May 15, 2003 was 147,318 acre-feet (Table 2-8). Figure 2-6 shows Lake McClure storage for water year 2003 with and without the SJRA.

As noted in the 2002 Annual Technical Report, the storage impact in New Don Pedro Reservoir on the Tuolumne River following the 2002 VAMP operation was 14,061 acre-feet. There were no opportunities to make up for any of this impact during the winter, therefore the entire impact of 14,061 acre-feet carried

over into the 2003 VAMP operation period. With the 9,729 acre-feet of supplemental water provided by Modesto I.D. and Turlock I.D. for the 2003 VAMP operation, the current impact of the SJRA on the New Don Pedro Reservoir storage is 23,790 acre-feet (Table 2-9). Figure 2-7 shows New Don Pedro Reservoir storage for water year 2003 with and without the SJRA.

The supplemental water provided by OID/SSJID is made available from their diversion entitlements; therefore there are no storage impacts in New Melones Reservoir on the Stanislaus River due to the SJRA.

CHAPTER 3

Additional Water Supply Arrangements & Deliveries

The SJRA includes a provision (Paragraph 8.4) stating that “Merced Irrigation District (Merced) shall provide, and the USBR shall purchase 12,500 acre-feet of water...during October of all years.” The SJRA also states in Paragraph 8.4.4 that “Water purchased pursuant to Paragraph 8.4 may be scheduled for months other than October provided Merced, DFG and USFWS all agree.” Pursuant to Paragraph 8.5 of the SJRA, “Oakdale Irrigation District (OID) shall sell 15,000 acre-feet of water to the USBR in every year of (the) Agreement...In addition to the 15,000 acre-feet, Oakdale will sell the difference between the water made available to VAMP under the SJRGA agreement and 11,000 acre-feet.” This water is referred to as the Difference water. The purpose of additional water supply deliveries in the fall months is to provide instream flows to attract and assist adult salmon during spawning.

MERCED IRRIGATION DISTRICT

The SJRA includes a provision (Paragraph 8.4) stating that “Merced Irrigation District (Merced) shall provide, and the USBR shall purchase 12,500 acre-feet of water...during October of all years.” The SJRA also states in Paragraph 8.4.4 that “Water purchased pursuant to Paragraph 8.4 may be scheduled for months other than October provided Merced, DFG and USFWS all agree.” This water is referred to as the Fall SJRA Transfer Water. The daily schedule for the Fall SJRA Transfer Water is to be developed by Department of Fish and Game (DFG), United States Fish and Wildlife Services (USFWS) and Merced ID.

The schedule for the 2003 Fall SJRA Transfer was finalized on October 1, 2003, with the transfer commencing on October 1, 2003. The schedule is provided in Appendix B, Table B-1. As with the VAMP operation, the final accounting for the Fall Transfer will be done using provisional flow data.

The 2002 Fall SJRA Transfer was in progress at the time of publication of the 2002 Annual Technical Report and therefore only preliminary data was provided in that report. The final data for the 2002 Fall SJRA Transfer are included in Appendix B, Table B-2, of this report.



The schedule for the 2003 Fall SJRA Transfer was finalized on October 1, 2003, with the transfer commencing on October 1, 2003.

OAKDALE IRRIGATION DISTRICT

Pursuant to Paragraph 8.5 of the SJRA, “Oakdale Irrigation District (OID) shall sell 15,000 acre-feet of water to the USBR in every year of (the) Agreement...In addition to the 15,000 acre-feet, Oakdale will sell the difference between the water made available to VAMP under the SJRGA agreement and 11,000 acre-feet.” This water is referred to as the Difference water.

OID provided 5,039 acre-feet of supplemental water for the 2003 VAMP operation, resulting in 5,961 acre-feet of Difference water (11,000 minus 5,039). Therefore, pursuant to Paragraph 8.5 of the Agreement, OID sold a total of 20,961 acre-feet of water (15,000 plus 5,961) to the USBR in 2003.

The USBR released 6,613 acre-feet of the OID additional water in early June 2003 to support Vernalis flow objectives. The remainder of the OID additional water, 14,348 acre-feet, was released between October 19, 2003 and October 29, 2003, as shown in Table 3-1.

TABLE 3-1
USBR Release of Oakdale Irrigation District SJRA Additional Water
(not including 6,613 acre-feet released in June 2003).

Date	Base Flow (cfs)	Total River Flow (cfs)	Supplemental Water (cfs)	Cumulative Supplemental Water (acre-ft)
19 Oct 03	200	227	27	54
20 Oct 03	200	917	717	1,476
21 Oct 03	200	977	777	3,017
22 Oct 03	200	979	779	4,562
23 Oct 03	200	977	777	6,103
24 Oct 03	200	976	776	7,642
25 Oct 03	200	976	776	9,181
26 Oct 03	200	979	779	10,727
27 Oct 03	200	976	776	12,266
28 Oct 03	200	976	776	13,805
29 Oct 03	200	876	676	15,146 ^a

^a14,348 acre-feet of Oakdale I.D. SJRA Additional Water was released in this period. Supplemental water in excess of this is non-SJRA water.



CHAPTER 4

Head of Old River Barrier

A key component to the VAMP design is the operation of a fish barrier at the Head of Old River. The purpose of the barrier is to prevent migrating salmon smolts from entering Old River. The Old River leads to the SWP/CVP export pumps. A study conducted by the California Department of Fish and Game investigates the entrainment of salmon smolt as part of the Old River barrier evaluation. Monitoring is performed to document juvenile Chinook salmon entrainment through the operable culverts of the HORB.

BARRIER DESIGN, INSTALLATION AND OPERATION

In early April 2003, DWR installed and operated the temporary Head of Old River Barrier (HORB). The spring HORB is a component of the south Delta Temporary Barriers Project (TBP). The TBP mitigates for low water levels in the south Delta and improves water circulation and quality for agricultural purposes. The HORB, as currently configured, is fully permitted though 2005, but must get annual landowner access approval.

The spring HORB was first constructed in 1992. Since then, the barrier has been installed in 1994, 1996, 1997 (w/two

culverts), and 2000—2003 (six culverts). The HORB was not installed in 1993, 1995 and 1998 due to high San Joaquin River flows. The HORB was not installed in 1999 due to landowner access problems. The HORB, a key component of VAMP, is intended to increase San Joaquin River Chinook salmon smolt survival by preventing them from entering Old River.

The HORB was originally designed to withstand a San Joaquin River flow of about 3,000 cfs. Through the years, the design and installation of the HORB has been revised on several occasions to accommodate different needs. Beginning in 2001, the barrier design included two versions. A “low-flow” barrier, when San Joaquin River target flows are below 7,000 cfs would be built to a height of 10 feet mean sea level (MSL). A “high-flow” barrier, for target flow of 7,000 cfs, would be built to a height of 11 feet MSL and additional material would be placed to raise the abutments to 13 feet MSL. Both barrier versions are equipped with six 48-inch diameter operable culverts and an overflow weir back-filled with clay. In 2003, the low-flow version of the HORB was installed.

FIGURE 4-1
Head of Old River Barrier (HORB)

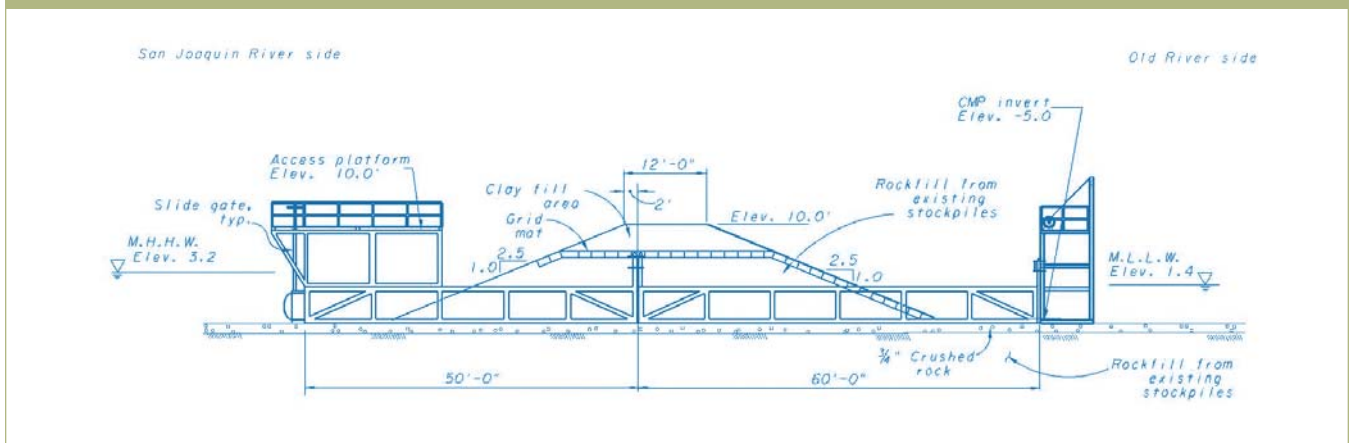

The dimensions of the 2003 HORB (Figure 4-1) were similar to the 2000, 2001 and 2002 HORB. The base width of the HORB in 2003 was 100 feet and the crest elevation was 10 feet MSL. The top of HORB was constructed with a 75-foot wide notch, protected with concrete grid mats and back-filled with clay. The HORB was designed to safely operate with flows corresponding to stages up to 8.5 feet MSL.

To help mitigate anticipated low water levels in the south Delta (downstream of the HORB) caused by the operation of the HORB, two open culverts were installed in the barrier in 1997, and six operable culverts were installed beginning in 2000. Operation of the culverts is controlled by a slide gate control structure located on the upstream side of HORB. DWR relied on daily modeling and field data collection to monitor water levels at three locations within the south Delta to determine when and how long to operate the culverts. Generally, the model would forecast lower low-low water levels lower than actual levels observed in the field. Consequently, DWR would make decisions regarding the culvert operations that would take this into consideration.

The downstream outlet of each culvert was designed so fyke nets could be attached to evaluate fish entrainment. DFG staff conducted a fishery-monitoring program as part of the 2003 HORB operations.

Permitting and Construction

The various permit conditions that are placed on the Temporary Barriers Program, by the USFWS, National Marine Fisheries Service (NOAA Fisheries), and DFG, require that the spring in-water construction activities begin no earlier than April 7 on the Head of Old River (HOR), Middle River (MR), and Old River at Tracy (ORT) barriers. In addition, construction of the northern abutment and boat ramps of the Grant Line Canal (GLC) barrier and construction of out-of-water portions of the HORB, MR, and ORT barriers may not be started any earlier than April 1. Full closure of the GLC barrier is not required but construction of the north abutment and boat ramps must be completed to the extent that full barrier closure and operation can be readily achieved in a reasonable time frame, if and when directed by DWR. The permit conditions also require that all the above work be completed by April 15th, a total of 15 working days. The various permit conditions are as follows:

A key component to the VAMP design is the operation of a fish barrier at the Head of Old River. The purpose of the barrier is to prevent migrating salmon smolts from entering Old River.

USFWS Biological Opinion

- 1) The spring HORB barrier installation may begin on April 1 but in-water work shall not occur until April 7, except for construction necessary to place the scour pad and the pad for the culverts;
- 2) DWR may begin construction of the Middle River barrier on April 1 but in-water work shall not occur until after April 7;
- 3) DWR may begin construction of the Old River at Tracy barrier on April 1 but in-water work shall not commence before April 7;
- 4) DWR may begin construction of the northern abutment and the boat ramp of the GLC barrier on April 1 provided that the HORB barrier is being constructed concurrently.

NOAA Fisheries Biological Opinion

- 1) The spring HORB installation shall begin on April 1;
- 2) The Middle River barrier construction may begin on April 7;
- 3) The Old River at Tracy barrier construction may begin on April 1;
- 4) The northern abutment and boat ramp of the GLC barrier may begin construction on April 1 provided that the HORB is being constructed concurrently.

DFG 1601—HORB

- 1) HORB Spring Installation—All work in or near the stream zone will be confined to the period beginning no earlier than April.
- 2) DFG 1601—Agricultural Barriers
 - MR**—All work in or near the stream zone will be confined to the period beginning no earlier than March 1.
 - ORT**—All work in or near the stream zone will be confined to the period beginning no earlier than April 1.
 - GLC**—All work in or near the stream zone will be confined to the period beginning no earlier than April 1.

In addition to the above conditions, water users of the South Delta Water Agency (SDWA) and the fisheries agencies impose separate mitigation requirements on DWR for installation and operation of the HORB by itself. As a result, DWR's contractor must sequentially close and start operation of the MR and ORT barriers, and complete as much construction of north abutment and boat ramps on the GLC barrier as possible, before they can close and operate the HORB.

From the contractors point of view there are really two milestones that must be completed in sequence. First and foremost is to obtain closure and operation of the barriers in accordance with the conditions imposed by the project permits/biological opinions and mitigation requirements. The second is to satisfy DWR's contract specifications. The first milestone can be achieved within the required 15 working days but it is unlikely that the contractor can complete the entire amount of work required to satisfy DWR's contract specifications within the same time period. Therefore, the contractor's construction activities consist of placing enough materials to make sure they obtain closure and operation by April 15th, then following closure they continue placing barrier material above the water line until barrier construction is completed in accordance with DWR's contract specifications. The contractor then conducts site cleanup and demobilizes from the site. This is why work usually continues beyond the April 15 deadline.

The current permits allow for in-water work to begin April 1 with barrier closure no earlier than April 15th. Once the HORB is closed, typically on April 15, construction crews remain on site to install a clay plug, lay down concrete mats, put up fencing and lighting and perform general site clean-up. Post barrier closure work can take up to a week to complete.

The Department of Fish and Game (DFG), who monitors fish entrainment through the barrier culverts, does not begin sampling efforts (for safety reasons) until the crews have finished their work and moved heavy equipment out of the area. A delay in beginning sampling at the barrier, in turn, delays VAMP releases of salmon smolts. Knowing how many smolts are entrained at the barrier is important in interpreting the survival data from VAMP tagged salmon. VAMP usually conducts two sets of releases. Optimally, salmon releases would occur a week apart to measure survival under replicate conditions. Delaying releases can result in increased river temperatures for the latter replicate, making it difficult to have similar water temperature conditions for the two sets of releases.

Numerous discussions with DWR, NOAA Fisheries, USFWS, and DFG biologists explored every aspect of HORB installation, timing, and fishery concerns. Construction and complete closure of HORB takes two weeks, not including site clean-up. Concurrent installation of Old River at Tracy, Middle River and Grant Line Canal barriers requires substantial effort because the Middle River and Old River at Tracy barriers must be available along with the HORB to protect water levels downstream.

In February of 2003, the VAMP technical committee wanted to explore the possibility of changing the Head of Old river Barrier operating permits to allow flexibility on a year-to-year basis to install and operate the barrier prior to April 15th. At this time, changing the permits to allow for early construction of the HORB is not feasible. The following are constraints to closure and operating the HORB prior to April 15th:

- (1) The DFG and USFWS will not allow in-water work to begin any earlier than April 1 due to Delta smelt concerns. When the HORB is closed and the State Water Project and Central Valley Project are pumping at rates higher than the San Joaquin River flows, reverse flows occur in the central Delta. During reverse flows, Delta smelt that have migrated upriver may have increased vulnerability to entrainment in the south Delta. Conditions may be better for Delta smelt that spawn in early spring when barrier closure is delayed.
- (2) With an experienced construction crew, the HORB takes two weeks to close. If the culverts were to be semi-permanently installed, the barrier could be constructed in approximately a week. The current HORB permits allow for the culverts to be semi-permanently installed, however, there are difficulties in accomplishing this. Entry permits for the south side of the river are difficult to obtain and are granted for a limited period of time each year, and the culverts would partially protrude into the river. DWR would have to cut into the bank and dredge the river and mitigation would be costly.
- (3) If the HORB were to be installed early, the three agricultural barriers would also have to be installed early. The South Delta Water Agency would have to be involved to renegotiate the terms of barrier operations on a yearly basis.

Optimally, salmon releases would occur a week apart to measure survival under replicate conditions. Delaying releases can result in increased river temperatures for the latter replicate, making it difficult to have similar water temperature conditions for the two sets of releases.

Barrier Operations and Monitoring Plan

A barrier operations and monitoring plan was developed based on forecasting and monitoring of tidal conditions. DWR determined the number of culverts to be opened at the HORB so that water levels at Old River near Tracy Road Bridge and Grant Line above Doughty Cut would remain above 0.0 feet MSL and Middle River near Howard Road above 0.3 feet MSL. Based on modeling results and field monitoring of water levels in the south delta, three of the six culvert slide gates remained open during the VAMP target flow period.

Flow Measurement At and Around Barrier

This year DWR installed a Doppler “Argonaut” flow measuring device inside culvert #4. Data was recorded every 15 minutes during the period when the HORB was in operation. Table 4-1 displays the daily average, maximum and minimum flows measured in culvert #4. The mean daily flow through the culverts varied in response to tidal and San Joaquin River flow conditions. The characteristics of the flow through the culverts are complicated in that the flow rate is influenced by many variables, including the culvert inlet geometry, slope, size, culvert roughness, and approach and tail water conditions. Since the culverts are similar in configuration and size, the total flow through the three culverts can be estimated by using three times the measured flow through culvert #4. Under this assumption the mean daily flow through the culverts during the target flow period ranged from 139 cfs to 198 cfs, with an average of 171 cfs.

In addition to the Doppler “Argonaut” in culvert #4, a fixed Acoustic Doppler Current Meter was operated approximately 840 feet downstream of the HORB. The Acoustic Doppler Current Meter records velocity measurements every 15 minutes, from

Date	Flow (cfs)		
	Average	Minimum	Maximum
4/14/03	46	32	63
4/15/03	51	33	69
4/16/03	62	13	81
4/17/03	66	47	85
4/18/03	65	44	81
4/19/03	64	45	83
4/20/03	62	42	81
4/21/03	58	11	79
4/22/03	60	13	83
4/23/03	60	13	79
4/24/03	56	12	78
4/25/03	59	20	75
4/26/03	59	12	76
4/27/03	59	10	77
4/28/03	55	12	72
4/29/03	57	12	73
4/30/03	58	11	74
5/1/03	56	11	75
5/2/03	56	8	76
5/3/03	54	14	72
5/4/03	56	9	77
5/5/03	59	13	77
5/6/03	56	12	78
5/7/03	53	8	73
5/8/03	52	12	72
5/9/03	57	15	78
5/10/03	57	10	75
5/11/03	57	12	77
5/12/03	57	7	77
5/13/03	57	7	73
5/14/03	54	37	71
5/15/03	53	37	68
5/16/03	51	32	68

TABLE 4-2
Flow in San Joaquin River and Old River Downstream of the HORB – 2003 (values in CFS)

Date	San Joaquin River near Vernalis (1)	Old River at Head (2)	San Joaquin River below Old River (3)	Through HORB Culverts (4)	Estimated HORB Seepage (5)	Date	San Joaquin River near Vernalis (1)	Old River at Head (2)	San Joaquin River below Old River (3)	Through HORB Culverts (4)	Estimated HORB Seepage (5)
4/01/03	1,950	1,017	933			5/01/03	3,280	258	3,022	168	90
4/02/03	2,010	820	1,190			5/02/03	3,260	189	3,071	168	21
4/03/03	2,050	846	1,204			5/03/03	3,330	192	3,138	162	30
4/04/03	2,030	838	1,192			5/04/03	3,489	326	3,163	168	158
4/05/03	2,080	862	1,218			5/05/03	3,459	341	3,118	177	164
4/06/03	2,010	832	1,178			5/06/03	3,320	354	2,966	168	186
4/07/03	2,050	709	1,341			5/07/03	3,210	325	2,885	159	166
4/08/03	1,970	649	1,321			5/08/03	3,240	388	2,852	156	232
4/09/03	1,920	507	1,413			5/09/03	3,290	360	2,930	171	189
4/10/03	1,850	617	1,233			5/10/03	3,270	334	2,936	171	163
4/11/03	1,880	368	1,512			5/11/03	3,370	305	3,065	171	134
4/12/03	1,970	262	1,708			5/12/03	3,360	316	3,044	171	145
4/13/03	2,260	379	1,881			5/13/03	3,190	359	2,831	171	188
4/14/03	2,600	415	2,185	138	277	5/14/03	2,829	434	2,395	162	272
4/15/03	2,839	354	2,485	153	201	5/15/03	2,600	389	2,211	159	230
4/16/03	3,000	388	2,612	186	202	5/16/03	2,430	372	2,058	153	219
4/17/03	3,090	467	2,623	198	269	5/17/03	2,270	385	1,885		
4/18/03	3,160	427	2,733	195	232	5/18/03	2,210	373	1,837		
4/19/03	3,180	469	2,711	192	277	5/19/03	2,290	661	1,629		
4/20/03	3,350	459	2,891	186	273	5/20/03	2,160	462	1,698		
4/21/03	3,469	409	3,060	174	235	5/21/03	2,020	432	1,588		
4/22/03	3,390	280	3,110	180	100	5/22/03	2,010	500	1,510		
4/23/03	3,300	291	3,009	180	111	5/23/03	1,960	603	1,357		
4/24/03	3,050	207	2,843	168	39	5/24/03	1,940	721	1,219		
4/25/03	3,070	179	2,891	177	2	5/25/03	1,950	756	1,194		
4/26/03	3,200	270	2,930	177	93	5/26/03	2,020	675	1,345		
4/27/03	3,240	284	2,956	177	107	5/27/03	1,900	613	1,287		
4/28/03	3,320	218	3,102	165	53	5/28/03	1,810	663	1,147		
4/29/03	3,420	285	3,135	171	114	5/29/03	1,890	822	1,068		
4/30/03	3,320	322	2,998	174	148	5/30/03	2,000	945	1,055		
						5/31/03	2,020	906	1,114		

VAMP target flow period highlighted

- (1) USGS provisional data as of 11/6/2003
- (2) DWR Acoustic Doppler Current Meter located 840 ft. downstream of HORB
- (3) (1) – (2)
- (4) Three times the measured flow in HORB Culvert #4.
- (5) (2) – (4)

which the flow is calculated using the known cross-sectional area of the channel as a function of the stage elevation at that location. The mean daily flow measured in Old River during the target flow period ranged from 179 to 469 cubic feet per second as shown in Table 4-2 and Appendix A-4.

Hydraulic modeling of the San Joaquin River between Vernalis and Old River¹ shows that the tidal effects on flow at the Head of Old River are insignificant when mean daily flows are used, and that the mean daily flow in the San Joaquin River near Vernalis is essentially the same as the mean daily flow in the San Joaquin River at Old River. Therefore the mean daily flow in the San Joaquin River downstream of Old River can be estimated as the difference between the mean daily flow near Vernalis and the mean daily flow measured by the Acoustic Doppler in Old River downstream of the HORB. The difference between the Old River flow and the flow through the culverts is representative of the seepage through the HORB. The flows at and around the HORB are summarized in Table 4-2.

The Department also installed a stage monitoring station on the San Joaquin River approximately 1000 feet downstream of the confluence with Old River. At this station, they installed an acoustical fixed Doppler as well as a satellite transmission devices required to post the data on the website. At this time, the Department is in the process of calibrating this station by establishing a stage-flow relationship. The station is expected to be fully operational and transmitting flow data by February 2004. Currently the mean daily flow in the San Joaquin River can be estimated as the mean daily flow at Vernalis minus the mean daily flow measured by the Acoustic Doppler in Old River.

Barrier Emergency Response Plan

In addition to the operations and monitoring plan, DWR has also prepared an “Emergency Operations Plan for the Spring HORB”. The plan provided that if the daily measured or forecasted flow at Vernalis exceeded a flow that would correspond to stage at the HORB of 10.0 feet MSL, and the stage was likely to exceed 11.0 feet MSL (the height of the barrier under the “high-flow” target), the barrier would be removed. Vernalis flows and stages at the barrier were not high enough in 2003 to warrant action under the emergency operations plan.

Levee Seepage Monitoring

A seepage-monitoring program on adjacent lands was initiated in April 2000 and continued this year, to evaluate the effects of HORB operations on seepage and groundwater on Upper Roberts Island.

Three seepage monitoring well sites were chosen in 2000 on Upper Roberts Island. Each site has two shallow wells, positioned 10 feet and 100 feet from the toe of the levee to monitor the seepage gradient to and from the San Joaquin River. In addition, a deeper well was drilled at Site 1 (near the Head of Old River) to determine vertical gradients.

In addition to the groundwater monitoring wells, a temporary gage was installed in April 2000 to record water surface elevations in the San Joaquin River, about 1,500 feet downstream of the HORB. Installation of a permanent tide gage was completed in early 2002. Flow data will be generated as staff resources permit. The water surface elevations in the San Joaquin River are compared to groundwater levels on Upper Roberts Island to determine how groundwater levels change relative to changing water level conditions in the river.

As reported in the 2002 VAMP Technical Report DWR produced a seepage report for the 2001—2002 period. DWR will be releasing the latest annual (2002—2003) report in late 2003 once the current data analysis is completed. Based on the 2000 and 2001 data it is apparent that the San Joaquin River stage influences groundwater levels on Upper Roberts Island. When stage increases in the river, groundwater levels will rise toward the land surface, but not as rapidly as the river stage rises. However, over the monitoring period, river stage did not reach levels sufficient to raise groundwater levels to the point where seepage into crop root zones might occur.

Given the results of the seepage monitoring since April 2000, DWR staff expects that if a VAMP target flow of 7,000 was implemented, stages near the HORB would rise to about 7½ to 8 feet MSL. This would translate to groundwater levels in the monitoring well closest to the levee of about 6½ to 7 feet MSL. Because the ground surface elevation is 13 feet MSL near site 1, DWR concludes that seepage should not impact the root zone of crops that could be planted in this area.

The monitoring program will be continued in order to gather more data, particularly during high flow periods in the spring.

Fishery Monitoring At The Head Of Old River Barrier

During the VAMP 2003 test period, all six culverts in the Head of Old River Barrier (HORB) were installed; however, only three of the culverts were open. The six culverts are installed to maintain water quality and water levels in the south Delta downstream of the HORB. Since the culverts are not screened, juvenile

¹UNET (one-dimensional unsteady flow computer model) analysis of lower San Joaquin River by MBK Engineers.



Chinook salmon and other fish species that pass near the culverts are vulnerable to entrainment. An entrainment monitoring study was designed and implemented by the DFG to evaluate and quantify fish entrainment at the HORB. The specific objectives of the 2003 fishery investigations were:

- Determine the total number of juvenile Chinook salmon and other fish species entrained through the culverts at the HORB (Entrainment Monitoring);
- Determine the percentage of coded-wire tagged (CWT) salmon released at Mossdale and Durham Ferry entrained into Old River (Entrainment Monitoring); and
- Determine tidal and diel effects on juvenile Chinook salmon entrainment (Entrainment Special Study).

Results of these fishery investigations are intended, in part, to provide information on the design and operation of a future permanent operable barrier at the head of Old River.

MATERIALS AND METHODS

As part of the VAMP 2003 studies, approximately 75,000 VAMP CWT salmon were released at Durham Ferry on April 21 and approximately 50,000 CWT salmon were released at Mossdale on April 22. The Mossdale release was split in half with 25,000 CWT salmon released around noon and a second group of 25,000 CWT salmon released at 6 pm. The same size releases were repeated on April 28 and 29 at Durham Ferry and Mossdale, respectively. Salmon from the VAMP releases were used in the Entrainment Monitoring studies. For the Entrainment Special Study, 8 uniquely color-marked groups of juvenile Chinook salmon (approximately 3,000 fish per group) were marked with photonic fluorescent microspheres at the Merced River Hatchery. The salmon were transported to the HORB and placed in live cages where they were held at least 10 hours before release. Each color-marked group was released approximately one mile upstream of the HORB, in the middle of the San Joaquin River. The color-marked releases coincided with the two VAMP salmon releases. On the night of April 22, one group was released on the ebb tide and one group on the flood tide. The following day, a group was released on the subsequent ebb and flood tides. The process was repeated on April 29.

Fish entrained into the culverts were caught with fyke nets. The nets have a 48 inch cylindrical mouth tapering down to a 1-foot square cod-end, are made of 1/4 inch braided mesh, and are 60 feet long. A live-box (15.5 x 19.5 x 36 inches), constructed

of perforated aluminum sheet metal, was attached to the cod-end of each net. Each live-box has an aluminum baffle designed to reduce water velocities within the live-box and improve survival of captured fish. The fyke nets were attached to the culvert flanges on April 17. The culverts were numbered 1 through 6 with number 1 located next to the shoreline and number 6 located mid-channel (Figure 4-2). The nets were attached to culvert number 4, 5 and 6. They were attached to the culverts by closing the culvert slide gates on the upstream side of the barrier, raising the flanges that slide over the culvert outfalls, and then strapping the nets over the flanges. On April 21, the flanges, with the attached fyke nets, were lowered down to the culvert outfalls and the live-boxes were attached to the cod-end of the nets to commence sampling.

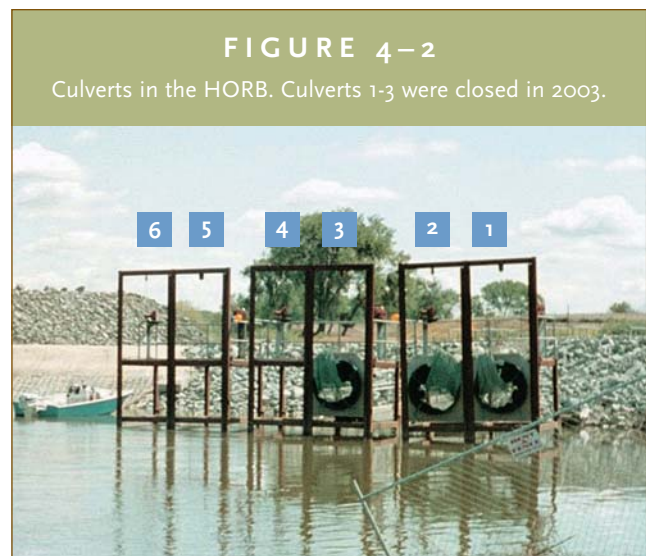

The fyke nets were checked on every tide change until May 10. From May 10 through May 12, the nets were checked at 04:00, 08:00, 18:00 and 22:00 hours. On May 13, the nets were removed. The nets were checked by closing the culvert slide gate for about 30 minutes which enabled the live-boxes to be pulled onto a boat so that the fish could be removed and placed into buckets. Once all the nets had been checked and reset, the collected fish were processed. The fish were speciated and counted. Fork lengths (mm) were recorded for up to 50 salmon per live-box. Salmon were checked for a clipped adipose fin and for the presence of a color mark on the dorsal, anal, or caudal fin. Salmon that had a clipped adipose fin were saved for CWT processing. The color and location of the dyed fin was noted for each color-marked salmon. Culvert number, date, time, water temperature, tidal stage, and diel-period were

FIGURE 4-3

Daily average number of salmon entrained per hour at the HORB in 2003. The total catch is divided into CWT and unmarked salmon.

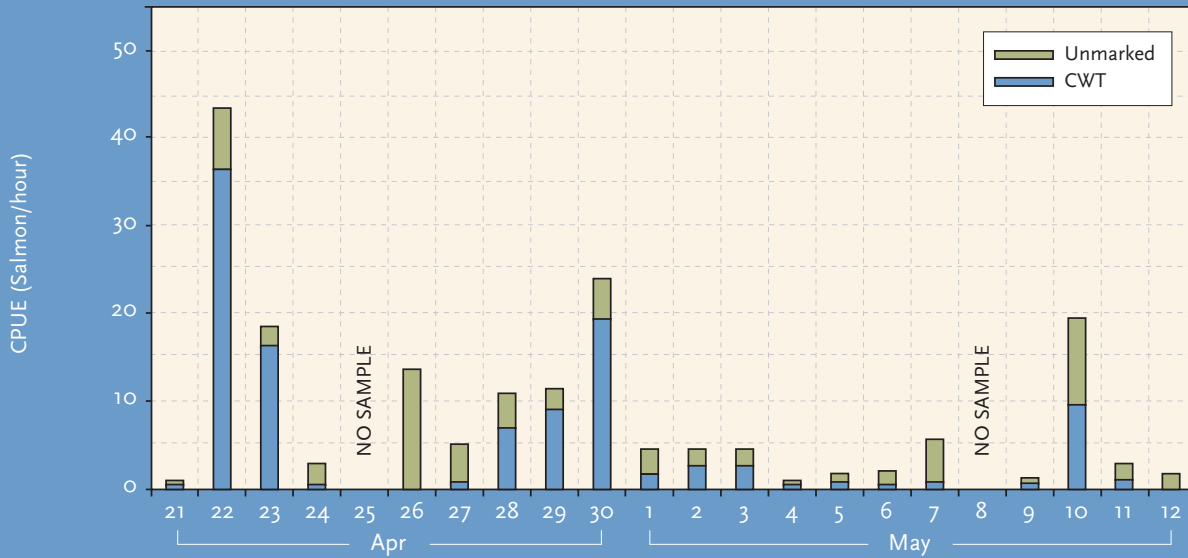
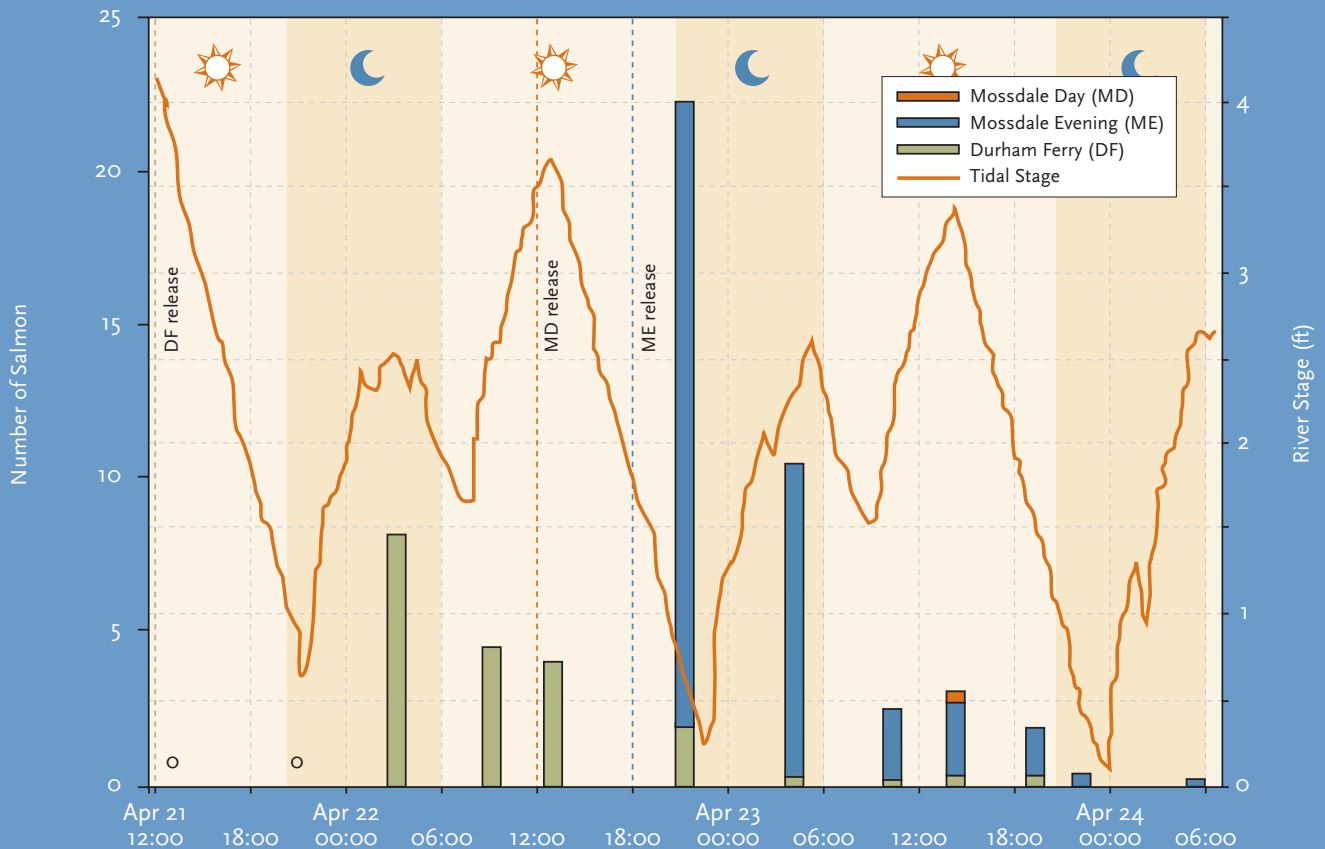

FIGURE 4-4

The average number of salmon per hour entrained at the HORB, by tidal stage, for the first VAMP salmon release. Salmon release times are marked by dashed lines. River stage for Old River is indicated by solid line.



recorded for each net check. Except for the CWT smolts, all processed fish were released downstream of the fyke nets into Old River.

Loss indices for the CWT salmon released as part of the VAMP survival studies at Durham Ferry and Mossdale were calculated based on data collected from April 21 to May 12. The loss index represents the percentage of CWT salmon entrained into the HORB culverts. The loss index (I) is calculated using the equation:

$$I = (TC / TR)$$

Where:

TC = Total number of CWT salmon collected in fyke nets, and

TR = Total number of CWT released

For the two occasions when all three nets were pulled and the culverts were still open, the number of salmon entrained was estimated by averaging the salmon entrainment the day before and after the time period the nets were pulled. Catch-Per-Unit-Effort (CPUE) for salmon was calculated as the number of fish collected per hour. The percentage of color-marked salmon recovered in the fyke nets compared to the total number released was used as an index of entrainment vulnerability at the HORB.

RESULTS

The HORB was closed on April 15; however, construction on the barrier continued for another week. The DFG monitored the HORB culverts for 22 days and collected 246 samples. The nets sampled 1,421 hours out of a possible 1,581 hours. Approximately 7,000 fish were collected representing at least 25 species from 12 families of fish. No delta smelt (*Hypomesus transpacificus*), 2 juvenile steelhead (*Oncorhynchus mykiss*), and 45 adult splittail (*Pogonichthys macrolepidotus*) were collected. The most abundant species was Chinook salmon, followed by white catfish (*Ictalurus catus*) and common carp (*Cyprinus carpio*) (Table 4-3). These 3 fish comprised 90% of the total entrainment. Of the 4,872 salmon caught; 2,511 had a CWT; 1,937 were unmarked; and 424 had a color-mark. Overall, the amount of salmon entrained per hour (3.4) with the 3 culverts was higher than the 6 culverts in 2003 (2.5 salmon/hour) and in 2002 (1.4 salmon/hour).

Salmon smolts were caught throughout the monitoring period (Figure 4-3). Most of the VAMP released salmon were caught within two days of their release. During the first set of VAMP salmon release, CWT salmon entrainment was the highest on the evening of April 22, especially for the Mossdale

TABLE 4-3
The raw abundance and composition of fishes entrained at the HORB in 2003. Chinook salmon catch is divided into CWT salmon, unmarked salmon, and color-marked salmon.

Species	Catch
American Shad	1
Western Mosquitofish	1
Spotted Bass	1
Warmouth Bass	1
Yellowfin Goby	1
<i>Petromyzontidae</i>	2
Golden Shiner	2
Prickly Sculpin	2
Steelhead	2
Black Crappie	4
Tule Perch	4
Largemouth Bass	5
Bigscale Logperch	6
Striped Bass	7
Green Sunfish	9
<i>Ameiurus</i> Spp.	12
Inland Silverside	13
Redear Sunfish	13
Bluegill	37
Splittail	45
Goldfish	58
Sacramento Sucker	65
Channel Catfish	161
Threadfin Shad	273
Common Carp	383
White Catfish	1,170
Total Chinook Salmon	4,872
CWT VAMP Salmon	1,819
CWT NonVAMP Salmon	692
Unmarked Salmon	1,937
Color-Marked Chinook Salmon	308
TOTAL	7,150

evening released fish (Figure 4-4). For the set of second VAMP release, the highest salmon entrainment occurred during the night of April 29 (Figure 4-5). The loss indices for the first Durham Ferry and Mossdale releases were 0.5% and 1.6%, respectively. The loss indices for the second Durham Ferry and Mossdale releases were 0.3% and 0.8%, respectively. Within the Mossdale releases, the highest loss indices were for the releases that occurred in the evening: 3.1% for the first release and 1.5% for the second release. Both of the day releases at Mossdale had a loss index of 0.1%. The overall loss index for VAMP CWT salmon was 0.7%. This year's overall loss index was lower than in 2002 (1.5%) but similar to 2001 (0.5%) and 2000 (0.8%) loss indices.

For the entire monitoring duration, the mean \pm SD CPUE for VAMP salmon per culvert was 1.1 ± 3.3 fish/hour. The highest CPUEs occurred soon after the VAMP releases, with a maximum CPUE of 25.1 fish/hour on April 22. The mean unmarked smolt CPUE (1.2 ± 2.2) was similar to the VAMP CPUE. The highest unmarked CPUE (12.2) occurred April 27. VAMP mean salmon CPUE was similar between the flood (1.3 ± 4.0) and ebb (1.2 ± 3.0) tides, and slightly higher at night (1.2 ± 3.0) than during the day (0.8 ± 3.2). Unmarked mean CPUE was similar between the flood (1.1 ± 2.2) and ebb (1.3 ± 2.2) tides, and higher at night (2.6 ± 2.8) than during the day (0.5 ± 0.4).

To address tidal and diel effects, color-marked smolts were released on various tidal and diel period combinations. The first releases went well; however, like last year, some problems were encountered during the second release when an unknown number of smolts escaped from the holding pens before their intended release. Although some salmon escaped, entrainment rates were higher for the second releases (1.7%) than the first releases (0.8%) (Table 4-4). The overall color-marked salmon entrainment rate was 1.3%. More smolts were caught at night than during the day, and more smolts were entrained during the flood than the ebb tide.

Culvert number 4 entrained about half as many salmon as culvert numbers 5 and 6. (Figure 4-6). This is in contrast to 2002 results in which culvert number 4 entrained the most salmon and culvert number 6 the least. While the mean CPUE for unmarked fish caught at night was about 5 times greater than during the day, the total number of unmarked fish entrained was almost 11 times more during the night than during the day. In contrast to the unmarked salmon, only twice as many CWT salmon and 3.5 times as many color-marked salmon were entrained at night (Table 4-5).

TABLE 4-4
The percentage of color-marked salmon entrained for various diel and tidal stages. Due to some salmon escaping from their live-cages the number of salmon released was estimated for the second releases.

	No. Release	Diel	Tide	Entrained	Percent Recovered
First Releases (22 & 23 April)	3,005	Night	Flood	91	3.0%
	3,008	Night	Ebb	3	0.1%
	2,997	Day	Flood	1	0.0%
	3,014	Day	Ebb	6	0.2%
Total	12,024			101	0.8%
Second Releases (29 & 30 April)	3,000	Night	Flood	80	2.7%
	2,990	Night	Ebb	104	3.5%
	3,000	Day	Flood	18	0.6%
	2,980	Day	Ebb	6	0.2%
Total	11,992			208	1.7%

TABLE 4-5
The total number of CWT and Unmarked salmon caught per culvert by diel period.

		Culvert Number			Total
		4	5	6	
CWT	Day	141	407	313	861
	Night	356	569	801	1,726
Unmarked	Day	22	59	54	135
	Night	261	603	701	1,565
Color-marked	Day	16	32	20	68
	Night	27	101	112	240

No current velocity meter was used this year; however, DWR installed a flowmeter in culvert number 4. Flow data for culvert number 4 was recorded throughout the monitoring period. Simple linear regression analysis indicated CWT salmon showed no significant relationship between CPUE and flow ($df=65$, $P=0.11$, $r^2=0.04$) and unmarked salmon showed a weak positive relationship ($df=65$, $P<0.01$, $r^2=0.10$) (Figure 4-7).

FIGURE 4-5

The average number of salmon per hour entrained at the HORB, by tidal stage, for the second VAMP salmon release. Salmon release times are marked by dashed lines. River stage for Old River is indicated by solid line.

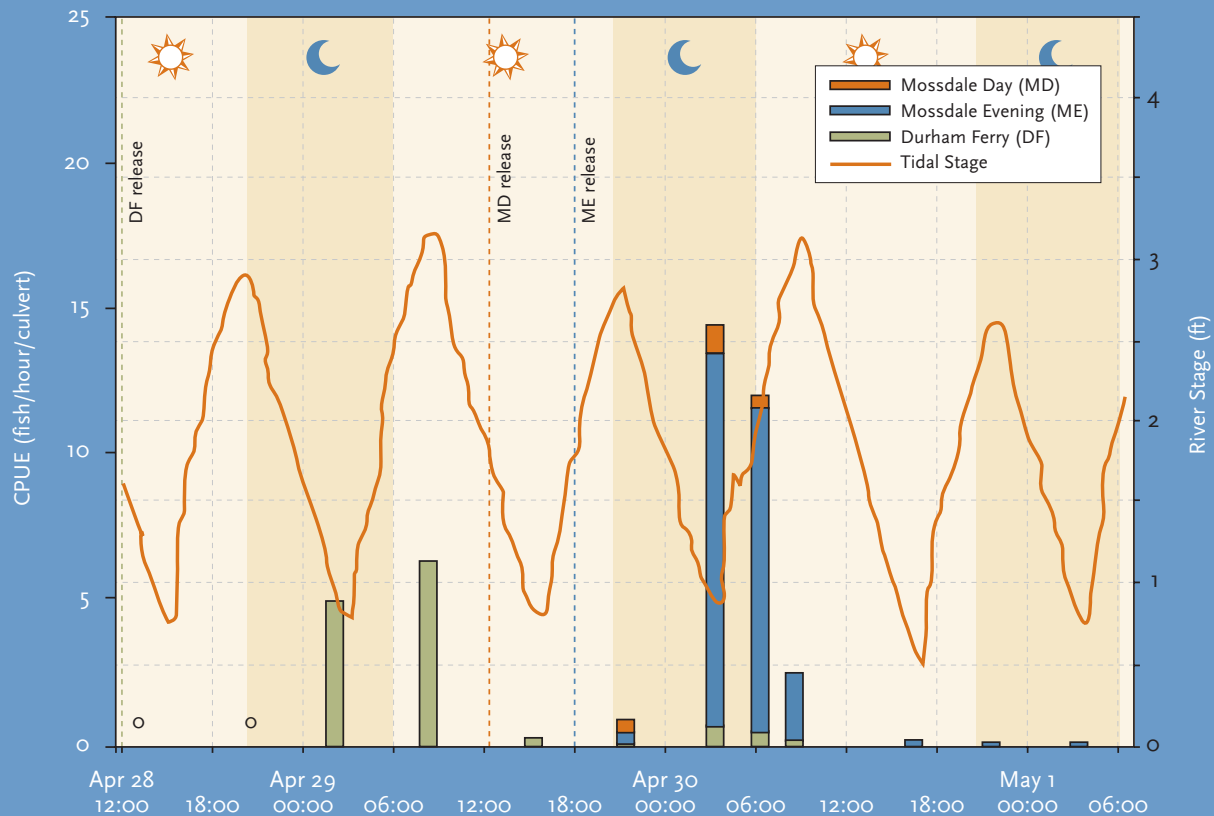

FIGURE 4-6

The total number of unmarked, color marked, and VAMP salmon caught by culvert. Culvert numbers 1-3 were closed in 2003.

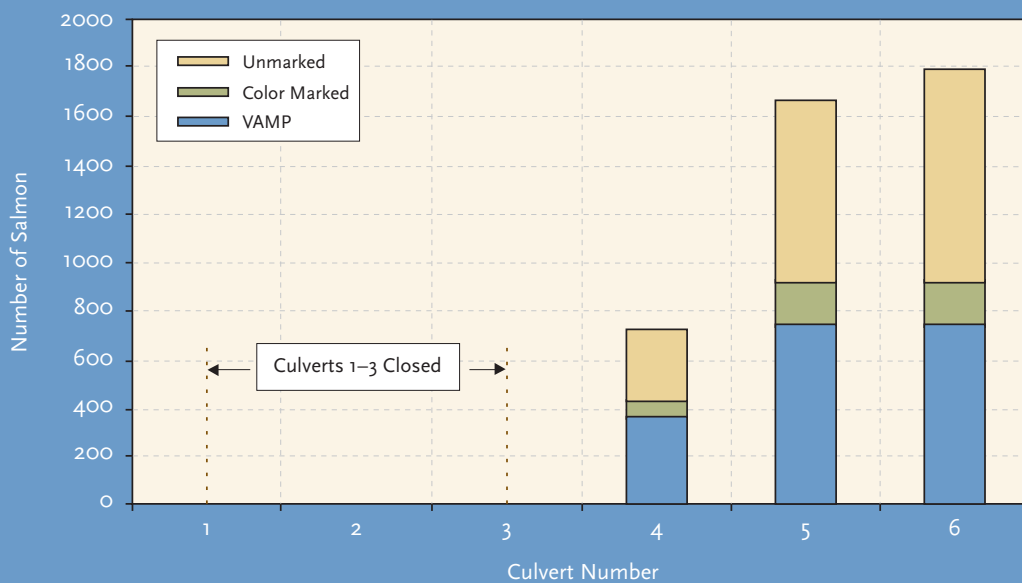
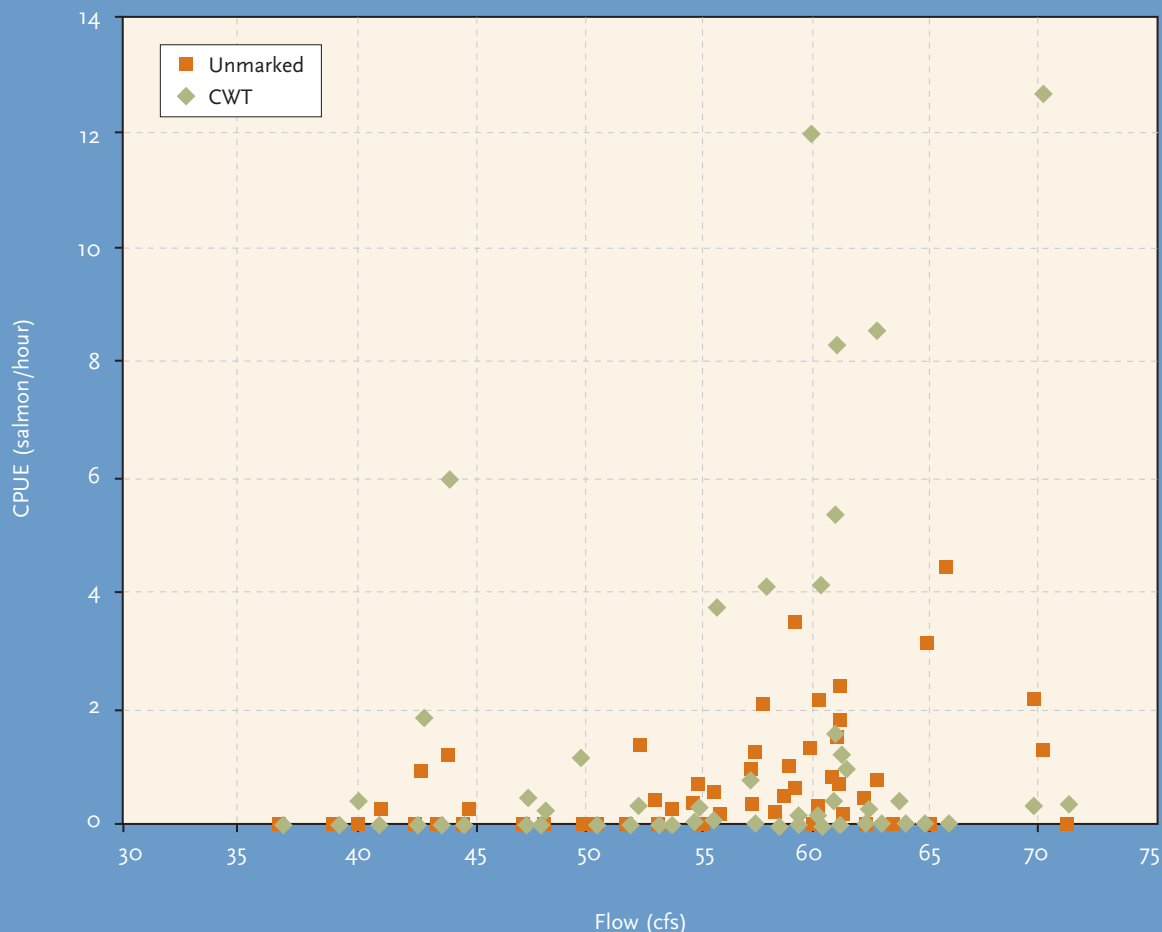

FIGURE 4-7

Relationship between salmon entrainment and flow in culvert number 4.



DISCUSSION

Although only half of the culverts were open during the VAMP experiment, some patterns in salmon entrainment were similar to previous years, e.g. higher entrainment at night, and more salmon were entrained from the first releases than the second releases. Interestingly, with fewer open culverts, the overall mean salmon entrainment rate was higher this year than in previous years. The higher entrainment rate was mostly due to the non VAMP salmon. It is possible that the salmon that would normally be entrained in the first three culverts, which were closed, were lingering around the culvert structure and some were subsequently entrained in the three open culverts. Even though the VAMP released salmon loss index was lower than in 2002, the rate at which the salmon were entrained was similar. If all six

culverts were open in 2003, the estimated VAMP salmon loss index of 1.4% (estimated by multiplying the 3 culvert loss index by 2) would be similar to last year's loss index.

Tidal stage may affect salmon entrainment. Although the mean entrainment rate between the flood and ebb tides was similar, a closer look at when the salmon were released and when they first arrived at the HORB reveals that there are some tidal entrainment differences. As in previous years, more salmon were entrained from the first set of VAMP releases than the second set of releases. This difference could be due to the tides, assuming the survival rate to the HORB was the same for each of the releases. The first evening release at Mossdale resulted in the highest entrainment near dusk: 469 of the Mossdale salmon were entrained within 3.5 hours of their release.

However, seven days later, only 5 of the evening released Mossdale salmon were entrained within 3 hours of their release. The highest entrainment occurred closer to dawn: 240 salmon. After the first VAMP Mossdale release, a relatively strong ebb tide occurred during the afternoon and evening. Low slack water occurred soon after dark. The low tide caused a relatively large head difference between upstream and downstream water levels as salmon arrived at the HORB. The resulting increase in flow through the culverts, due to the head difference, probably played a role in the high entrainment of Mossdale salmon. In contrast, a week later, high slack water occurred at dusk. Consequently, there was less head difference between upstream and downstream water levels which may have contributed to the lower salmon entrainment. The following morning, when the low tide occurred, salmon entrainment increased considerably. The Mossdale evening results are similar to last year's VAMP results which suggested entrainment is affected by tidal stage near the HORB. 

The results for the Mossdale evening releases were different than the day releases. More salmon were entrained from the two evening releases than for all the other VAMP releases combined. Very few of the Mossdale day released fish were caught. This is also in contrast to the previous years when the daytime released fish at Mossdale were typically entrained at a slightly higher rate (1.2%) than they were in 2003 (0.1%). The Mossdale day released salmon that were entrained followed the same pattern as the evening released fish. More salmon were entrained during the evening for the first release and more during the early morning for the second release. It is also possible the day and evening released fish are behaving differently as they move downstream. The day released fish could be migrating down the main channel as they pass the barrier. The evening released fish could be migrating closer to shore, and lower in the water column, where they are more vulnerable to entrainment. The overall higher salmon entrainment at night, than during the day, is similar to previous years' results. The higher nighttime entrainment results of VAMP salmon could be confounded by the daytime release of the salmon. Due to the timing of the VAMP release and the distance of the release sites from the HORB, a majority of the fish may pass by the barrier at night.

Diel entrainment of unmarked salmon differed from the VAMP salmon. Overall, 59% of the entrained VAMP salmon were caught at night compared to 92% of the unmarked salmon. In 2002, about 75% of both the entrained VAMP and unmarked salmon were caught at night. The proportionately higher

The results for the Mossdale evening releases were different than the day releases. More salmon were entrained from the two evening releases than for all the other VAMP releases combined. Very few of the Mossdale day released fish were caught.

entrainment of unmarked salmon at night, when compared to the VAMP salmon, suggests the VAMP released fish are not behaving the same as the unmarked fish at the HORB. However, without knowing how many unmarked salmon passed the barrier and what percent was entrained, we can only speculate whether this difference is meaningful. In contrast to the diel results, the tidal results were similar to the overall VAMP salmon tidal results. Entrainment on the flood and ebb tides was similar.

Results from the Entrainment Special Study are similar to last year's Entrainment Special Study results. More color-marked salmon were entrained on a flood tide than on an ebb tide, and more were entrained at night than during the day. Marked salmon were entrained at the highest rate during a night-flood for the first release. Very few color-marked salmon were entrained on the night-ebb, day-flood and day-ebb. During the second release, slightly more salmon were caught on the night-ebb. The reason for the low entrainment during the first release is unknown. Although only three culverts were open, the overall color-marked salmon entrainment was similar to last year (1.3% compared to 1.7%). It is possible attraction to the culvert structure, or localized current patterns caused the salmon to linger near the culverts and be entrained.

The low fish entrainment in culvert number 4 was surprising. Salmon entrainment was roughly half of the entrainment in culvert numbers 5 and 6. Debris or something could have been partially obstructing culvert number 4. The measured flows through the culvert were lower than the calculated flows. However, the lower flows in the culvert could be due to net resistance or other factors that affected all three culverts equally. We were unable to measure flows in all three culverts to see if there was a difference among culverts. If entrainment is



It is recommended that VAMP continue delaying the first salmon release by at least 5 days after the closure of the HORB. The delay allows for the completion of the barrier and minimizes the field crew's exposure to heavy equipment operation. The split releases at Mossdale should also be continued to help us better understand how tidal-diel interactions affect salmon entrainment at the HORB.

affected by the amount of flow through the culvert, then higher salmon entrainment should occur at higher flows. In culvert number 4, there was no relationship between CWT salmon entrainment and flow, and only a slight positive relationship between increasing flow and entrainment of unmarked salmon. The reduced catch of salmon in culvert number 4 relative to the other culverts suggest something might have been affecting the flow through the culvert and thus affecting the flow-entrainment relationship.

In summary, the results from the 2003 Entrainment Monitoring Study and the Entrainment Special Study suggest salmon are more vulnerable to entrainment at night. The tidal effects on entrainment are still unclear. Water velocities through the culverts are greatest on a low tide, near slack water. Salmon entrainment should be highest at this time which was somewhat evident for the Mossdale released fish. However, no significant relationship was found between CWT salmon entrainment and flow through culvert number 4. Only a weak positive relationship was found for unmarked salmon entrainment and flow in culvert number 4. The changing hydraulics surrounding the barrier as the tide changes effects flows near the culverts which may affect entrainment. Salmon smolt behavior and relative abundance near the barrier may play an important role in entrainment vulnerability.

It is recommended that VAMP continue delaying the first salmon release by at least 5 days after the closure of the HORB. The delay allows for the completion of the barrier and minimizes the field crew's exposure to heavy equipment operation. The delayed VAMP salmon releases also allows time for any loose material near the culverts to pass through the culverts before the nets are attached. In 2003, no samples were lost to gravel accumulation in the nets. The split releases at Mossdale should also be continued to help us better understand how tidal-diel interactions affect salmon entrainment at the HORB. If feasible, a release should be made at noon and midnight.

CHAPTER 5

Salmon Smolt Survival Investigations

One of the primary objectives of the VAMP program is to identify how San Joaquin River flows and SWP and CVP export rates, with the HORB in place, affect the survival of juvenile Chinook salmon emigrating from San Joaquin River system. This section describes the methods used to conduct the VAMP 2003 Chinook salmon smolt survival investigations, and presents the calculated survival indices, absolute survival estimates and combined differential recovery rates for coded-wire tagged juvenile Chinook salmon released during the VAMP 2003 test period. We also analyzed how the survival varied with flow, and flow relative to exports, with and without the HORB. Ocean recovery information on past releases and catches of unmarked juvenile salmon at Mossdale and in CVP/SWP salvage are also discussed. Additional data and information related to the salmon survival investigations are presented in Appendix C.

CODED-WIRE TAGGING

Merced River Fish Facility Chinook salmon smolts, released as part of VAMP 2003, were coded-wire tagged (CWT) between March and early April. After the salmon were tagged, they were held in the hatchery for at least 21 days before being released. Sub-samples of these salmon were measured (for fork length) and checked for retention of tags a day or two prior to release. Sub-samples were comprised of approximately 200 salmon collected from the top, middle, and bottom of the release group's raceway. Although tag detection is usually high, all salmon from the sub-samples without a detected tag were sacrificed to verify the accuracy of the CWT detection process. Sacrificed salmon were dissected to determine whether they contained a non-magnetized tag, an undetected tag, or no tag. Each CWT code within a release group was held separately at the hatchery with the exception of the two Durham Ferry releases. Each of these releases was comprised of three CWT codes that were held together at the hatchery.

At release, an additional sub-sample of 25 salmon was sacrificed from each tag group to verify CWT code, except at Durham Ferry. Fifty fish were sampled from each of the Durham Ferry releases because tag codes were combined prior to release.

Coded-wire tag retention rates were typical in 2003, ranging between 93 and 97.5% (Table 5-1). Coded-wire tag retention rates appeared higher than last year, with an overall retention rate of 94.5% for 2003 VAMP groups compared to 90.5% for 2002. Coded-wire tag retention rates were used to estimate the effective release size used in calculating survival indices (Table 5-1). The effective number released (ER) was calculated using the following equation:

$$ER = (T - M) \times TR$$

Where:

T = estimated number transported,

M = number of mortalities during release and transport (includes those sacrificed as part of the net pen evaluations), and

TR = CWT retention rate

CODED-WIRE TAG RELEASES

Two sets of CWT salmon releases were made as part of the 2003 VAMP experiment. The first set occurred on April 21 at Durham Ferry, April 22 at Mossdale, and April 25 at Jersey Point. The second set of releases occurred on April 28 at Durham Ferry, April 29 at Mossdale, and May 2 at Jersey Point.

For each set of releases approximately 75,000 salmon, divided among three CWT codes with approximately 25,000 fish, were released at Durham Ferry. Approximately 50,000 fish, divided between two CWT codes, were released at Mossdale. Approximately 25,000 fish with one CWT code were released at Jersey Point (Table 5-1). Prior to VAMP 2000, all CWT groups were trucked from the hatchery and released as a single group. However, since VAMP 2000, a new transport trailer with three tanks has allowed each CWT group to be transported to its

TABLE 5-1
Coded-wire tag (CWT) retention rates and estimated release numbers
for juvenile chinook salmon released for VAMP 2003

Release Site	Release Date	CWT Code	CWT Retention Sample Size	CWT Retention %	Estimated Number Transported	Mortalities After Transport ¹	Estimated Number Released	Effective Number Released
Durham Ferry ²	4/21/03	06-02-82	199	94.97	25,862	114	25,748	24,453
		06-02-83		94.97	27,414	114	27,300	25,927
		06-27-42		94.97	25,458	114	25,344	24,069
Mossdale	4/22/03	06-27-43	201	94.53	26,955	284	26,671	25,212
		06-27-48	200	93.50	26,464	292	26,172	24,471
Jersey Point	4/25/03	06-27-44	200	93.00	26,504	252	26,252	24,414
Durham Ferry ²	4/28/03	06-27-45	200	95.00	26,121	137	25,984	24,685
		06-27-46		95.00	26,651	137	26,514	25,189
		06-27-47		95.00	26,061	137	25,924	24,628
Mossdale	4/29/03	06-27-49	189	93.12	26,028	61	25,967	24,180
		06-27-50	201	94.03	26,061	169	25,892	24,346
Jersey Point	5/2/03	06-27-51	200	97.50	26,615	264	26,351	25,692

¹ Mortalities include juvenile Chinook salmon held and later sacrificed for the net pen studies.

² Coded-wire tag codes were combined at the hatchery. Therefore, CWT retentions are for all three tag codes combined and mortalities were divided equally among the three tag codes.

TABLE 5-2
Release time, temperatures, fork length (FL), and effective number released for juvenile
Chinook salmon released for VAMP 2003, by coded-wire tag (CWT) code.

Release Site	Date	CWT Code	Release Time	Truck Temp (°F)	Release Temp (°F)	Average FL (mm)	Effective Number Released
Durham Ferry	4/21/03	06-02-82	1245	51.8	59.0	86	24,453
		06-02-83		51.8	59.0		25,927
		06-27-42		51.8	59.0		24,069
Total							74,449
Mossdale	4/22/03	06-27-43	1200	51.8	58.6	86	25,212
		06-27-48	1800	55.4	59.9	86	24,471
Total							49,683
Jersey Point	4/25/03	06-27-44	1800	56.0	62.0	88	24,414
Durham Ferry	4/28/03	06-27-45	1215	53.0	62.0	86	24,685
		06-27-46		53.0	62.0		25,189
		06-27-47		53.0	62.0		24,628
Total							74,502
Mossdale	4/29/03	06-27-49	1245	55.0	60.0	87	24,180
		06-27-50	1800	55.0	61.0	88	24,346
Total							48,527
Jersey Point	5/02/03	06-27-51	1145	55.0	59.0	89	25,692

release site in a separate tank and released. As mentioned earlier, each Durham Ferry group consisted of three tag codes which were already mixed at the hatchery and were therefore transported in a large, single tank, release truck.

Release strategies were similar to VAMP 2002, except at Mossdale. Both Durham Ferry releases were made from the more desirable location alongside the river, instead of from the top of the levee. The nearby agricultural diversion was turned off from the time of the releases until several hours after each release to allow the tagged salmon time to disperse from the release site. Releases at Jersey Point were made one hour prior to the beginning of the flood tide to increase dispersion of the tagged fish before they passed Antioch and Chipps Island. Water temperatures in the hatchery trucks and at the release sites were measured immediately prior to release (Table 5-2). In all cases, differences between water temperatures in the transport trucks and the release site were less than 5°C (9°F). Releases at Mossdale and Durham Ferry were not made on any specific tidal condition.

Both of the Mossdale releases were divided by CWT code, into afternoon (around 1200) and evening (around 1800) releases (Table 5-2). The two tag groups were released at different times to test day and night differences in entrainment at the HORB (see Chapter 4). We also planned to test if survival differed between the two release strategies; however, low recoveries prevented evaluation of survival by release time this year. If this release strategy is continued, we may be able to test for differences in survival in the future.

WATER TEMPERATURE MONITORING

Water temperature was monitored during the VAMP 2003 study using individual computerized temperature recorders (e.g., Onset Stowaway Temperature Monitoring/Data Loggers). Water temperatures were measured at locations along the longitudinal gradient of the San Joaquin River and interior Delta channels between Durham Ferry and Chipps Island—locations along the migratory pathway for the juvenile Chinook salmon released as part of these tests (Appendix C-1). Water temperature was recorded at 24-minute intervals throughout the period of the VAMP 2003 investigations. Water temperatures were also recorded within the hatchery raceways at the Merced River Hatchery coincident with the period when juvenile Chinook salmon were being tagged. These temperature recorders were later transported with the juvenile salmon released at Durham Ferry.

Results of water temperature monitoring within the Merced River Fish Facility showed that juvenile Chinook salmon were

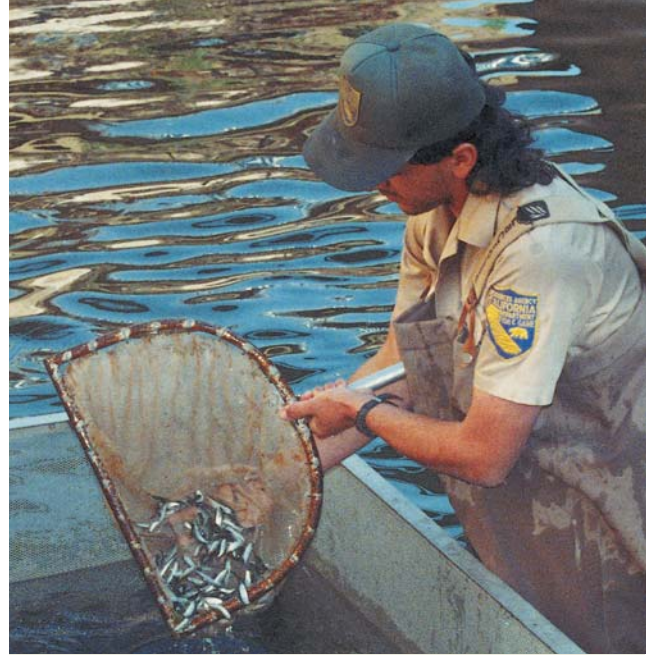

Results of water temperature monitoring showed that water temperatures at the release locations and throughout the lower San Joaquin River and Delta (Appendix C-2) were higher than those at the hatchery.

reared in, and acclimated to, water temperatures of approximately 10.5°–14°C (51°–57°F) prior to release into the lower San Joaquin River (Figures 5-1 and 5-2). Results of water temperature monitoring at Durham Ferry and Mossdale following the first and second sets of VAMP 2003 releases are compared in Figures 5-3 and 5-4. No temperature data were available for Jersey Point (the recorder was lost). Results of water temperature monitoring showed that water temperatures at the release locations and throughout the lower San Joaquin River and Delta (Appendix C-2) were higher than those at the hatchery. Water temperatures measured within the lower San Joaquin River and Delta were not expected to result in mortality or adverse effects to emigrating juvenile Chinook salmon released as part of the VAMP 2003 investigations. A comparison of water temperatures measured at Durham Ferry during VAMP 2002 and VAMP 2003 (Figure 5-5a) showed that temperatures were similar during the two years. A comparison of temperatures at downstream locations showed that temperatures were generally higher during VAMP 2002 when compared to the VAMP 2003 test period (Figures 5-5b–5-5d).

WATER TEMPERATURE MONITORING RESULTS:

Water temperatures measured within the lower San Joaquin River and Delta were not expected to result in mortality or adverse effects to emigrating juvenile Chinook salmon released as part of the VAMP 2003 investigations.

FIGURE 5-1

Merced River Fish Hatchery —1.

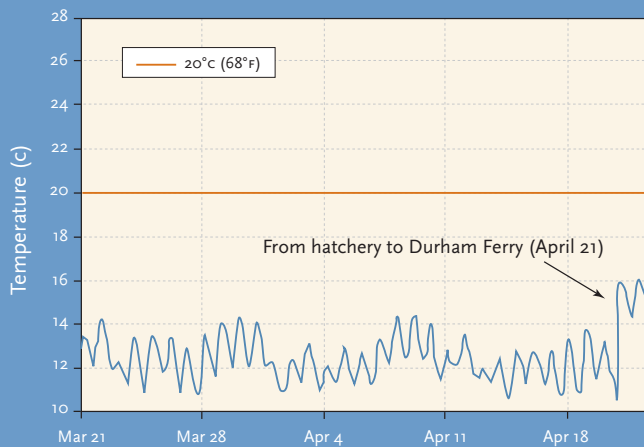

FIGURE 5-2

Merced River Fish Hatchery —2.

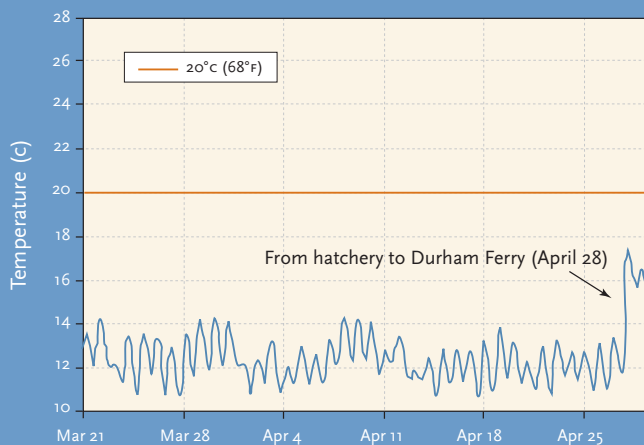

FIGURE 5-3

Site 1—Durham Ferry.

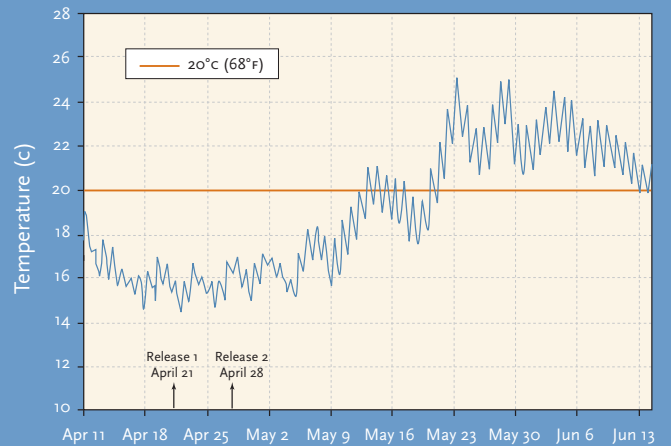

FIGURE 5-4

Site 2—Mossdale.

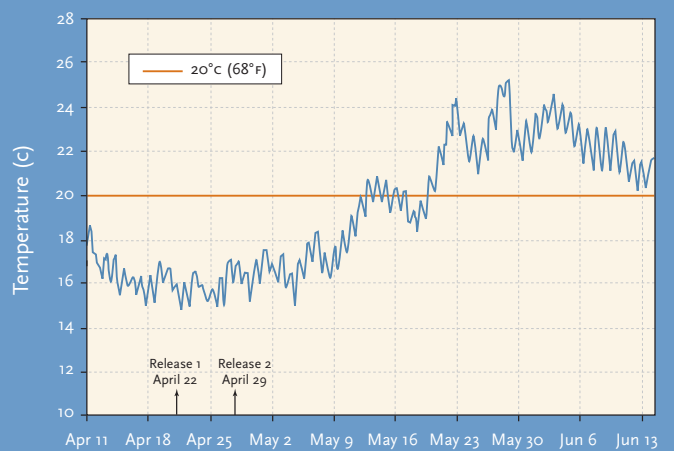

FIGURE 5-5A

Site 1—Durham Ferry.

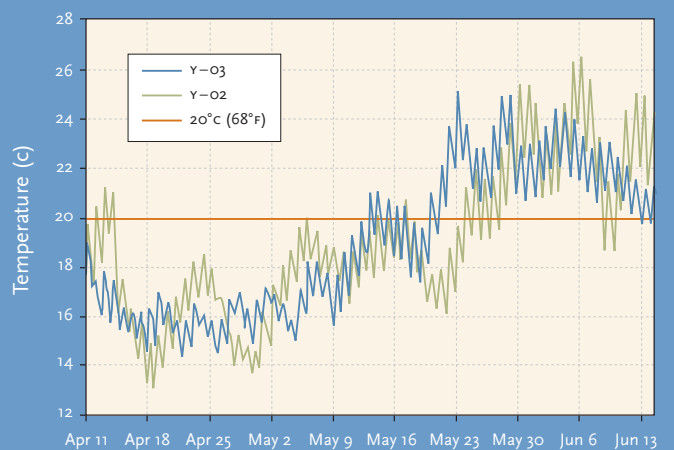
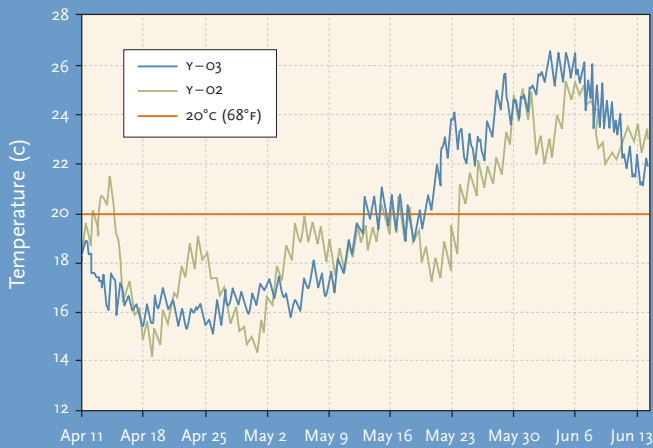
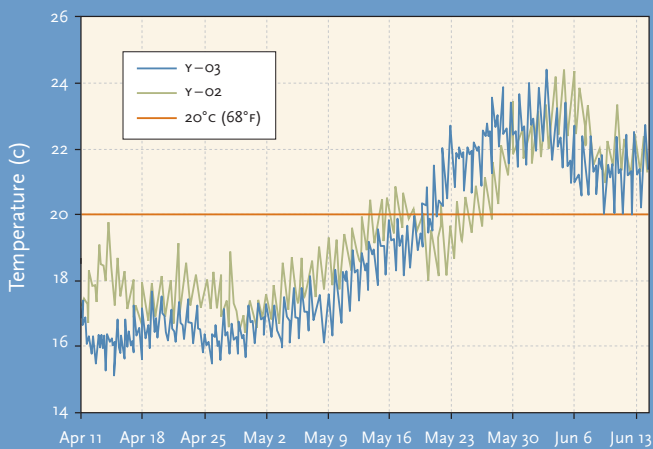

FIGURE 5-5B

Site 4—DWR Monitoring Station.

**FIGURE 5-5C**

Site 7—1/2 mile upstream of Channel Marker 13.

**FIGURE 5-5D**

Site 10—Chipp's Island.

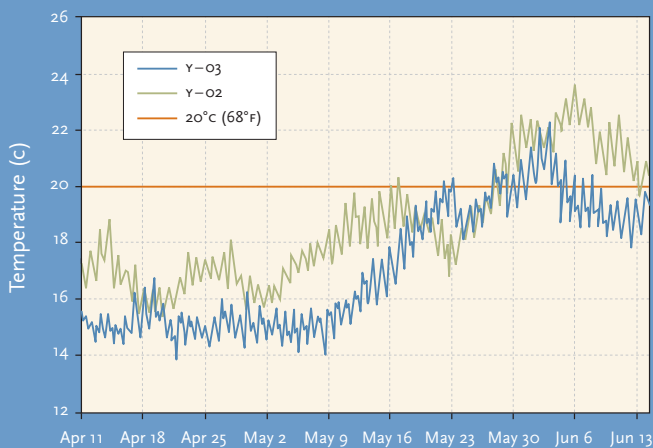
**POST-RELEASE NET PEN STUDIES****Survival and Condition**

Post-release survival and condition of marked salmon were evaluated as part of the VAMP program using sub-samples of marked salmon from each release group. Twenty-five salmon from each CWT group were evaluated for general condition immediately after release. To assess general condition, fork length in millimeters, weight in grams, and six other characteristics were examined (Table 5-3). Other obvious abnormalities or deformities were also noted. To assess short-term effects of handling, transport, and release, an additional sub-sample of approximately 200 salmon from each tag code were held at the respective release sites for 48 hours. Of these, 25 were measured, weighed, and examined for the six general condition characteristics. The remaining fish were measured, weighed, and evaluated for adipose fin clips and short-term mortality. Because CWT codes were held together for the Durham Ferry releases, 50 fish from these release groups (all three CWT codes combined) were evaluated for general condition immediately and 48 hours after release, and two net pens with approximately 200 fish each were held in order to maintain consistency with the other release groups. In all, 499 juvenile Chinook salmon were examined for the six general condition characteristics, and 2,038 (including the 499 examined for general condition) were measured, weighed, and assessed for mortality and presence/absence of an adipose fin clip.

Results of the evaluations of the 499 marked salmon examined for the six general condition characteristics showed few abnormalities (see Appendix C-3). The majority of fish examined had normal coloration (99.2%), no fin hemorrhaging (100%), normal eye characteristics (99.2%), and normal gill color (92.4%). Scale loss ranged from 1% to 35% and averaged 8.6%. Other abnormalities included: fin rot (1%), dorsal fin splitting (0.8%), partial operculum (1%) and ragged dorsal fins (1%). In addition, this year 65 (3%) Chinook salmon had a poor or incomplete adipose fin clip, while 11 (0.5%) had no fin clip. Of the 2,038 juvenile Chinook salmon examined, there were 11 mortalities. In contrast, we observed no mortalities in 2002.

Tag Quality Control

Though rare, in the past, salmon from different release groups have been unintentionally mixed at some point prior to release. The subset of 25 salmon from each tag group (a total of 25 from each of the Durham Ferry net pens) evaluated for condition as described above were sacrificed to verify purity of tag codes.



TABLE 5–3
Smolt condition characteristics assessed for post-release net pen studies.

	Normal	Abnormal
Eyes	Normally shaped	Bulging
Color	High contrast dark dorsal surface and light sides	Low contrast dorsal surface and sides, coppery color
Fin Hemorrhaging	No blood or red at base of fins	Blood at base of fins
Percent Scale Loss	Lower relative numbers better based on 0–100% scale loss	Higher relative numbers worse based on 0–100% scale loss
Gill Color	Dark beet red to cherry red gill filaments	Light red to gray gill filaments
Vigor	Active swimming (prior to anesthesia)	Lethargic or motionless (prior to anesthesia)

In 2003, there were no errant tags codes associated with the VAMP 2003 net pen study. The remaining fish from each release group that were held in the net pens were archived in a freezer for further evaluation of tag code mixing if deemed necessary.

Health and Physiology

Personnel from the USFWS’s California-Nevada Fish Health Center conducted physiological studies on a sub-sample of the juvenile Chinook salmon used in the VAMP study (Nichols and Foott 2003). Results of this work are summarized below.

A total of 284 Merced River Fish Facility fish were examined from the six release groups following transport to release sites at Durham Ferry, Mossdale, and Jersey Point. A general health inspection for viral, *Renibacterium salmoninarum* (Bacterial Kidney Disease agent) and systemic bacterial infection was performed on 60 fish from the first Mossdale release. Additional assays were conducted on the remaining 224 fish including: (1) internal and external abnormalities were recorded for each smolt; (2) smolt development was assessed (gill tissue was analyzed for ATPase activity from 64 fish, spread out over all release groups); and, (3) kidney tissue from 48 fish was examined for presence of *Tetracapsula bryosalmonae*, the parasite responsible for Proliferative Kidney Disease (PKD). To assess stress recovery, blood plasma levels of chloride, sodium, lactate, glucose, total protein, and cortisol were measured. At each release site, blood samples were taken from 7 to 16 fish directly out of the transport truck, and after being held in net pens for two and four hours after release. Because of time and personnel constraints, samples were not taken for fish held two and four hours after release for the second Mossdale release. Additional blood samples were taken and analyzed at 24 hours post-release for both Durham Ferry releases and for the second Jersey Point release.

No viral pathogens or *R. salmoninarum* were detected in the 60 fish sample. Low levels of bacteria common in the skin and gastrointestinal tract of fish were isolated from 30% of these fish. These isolations were not considered to be significant health risks. *Tetracapsula bryosalmonae* was detected in 63% of the 48 kidneys examined by histology and 21% showed severe inflammation caused by the parasite. Gross clinical signs (swollen kidney or spleen) of PKD were observed in 11% of the 222 smolts examined. Proliferative Kidney Disease infection was more prevalent in the second set of releases (21% for second releases combined) than the first set (3% for first releases combined; $p < 0.001$, z-test). Because PKD can reduce performance due to associated kidney dysfunction and anemia, smolts in the first release groups may have had higher survival than cohorts in the second release groups.

All sample groups demonstrated similar levels of smolt development as demonstrated by gill ATPase activity. Observed ATPase levels were consistent with fish undergoing smoltification.

There were few consistent patterns in blood chemistry values among the release groups. It appears that net pen confinement failed to reduce stress on the transported fish as indicators of stress (cortisol, glucose, and lactate) tended to remain altered throughout sampling (up to 24 hours). Plasma chloride was below normal in four of five groups at four hours post-release, but did return to normal in the 24 hour samples. No biologically significant shifts in plasma protein levels were detected in any group. Comparisons of the release groups are complicated by differences in transport time and handling prior to placement in net pens. The variations created by these differences may hide some trends in blood chemistry values that signal survival differences in the release groups. There may also be problems with extrapolating blood chemistry values of smolts held in net pens to those released into the river.

TABLE 5-4
Survival Indices at Antioch and Chipps Island and expanded salvage at the Central Valley Project (CVP) and State Water Project (SWP) Fish Facilities for the 2003 VAMP Study (drafted: 10/22/03)

Tag Code	Release Site	Date	Effective Number Released ¹	ANTIOCH				
				Number Recovered	Minutes Fished ²	Fraction of Time Sampled ³	Survival Index ⁴	Group Index
San Joaquin								
06-02-82	Durham Ferry		24,453	1	560	0.389	0.008	
06-02-83	Durham Ferry		25,927	4	1140	0.396	0.028	
06-27-42	Durham Ferry		24,069	1	560	0.389	0.008	
Total		4/21/03	74,449	6	2790	0.388		0.015
06-27-43	Mossdale		25,212	2	1140	0.396	0.014	
06-27-48	Mossdale		24,471	2	1690	0.391	0.015	
Total		4/22/03	49,683	4	3370	0.390		0.015
06-27-44	Jersey Point	4/25/03	24,414	71	6828	0.395	0.530	
06-27-45	Durham Ferry		24,685	0	–	–		
06-27-46	Durham Ferry		25,189	0	–	–		
06-27-47	Durham Ferry		24,628	0	–	–		
Total		4/28/03	74,502	0			–	–
06-27-49	Mossdale		24,180	0	–	–		
06-27-50	Mossdale		24,346	0	–	–		
Total		4/29/03	48,526	0			–	–
06-27-51	Jersey Point	5/02/03	25,692	36	5622	0.390	0.258	

In summary, the incidence of clinical PKD was notably higher in smolts used for the second set of releases compared to smolts from the first set of releases. Consequently, survival of smolts from the second set of releases may be reduced in comparison to cohorts from the first releases. No biologically significant differences in smolt development or stress response were detected among fish from the different release times or sites. Plasma ion balance was disturbed in fish held in net pens for up to four hours post-release but returned to normal by 24 hours.

CODED-WIRE TAG RECOVERY EFFORTS

Coded-wire tagged salmon were recaptured at Antioch and Chipps Island, at CVP and SWP fish salvage facilities, and during sampling at HORB (for locations see Figure 1-1). Coded-

wire tagged salmon released upstream of, and at, Mossdale were also recovered in DFG Kodiak trawls at Mossdale but are not discussed in this report. Juvenile Chinook salmon with an adipose fin clip (which identifies CWT salmon) caught at any of these sampling locations were sacrificed, labeled, and frozen for CWT processing. Coded-wire tag processing was done by USFWS (Stockton) for fish recovered at Chipps Island, Antioch, and SWP and CVP salvage facilities. DFG Region IV processed salmon captured in the HORB fyke net sampling.

Coded-wire tags are processed by dissecting each tagged fish to obtain the half (0.5 millimeters) or full (1 millimeter) cylindrical CWT from the snout. Tags are then placed under a dissecting microscope and the numbers are read and recorded in a database. All tags were read twice, and any discrepancies

	CHIPPS ISLAND					Expanded Salvage Numbers ⁵	
	Number Recovered	Minutes Fished ²	Fraction of Time Sampled ³	Survival Index ⁴	Group Index	CVP	SWP
	0	–	–	–		24	0
	2	2394	0.277	0.036		12	0
	1	400	0.278	0.019		12	3
	3	2394	0.277		0.019		
	3	2379	0.275	0.056		0	0
	2	1185	0.274	0.039		0	0
	5	2379	0.275		0.048		
	57	4779	0.277	1.097		0	0
	0	–	–	–		12	0
	0	–	–	–		12	0
	0	–	–	–		0	0
	0						
	0	–	–	–		12	0
	1	400	0.278	0.019		0	0
	1	400	0.278		0.010		
	39	3460	0.267	0.739		0	0

¹The Effective Number Released is an estimate of the number of fish released with an adipose fin clip and CWT.

²The Minutes Fished is the number of minutes sampled between the first and last day of recovery.

³The fraction of time sampled is between the first and last day of recovery.

⁴The survival index is calculated using the formula: # recovered / (# released x fraction of time sampled x fraction of channel sampled)

⁵Expanded salvage numbers are: the number recovered in salvage/(minutes sampled/total minutes between samples)

were resolved by a third reader. Tags were archived for future reference. VAMP releases comprise a small portion of the total tagged salmon released in the Sacramento and San Joaquin system. Consequently, many tags recovered at Chipps Island, Antioch, the SWP and CVP salvage facilities, and other locations are from CWT releases not affiliated with VAMP. It is necessary to read all recovered tags to identify CWT recoveries related to VAMP.

SWP and CVP Salvage Recapture Sampling

Sampling at the CVP and SWP fish salvage facilities was conducted approximately every two hours. The number of marked salmon collected (raw salvage) was expanded based on the number of minutes sampled during each two hour time period.

The estimated expanded total number of CWT salmon, from each release group, was obtained by adding together the expanded number of each tag group for all time periods. Only CWT salmon recovered in the raw salvage collections were sacrificed for tag processing. Expanded salvage is only a portion of the direct loss experienced by juvenile salmon at the facilities as it does not include losses prior to, and associated with, pre-screen predation, screening, handling and trucking.

Expanded salvage numbers were low at the CVP (n = 84), and only three Chinook salmon were salvaged at the SWP (Table 5-4). These results are consistent with earlier studies showing that the HORB reduces the number of CWT salmon entrained at the fish facilities (Brandes and McLain, 2001). Additional VAMP fish were recovered during special studies at the SWP (n = 13).

Antioch Recapture Sampling

Fish sampling was conducted in the vicinity of Antioch on the lower San Joaquin River (Figure 1-1) using a Kodiak trawl. The Kodiak trawl has a graded stretch mesh, from 2-inch mesh at the mouth to 1/2-inch mesh at the cod-end. Its overall length is 65 feet, and the mouth opening is 6 feet deep and 25 feet wide. The net was towed between two boats, sampling in an upstream direction. Trawls were performed parallel to the left bank, mid-channel, and right bank to sample CWT salmon emigrating from the San Joaquin River. Each tow was approximately 20 minutes in duration.

All captured fish were transferred immediately from the Kodiak trawl to buckets filled with river water, where they were held for processing. Data collected during each trawl included: species identification and fork length for each fish captured, tow start time and duration, and location in the channel. Any fish mortalities or injuries were documented to comply with the Endangered Species Act permit requirements.

Juvenile Chinook salmon with an adipose fin clip were retained for later CWT processing while other fish were released at a location downstream of the sampling site immediately after identification, enumeration, and measurement.

Sampling at Antioch began April 21 and continued through May 20. Each day between 5:00 a.m. and 9:00 p.m., anywhere from 3 to 32 tows were conducted. In all, 800 Kodiak trawl samples were collected, for a total of 15,877 tow minutes. During sampling, 6,971 unmarked juvenile Chinook salmon were captured; 341 salmon with an adipose fin clip (and CWT) were collected, 117 from VAMP releases (Table 5-4) and 214 from other hatchery releases. In addition, 1,328 delta smelt, 16 Sacramento splittail, 29 unmarked steelhead, and 43 adipose fin clipped steelhead were caught during sampling.

Chippis Island Recapture Sampling

As part of VAMP 2003 recovery efforts at Chippis Island, trawling shifts were conducted twice daily between April 21 and May 31. This second shift has been conducted during the spring releases since 1998. The first shift began at sunrise, while the second shift ended at or after sunset, to incorporate the crepuscular periods of the day. Based on analysis of 24-hour sampling at Jersey Point in 1997 (Hanson, Hanson Environmental, unpublished data), greater numbers of juvenile Chinook salmon appear to be caught around sunrise and sunset. Therefore, targeting this crepuscular period and doubling total trawl effort at Chippis Island should increase the number of CWT salmon recaptured and reduce variability in VAMP survival indices. Sampling for other

studies occurs once daily between June 1 and June 14, and three days per week after June 16 and prior to April 21.

Midwater trawls were conducted at Chippis Island by towing the trawl net at the surface. The mouth of the net was 10 feet deep by 30 feet wide, and the total length was 82 feet. Aluminum hydrofoils were used on the top bridles and steel depressors, along with a weighted lead line, were used on the bottom bridles to keep the mouth of the net open. The net consisted of graded mesh starting with 4-inch mesh at the mouth and ending with a 1/4-inch cod end mesh.

To sample across the channel, trawling at Chippis Island was conducted in three distinct lanes: the north, south, and middle of the channel. Each lane was generally sampled at least three times per shift, with one lane sampled a fourth time during each shift. The lane sampled four times was chosen at random or selected by the boat operator based on flow conditions.

During the VAMP recovery period, 105 VAMP CWT Chinook salmon were recovered at Chippis Island (Table 5-4). In addition, 11,226 unmarked salmon, 711 CWT salmon from non VAMP experiments, 15 delta smelt, 11 Sacramento splittail, 12 unmarked steelhead, and 17 adipose fin clipped steelhead were collected.

VAMP CHINOOK SALMON CWT SURVIVAL

Survival Indices

Survival indices were calculated for marked salmon released at Durham Ferry, Mossdale, and Jersey Point and recovered at Antioch and Chippis Island. Survival indices (SI) were calculated using the formula:

$$SI = (R / (E * T * W))$$

Where:

R = the number recovered,

E = the effective number released,

T = the fraction of time sampled, and

W = the fraction of channel width sampled

The fraction of the channel width sampled at Chippis Island (0.00769) was calculated by dividing the net width (30 feet) by the estimated channel width (3,900 feet). The fraction of the channel width sampled at Antioch (0.01388) was calculated in the same manner, with the net width being 25 feet and the channel width being 1,800 feet. The fraction of time sampled at both locations was calculated based on the number of minutes sampled between the first and last day of catching each particular tag code or group, divided by the total number of minutes



Survival indices were calculated for each tag code to provide a sense of the variability associated with the group survival index.

in the time period. The fraction of time sampled for the VAMP 2003 release groups at Chipps Island was about 0.28, while at Antioch it was about 0.39 (Table 5-4).

Survival indices were calculated for each tag code to provide a sense of the variability associated with the group survival index. To generate the group survival index, the recovery numbers and release numbers were combined for the tag codes within a release group.

Individual and group survival indices to Antioch and Chipps Island of the CWT salmon released as part of VAMP 2003 are shown in Table 5-4. Survival indices have been reported to three significant digits, but we realize indices were not likely that precise. Survival indices were not corrected for the number of CWT fish recovered at the HORB or in sampling at Mossdale conducted by DFG Region IV.

The first set of VAMP releases appeared to survive at a higher rate than the second set of releases. The first Durham Ferry releases had survival indices to Antioch and Chipps Island of 0.015 and 0.019, respectively. The second Durham Ferry group had an unknown but likely lower survival rate since none were recovered at either location. The first releases at Mossdale had survival indices to Antioch of 0.015 and 0.048 to Chipps Island. No fish were recovered at Antioch from the second Mossdale release and the survival index to Chipps Island was 0.010. Survival indices for the two Jersey Point groups were 0.530 and 0.258 at Antioch and 1.097 and 0.739 at Chipps Island for

the first and second releases respectively. Why survival was lower for the second groups relative to the first groups is unknown but may be related to the higher incidence of PKD.

Survival indices for both sets of releases made at Durham Ferry and Mossdale were very low relative to releases made at Jersey Point (Table 5-4).

Chinook Salmon Survival Estimates and Combined Differential Recovery Rates

More important than the differences in survival indices between sets of releases is the comparison of absolute survival estimates and combined differential recovery rates (CDRR). Absolute survival estimates (AS_i) are calculated by the formula:

$$AS_i = SI_u / SI_d$$

Where:

SI_u = the survival index of the upstream group (Durham Ferry or Mossdale), to the recovery location

SI_d = the survival index of the downstream group (Jersey Point) to the recovery location and

i = recovery location (Antioch or Chipps Island).

Although referred to throughout this document as absolute survival estimates they are more aptly described as standardized or relative survival estimates. The combined recovery rate (CRR) is estimated by the formula:

$$CRR = R_{C+A} / ER$$

Where:

R_{C+A} = the combined recoveries at Antioch and Chipps Island of a CWT group, and

ER = the effective number released.

The combined differential recovery rate (CDRR) is calculated by the formula:

$$CDRR = CRR_u / CRR_d$$

Where:

CRR_u = the combined recovery rate for the upstream group (Durham Ferry or Mossdale), and

CRR_d = the combined recovery rate for the downstream group (Jersey Point).

The CDRR is another way to estimate survival between the upstream and downstream release locations. It is similar to calculating absolute survival estimates, but does not expand estimates

FIGURE 5-6

Combined Differential Recovery Rates (CDRR) and (+/- 1 and 2 standard errors) of coded wire tagged (CWT) smolts released in 2003 at Mossdale and Jersey Point (Mossdale) and Durham Ferry and Jersey Point (Durham Ferry) for the first (1) and second (2) release groups. CWT smolts were recovered at Antioch and Chipps Island.

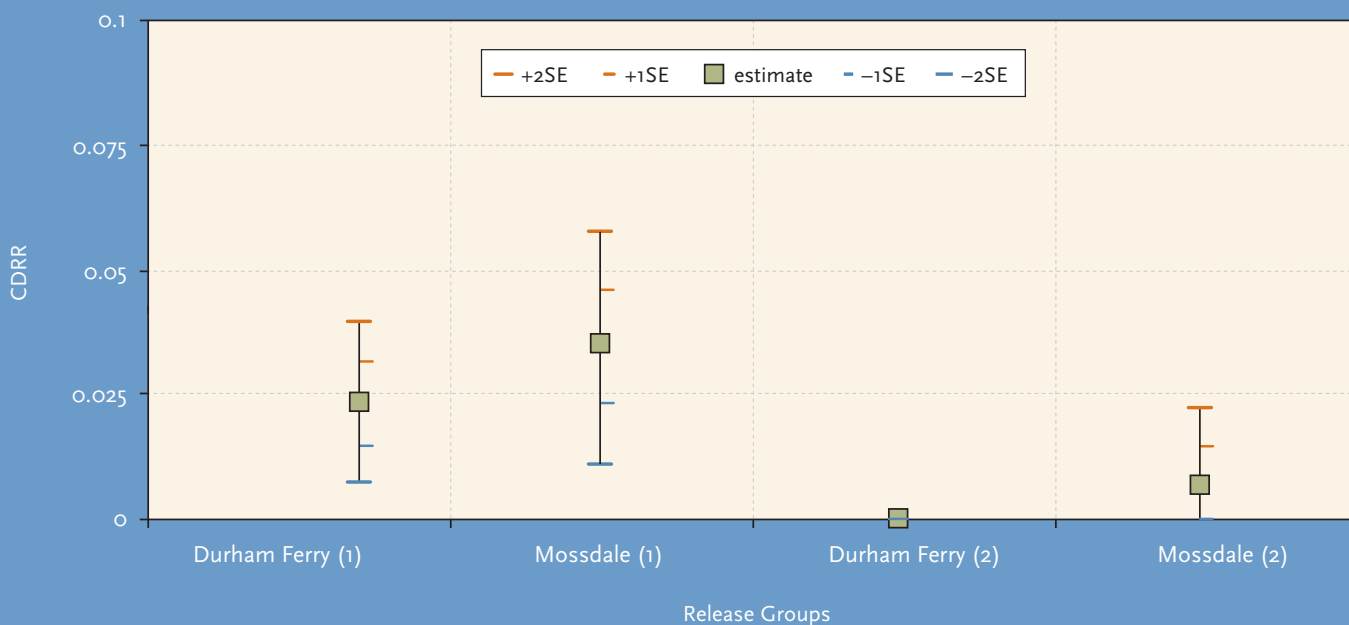
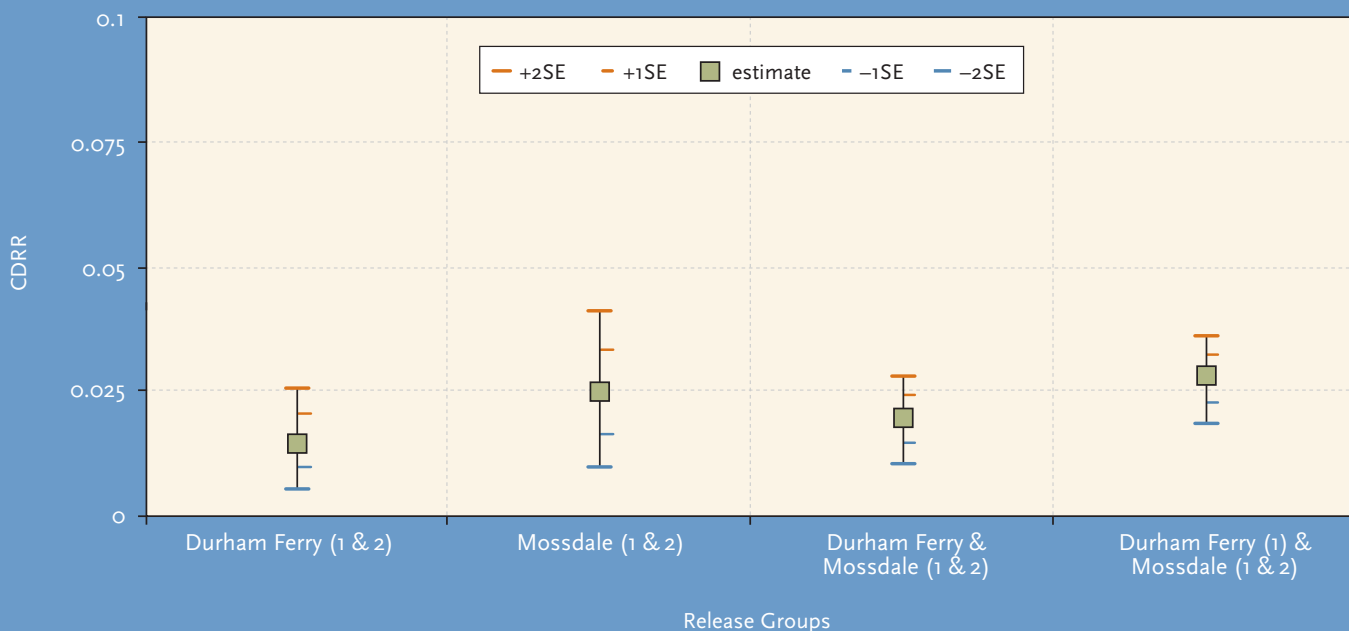

FIGURE 5-7

Pooled, Combined Differential Recovery Rates (CDRR) and (+/- 1 and 2 standard errors) of CWT smolts released in 2003 at Durham Ferry and Jersey Point (Durham Ferry) and Mossdale and Jersey Point (Mossdale) for the first (1) and second (2) release groups and for the combined Durham Ferry and Mossdale release groups (with and without the second Durham Ferry release group). Recoveries were made at Antioch and Chipps Island.



based on the fraction of the time and space sampled. At times the differential recovery rate (DRR) is reported which is similar to the CDRR but only uses recovery numbers from one recovery location—either Chipps Island or the ocean fishery.

The CDRR and the absolute survival estimates should not be very different as (1) the fraction of the time sampled is similar between groups for a recovery location and (2) the fraction of the channel width sampled at each recovery location is a constant. Neither would change the relative differences between groups. However, combining the recovery numbers from Antioch and Chipps Island could result in different survival estimates between the two methods.

Variance and standard errors were calculated for the CDRRs based on the Delta method recommended by Dr. Ken Newman. Plus or minus two standard errors are roughly equivalent to the 95% confidence intervals around the CDRR. Plus or minus one standard error equates to roughly the 68% confidence intervals for normally distributed data (Ken Newman, University of St. Andrews, Scotland, personal communication). In comparing survival between reaches and replicates, the confidence intervals were used to determine if CDRRs were significantly different from each other. If the 95% confidence intervals overlapped CDRRs were not considered statistically different from each other. Differences observed using the lower level of confidence (68%) are noted. It is not clear how variances, standard errors, or confidence intervals could be generated for absolute survival estimates.

Absolute survival estimates and CDRRs should be more robust for comparing survival between groups, recovery locations, and years, since using ratios between upstream and downstream

groups theoretically standardizes for differences in catch efficiency between recovery locations and years. Both estimates of absolute survival and CDRRs were calculated for CWT releases as part of VAMP 2003, as in past years. An additional estimate of absolute survival will be possible from recoveries made in the ocean fishery, two to four years following release.

Although the first groups released at Durham Ferry and Mossdale appeared to survive slightly better than the second groups when evaluated using the absolute survival estimates and CDRRs (Table 5-5), the CDRRs of the two Mossdale groups were not statistically different at the 95% confidence level ($p < 0.05$ level). They were significantly different using the 68% confidence level (Figure 5-6). No recoveries were made for the second Durham Ferry group at either recovery location, thus the second groups appeared to survive at a lower rate than the first groups. In addition, no recoveries were made at Antioch for the second Mossdale group.

The first Mossdale group appeared to survive slightly better than the first Durham Ferry group using the absolute survival estimates generated using Chipps Island recoveries and CDRR (Table 5-5). The first Mossdale group appeared to survive about the same as the first Durham Ferry group using the Antioch recoveries (Table 5-5). The CDRR indicated that differences were not significant (Figure 5-6). Fish released at Durham Ferry are thought to incur additional mortality since it is 11 miles farther upstream than Mossdale.

Because there were no significant differences between the CDRRs of the two Mossdale release groups, the groups were pooled and a new CDRR (0.025) and standard error were calculated (Figure 5-7). The first Durham Ferry group was also

TABLE 5-5
Group survival indices (SI) and absolute survival estimates (AS) combined differential recovery rates (CDRR) using recoveries at Antioch, Chipps Island or both for coded wire tagged Chinook salmon released as part of VAMP 2003.

Release Site	Date	Antioch Group SI	Antioch Group AS	Chipps Group SI	Chipps Group AS	Combined Differential Recovery Rate
Durham Ferry	4/21/03	0.015	0.028	0.019	0.017	0.023
Mossdale	4/22/03	0.015	0.028	0.048	0.043	0.035
Jersey Point	4/25/03	0.530		1.097		
Durham Ferry	4/28/03	–	–	–	–	–
Mossdale	4/29/03	–	–	0.010	0.014	0.007
Jersey Point	5/02/03	0.258		0.739		

TABLE 5-6
Recovery timing of juvenile CWT salmon released as part of VAMP 2003

Tag Code	Release Site	Release Date	ANTIOCH				
			Number Recovered	First Day Recovered	Last Day Recovered	Days to First Rec.	Days at Large
06-02-82	Durham Ferry		1	5/4	5/4		13
06-02-83	Durham Ferry		4	4/30	5/1		10
06-27-42	Durham Ferry		1	4/30	4/30		9
Total		4/21/03	6	4/30	5/4	9	13
06-27-43	Mossdale		2	4/30	5/1		9
06-27-48	Mossdale		2	5/3	5/5		13
Total		4/22/03	4	4/30	5/5	8	13
06-27-44	Jersey Point	4/25/03	71	4/26	5/7	1	12
06-27-45	Durham Ferry		0	–	–		
06-27-46	Durham Ferry		0	–	–		
06-27-47	Durham Ferry		0	–	–		
Total		4/28/03	0				
06-27-49	Mossdale		0	–	–		
06-27-50	Mossdale		0	–	–		
Total		4/29/03	0				
06-27-51	Jersey Point	5/02/03	36	5/3	5/12	1	10

combined with the two Mossdale groups (Figure 5-7) since there were no statistical differences in the CDRRs at the 95% level between groups (Figure 5-6). Since no recoveries were made for the second Durham Ferry group, we were uncertain whether it was appropriate to combine Durham Ferry groups and include the second Durham Ferry group in the pooling with the Mossdale groups. To address this, CDRRs were calculated using the two sets of pooled data to determine if they were statistically different. The CDRR for the pooled two Durham Ferry and Mossdale releases was 0.019. Without the second Durham Ferry release included the CDRR was 0.027. CDRRs of the two sets of pooled data were not significantly different. The pooled CDRR for the two Durham Ferry releases was 0.015 (Figure 5-7).

TRANSIT TIME

Data on transit times for marked salmon from release to recapture sites during VAMP 2003 is summarized in Table 5-6. The transit time (from release location to Antioch and Chipps Island) for both sets of releases was similar. Recoveries of all groups were made within 13 days after release. It is interesting that the Jersey Point groups were still recovered 10 to 12 days after release, similar to groups released upstream. Daily recovery of each release group by tag code and sampling effort is shown in Appendix C-4.

Transit time for the CWT groups to the CVP and SWP fish facilities varied more than transit times to Antioch and Chipps Island. Coded wire tagged fish released as part of the first Durham Ferry group arrived at the facilities earlier (tag group: 06-02-82), at roughly the same time (tag group: 06-02-83) or

	CHIPPS ISLAND					CVP	SWP
	Number Recovered	First Day Recovered	Last Day Recovered	Days to First Rec.	Days at Large	First and Last Day Recovered	First and Last Day Recovered
	0	–	–			4/29-5/1	
	2	4/27	5/2		11	5/1	
	1	4/29	4/29		8	5/7	5/12
	3	4/27	5/2	6	11		
	3	4/30	5/5		13		
	2	5/2	5/4		12		
	5	4/30	5/5	8	13		
	57	4/26	5/7	1	12		
	0	–	–			5/1	
	0	–	–			5/7	
	0	–	–				
	0						
	0	–	–			5/7	
	1	5/6	5/6		7		
	1	5/6	5/6	7	7		
	39	5/4	5/12	2	10		

much later (tag group: 06-27-42) than they reached Antioch or Chipps Island (Table 5-6). Fish from the second Durham Ferry group and one tag group from the second Mossdale release were observed during salvage operations but were never recovered at Chipps Island or Antioch. Variability in recovery timing could be an artifact of low recoveries at all recovery locations.

COMPARISON WITH PAST YEARS

Survival between Durham Ferry and Mossdale appeared high in 2003 as in past years. In 2000 through 2003, CDRRs indicated that survival between Durham Ferry and Jersey Point and Mossdale and Jersey Point was not statistically different ($p < 0.05$) (SJRG, 2002 and Figure 5-6), thus we can infer survival between Durham Ferry and Mossdale was generally high in these years. However, low recovery numbers may hinder our ability to detect differences. Continued releases of CWT fish at both sites may

allow estimates of mortality between Durham Ferry and Mossdale if it becomes great enough to detect in the future. If survival between locations is shown to be similar (not statistically different) then groups can be combined. When ocean recovery information becomes available it may also provide a means to assess mortality between Durham Ferry and Mossdale.

Survival from Durham Ferry and Mossdale to Jersey Point was much lower in 2003 than in the past. In 2003 the pooled CDRR from Durham Ferry and Mossdale to Jersey Point was 0.019 (or 0.027 including only the first Durham Ferry release). The pooled CDRR in 2003 was the lowest measured to date, and significantly lower than any pooled CDRR estimated since 2000 (Table 5-7). Even prior to VAMP, with only Chipps Island recoveries, the lowest differential recovery rate with the HORB in place was 0.133 in 1994.

TABLE 5-7
Combined Differential Recovery Rate (CDRR)
and standard errors for CWT salmon
released at Mossdale and Durham Ferry in relation
to those released at Jersey Point

Year	CDRR	Standard Error
1994	0.133	0.099
1997	0.186	0.064
2000	0.187	0.019
2001	0.191	0.014
2002	0.151	0.013
2003	0.019*	0.005

*significantly lower than values in other years

TABLE 5-8
Severity of PKD infection in VAMP fish
between 2000 and 2003. Number positive divided
by the sample size is shown in parentheses.

Year	Percent Infected	Percent with Severe Infection
2000	4 (2/45)	0 (0/45)
2001	100 (34/34)	29 (10/34)
2002	46 (92/201)	1 (2/201)
2003	63 (30/48)	21 (10/48)

TABLE 5-9
Number of days after release of first and last
recovery at Chipps Island and the duration of recovery
(in days) for VAMP released fish in 2000-2003.
Mean duration of recovery period and mean flow in
cubic feet per second (cfs) at Vernalis during the two
upstream Durham Ferry releases is included.

Release Location	Year (San Joaquin Flow Target)			
	2000	2001	2002	2003
Durham Ferry (1)	5-32 (27)	5-11(6)	8-22(14)	6-11(5)
Mossdale (1)	5-16(11)	4-11(7)	7-17(10)	8-13(5)
Jersey Point (1)	2-12(10)	1-7(6)	2-21(19)	1-12(11)
Durham Ferry (2)	5-23(18)	5-13(8)	7-15(8)	–
Mossdale (2)	N/R	5-10(5)	9-19(10)	7(0)
Jersey Point (2)	1-16(15)	1-11(16)	1-19(18)	2-10(8)
Mean Duration (in days)	16.2	7	13.1	6
Mean Flow (in cfs)	6020	4211	3341	3298

N/R = No second release was made
 – = no fish were recovered

The health of the CWT fish in of itself did not appear to account for the low survival observed in 2003. Indices of fish health for VAMP fish used in 2003 were compared with VAMP fish used in earlier years to determine if the incidence and severity of PKD was greater in 2003 than in past years. The severity of PKD infection was determined by examining the kidney tissue. If the parasite was observed the fish was classified as infected. If the parasite had reached a stage where a reaction to the parasite (inflammation) was observed the fish was classified as severely infected.

In 2003, both infection and severe infection were observed in a high percentage of fish used in the VAMP experiments (Table 5-8). However, both the infection and severe infection rates were greater for the VAMP fish released in 2001, when survival through the Delta was estimated to be an order of magnitude higher (0.191 in 2001 versus 0.019 in 2003) (Table 5-8). These data indicate that the PKD infection in and of itself probably did not cause the high mortality of the VAMP fish observed in 2003.

The high level of PKD infection in combination with the lower flows could have increased the mortality of VAMP fish in 2003. PKD in the field likely compromises the fish's performance in many areas (swimming, salt water entry and disease resistance) and could decrease their survival through the Delta (Nichols and Foott, 2002). Nichols and Foott (2002) speculate that differences in the rate of PKD infection could be due to environmental conditions—namely flow and water temperature and that the small number of infected fish in 2000 may have been caused by the lower concentration of the infectious stage of the parasite because of the dilution effect of higher flows. Thus in contrast the lower flows in 2003 may have concentrated the infectious stage of the parasite.

The transit time (the span of time fish were recovered) at Chipps Island for VAMP groups in 2003 was shorter than in past years and may be a reflection of the lower flows and higher incidence of PKD infection. The mean number of days between the first and last day of recovery at Chipps Island for all VAMP groups was less in 2003 (6) compared to past years (Table 5-9).

The number of days until first recovery to Chipps Island appears to be related to San Joaquin River flow. In 2003 the number of days until first recovery was longer (1 to 8 days) when flows were lower (3298 cfs) than in 2000 and 2001 (1 to 5 days and 6020 and 4211 cfs flow respectively). The number of days until first recovery (1 to 9 days) and flow (3341 cfs) (in 2002) was similar to that observed in 2003 (Table 5-9).

In contrast, the number of days until last recovery was sooner in 2003 (7 to 13 days) than in 2002 (ranged from 15 to 22 days after release) and 2000 (12 to 32 days) when PKD infection rate was lower. The number of days until last recovery in 2003 was similar to that observed in 2001 (Table 5-9). Both 2003 and 2001 had the highest percentage of fish infected with PKD (Table 5-8). Differences in the number of days until last recovery may reflect increased mortality over time. Individuals that took longer than the 7 to 13 days to reach the western Delta had higher mortality due to the higher incidence of PKD in 2003 and 2001. It is possible that the combination of the first fish taking longer to reach Chipps Island due to the lower flows and the increased mortality due to the direct or indirect effects of PKD infection for the later migrants may in part explain why survival was so much lower in 2003 than in past years.

Role of Flow and Exports

San Joaquin River flow and flow relative to exports between April and June is correlated to adult escapement in the San Joaquin basin 2 1/2 years later (SJRG 2003). Both relationships are statistically significant ($p < 0.01$) with the ratio of flow to exports accounting for slightly more of the variability in escapement than flow alone ($r^2 = 0.58$ versus $r^2 = 0.42$) (SJRG, 2003). These relationships suggest that adult escapement in the San Joaquin basin is affected by flow in the San Joaquin River and exports from the CVP and SWP during the spring months when juveniles migrate through the river and Delta to the ocean. VAMP was designed to further define the mechanisms behind these relationships by testing how San Joaquin River flows and exports with the HORB affect smolt survival through the Delta.

Survival of juvenile Chinook salmon emigrating from the San Joaquin River system has been evaluated within the framework established by the VAMP experimental design since the spring of 2000. Similar South Delta studies were conducted in 1994 and 1997, prior to the official implementation of VAMP. Fish from the Feather River Hatchery have been used in south Delta studies conducted prior to 1999 (SJRG, 2002).

To assess the relationship between San Joaquin River flows and survival, pooled CDRRs from 2000 through 2003 were plotted. The CDRRs of all Durham Ferry and Mossdale releases within a year were pooled as they were not significantly different from each other at the 95% confidence level. These pooled estimates and their 68% and 95% confidence intervals for 2003 (including the second Durham Ferry release) and the



The high level of PKD infection in combination with the lower flows could have increased the mortality of VAMP fish in 2003. PKD in the field likely compromises the fish's performance in many areas and could decrease their survival through the Delta.

past three years of VAMP releases (2000–2002) are shown in relation to the average San Joaquin River flow at Vernalis for the two, ten-day periods after each release in Figure 5-8. Similar data obtained from releases made at Mossdale in 1994 and 1997 are included but have much wider confidence intervals because fewer recoveries were made since tagged fish were recovered at only one location (Chipps Island) in these years. It is obvious that the 2003 CDRR is much lower than would have been predicted based on past data.

The CDRRs with confidence intervals are also shown in comparison to average Vernalis flow relative to combined CVP and SWP exports for the averaged two, ten-day periods after release for each year (Figure 5-9). Prior to 2003, the relationship of CDRRs to San Joaquin River flow was improved by incorporating exports. The CDRR obtained in 2003 is much lower than what would have been predicted from past data and has weakened the benefit of adding exports into the relationship.

In general, the CDRRs do appear to increase as flows and flows relative to exports increase, but the addition of the 2003 data has resulted in these relationships no longer being statistically significant. As mentioned last year, even when the relationships were statistically significant ($p < 0.10$), confidence intervals indicated data points were not significantly different from each other (SJRG, 2003).

FIGURE 5-8

Combined Differential Recovery Rates (CDRR) and (+/- 1 and 2 standard errors) of CWT smolts released at Durham Ferry and Mossdale relative to Jersey Point releases (with HORB in place) versus San Joaquin River flow at Vernalis in cfs, 2000–2003. 1994 and 1997 releases were made at Mossdale and Jersey Point.

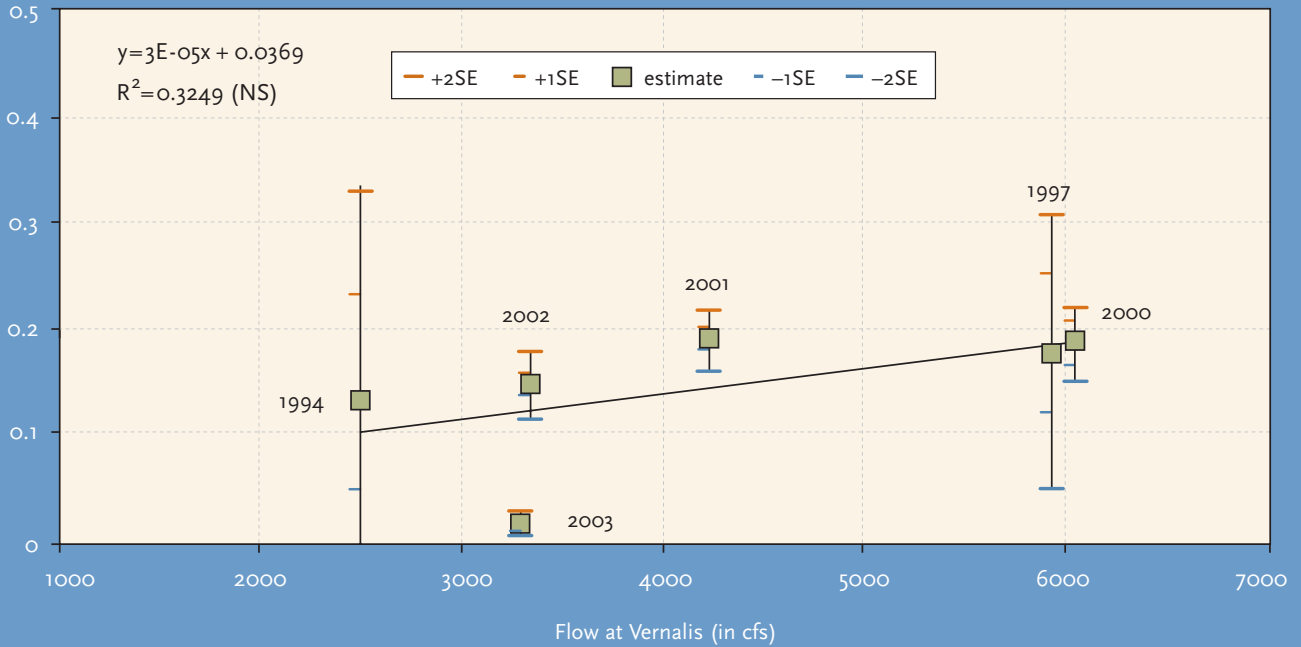
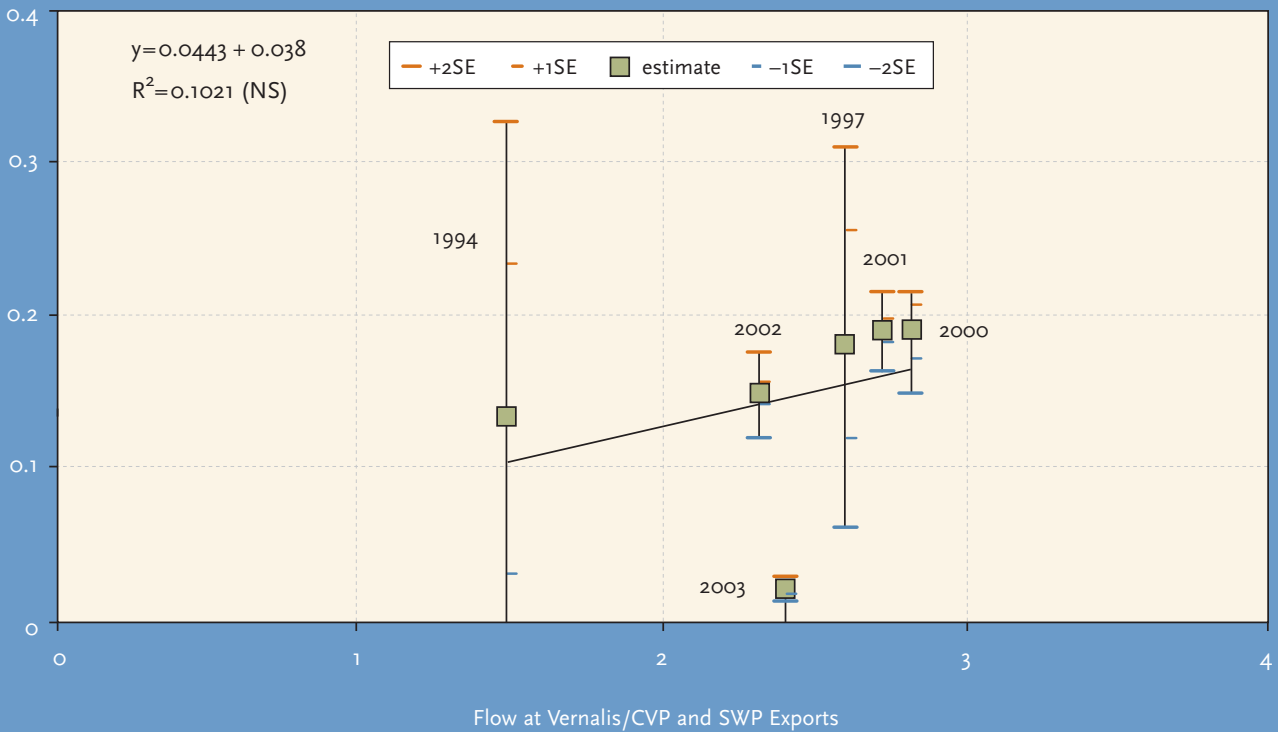

FIGURE 5-9

Combined Differential Recovery Rates (CDRR) and (+/- 1 and 2 standard errors) of CWT smolts released at Durham Ferry and Mossdale relative to Jersey Point releases (with HORB in place) versus the ratio of inflow at Vernalis and CVP and SWP exports, 2000–2003. 1994 and 1997 releases were made at Mossdale and Jersey Point.



It does not appear that flow and exports in 2003 accounted for the low survival observed. As mentioned earlier, San Joaquin River flows and CVP and SWP exports were similar in 2002, but survival was significantly higher in 2002 as shown using the CDRRs and respective confidence intervals (Figure 5-10).

The Role of HORB on Survival

In 2003, the HORB was in place with three culverts operating during the VAMP study period. The barrier is assumed to improve survival based on studies conducted in the 1980s and 1990s (Brandes and McLain, 2001). These studies indicated that smolts released downstream of the Head of Old River survived at about twice the rate of those released upstream. And while those data were not statistically significant, placing a temporary barrier at the Head of Old River appeared to be a management action that would improve survival through the Delta for smolts originating from the San Joaquin basin.

The relationships of absolute survival estimates between Mossdale and Jersey Point and the ratio of San Joaquin River flow at Vernalis to exports with and without the HORB are shown in Figure 5-11. Differential recovery rates (using Chipps Island recoveries only) were not reported since they have not been calculated for past releases without the barrier in place. We assume absolute survival estimates would be comparable to the differential recovery rates. Thus, while comparisons can be made between regression lines, variance around each data point has not been estimated. The two regression lines have been developed based on survival data with and without the HORB. The barrier appears to generally increase survival at any one flow to export ratio, although estimated survival in 2003 was lower than would have been predicted from the model and is similar to levels observed without a barrier in place at the lower inflow to export ratios. In addition there hasn't been much variability in the Vernalis flow to export ratios to test with the barrier in place.

The differences in the target conditions tested in VAMP so far have been small, making it difficult to measure differences in survival due to changes in target conditions. In the six years of measuring survival with the HORB in place, the flow to export ratio has only varied from 1.5 (1994) to 2.9 (2000) (Figures 5-9 and 5-11). The maximum flow to export ratio within the VAMP targets is 4.7, but as of yet has not been tested. The ratios in the relationship between flow to export and adult escapement vary from 0.1 to 1000 (SJR, 2003); a broader representation of how flows relative to exports, during the spring, have varied since 1951.



Placing a temporary barrier at the Head of Old River appeared to be a management action that would improve survival through the Delta for smolts originating from the San Joaquin basin.

Varying designs and changes in the culvert operations of the HORB also make it more difficult to detect significant differences in salmon smolt survival at similar flow to export ratios. During the six years the HORB has been installed (and comparable survival studies conducted) the design and permeability of the HORB have changed. In 1994, the HORB was installed without culverts, while in 1997 the barrier had two open culverts that diverted approximately 300 cfs into upper Old River. In 2000, the HORB had six gated culverts, with two open during the Mossdale and first Durham Ferry releases and four open during the second Durham Ferry release. In 2001 and 2002, six culverts were installed and operated throughout the VAMP test period. It was estimated that approximately 400 cfs from the San Joaquin River moved through the culverts in 2001 and 2002 (Simon Kwan, DWR, personal communication). In 2003, three culverts were open during the studies.

The amount of water flowing through the culverts is based on the head differential between the San Joaquin River and Old River. The amount of water flow moving from the San Joaquin River into Old River would change as flow, stage and the tides change, even if all six culverts remained open for the remaining nine years of the study. These changes in the amount of flow through the culverts and number of culverts operating between years likely affects the entrainment and resulting survival at this point in the river, adding variability in survival from factors other than flow or exports.

FIGURE 5-10

Combined Differential Recovery Rates (CDRR) and (+/- 1 and 2 standard errors) of CWT smolts released at Mossdale and Jersey Point (Mossdale) and Durham Ferry And Jersey Point (Durham Ferry) for the first (1) and second (2) release groups in 2003 (black) and 2002 (red). CDRR were based on the sum of recoveries at Antioch and Chipps Island. Estimates for pooled CDRR's for the two Durham Ferry and Mossdale releases are also provided.

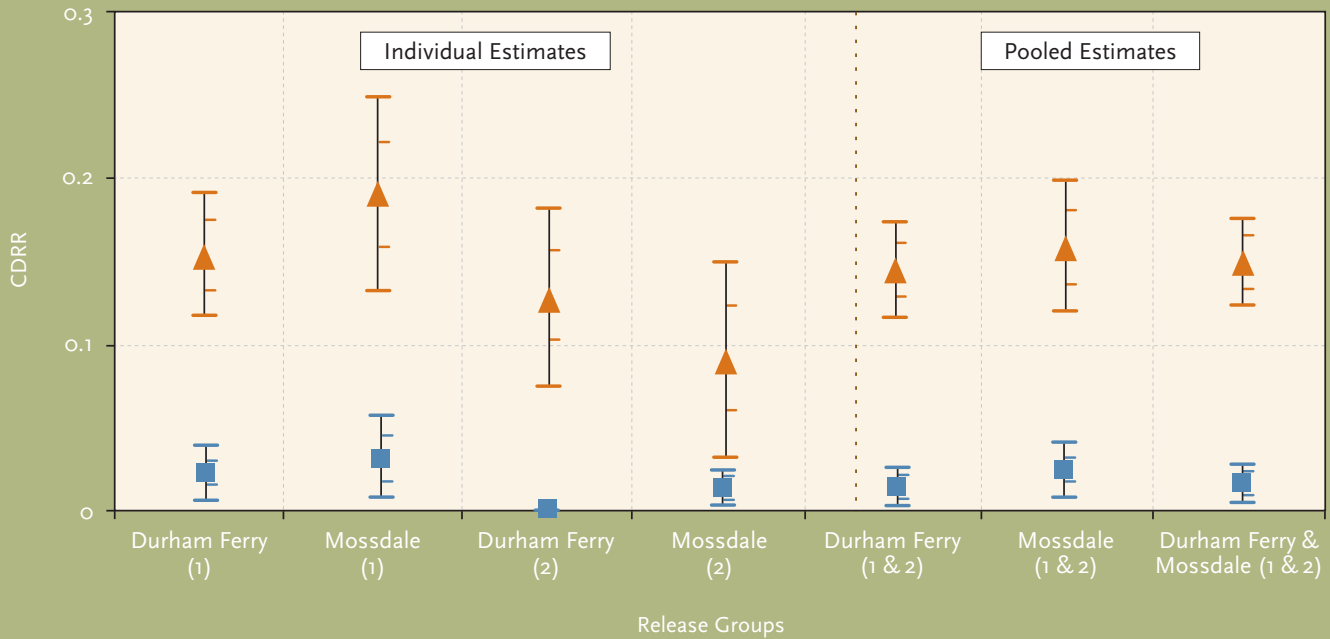
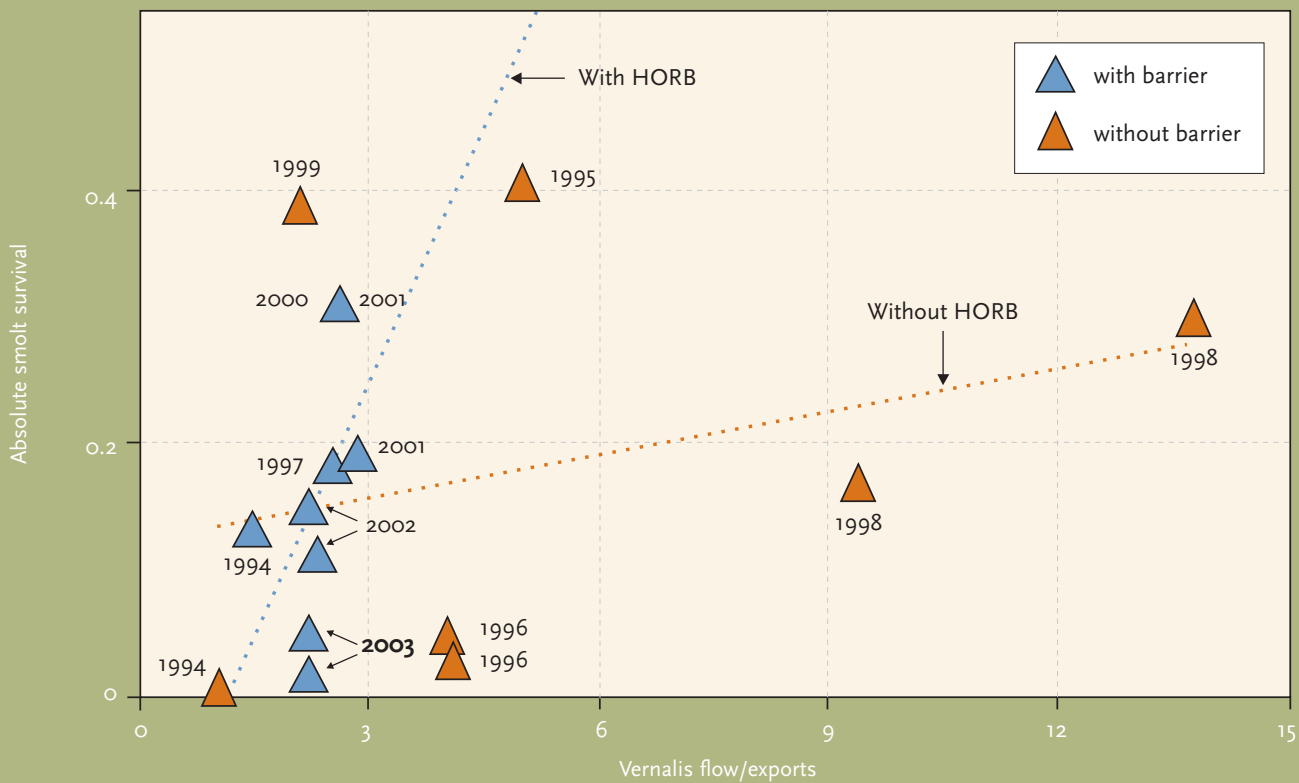

FIGURE 5-11

Estimates of survival of CWT fish released at Mossdale relative to those released at Jersey Point and recovered at Chipps Island with and without a HORB between 1994 and 2003. Similar values were obtained for one 2000 and one 2001 release. HORB can not be installed at Vernalis flow/export levels >4.6



Survival indices of the downstream tributary groups were comparable to indices from the upstream VAMP releases.

The flow through the culverts and the seepage through the rock barrier and would affect the amount of remaining flow left in the San Joaquin River of which the salmon smolts are exposed. Using flow in the San Joaquin River at Vernalis as the estimate of flow the fish are exposed to instead of flow in the San Joaquin River downstream of the HORB adds additional variation to the relationships we are trying to identify and refine. A better estimate of flow to use in these relationships would be the net flow on the San Joaquin River downstream of upper Old River. An estimate of flow in the San Joaquin River downstream of Old River has been made by subtracting the estimated mean daily flow in upper Old River 840 feet downstream of the barrier from the USGS gauged mean daily flow at Vernalis (Chapter 4). In addition in 2003, an Acoustic Doppler Current Profiler (ACDP) was placed in the San Joaquin River downstream of the HORB for the purpose of estimating the flow. This method was deemed the best way to estimate flow at this location. Data from the ACDP are not yet available to use in our analyses. The ACDP data will be compared to that estimated using the mean daily flow in Old River to see how they compare and determine if it is possible to estimate San Joaquin flow downstream of Old River in past years. Future analyses will attempt to use these estimates in comparing smolt survival to San Joaquin River flow.

Comparison with other marked fish released from Merced River Fish Facility

Coded wire tagged salmon from Merced River Fish Facility were released in the San Joaquin River tributaries between April 13 and May 7 as part of independent (complimentary) fishery investigations. Releases were made in the Merced and Stanislaus Rivers at the upper and lower reaches of the rivers below the dams. These studies are reported in more detail in Chapter 6, but are discussed here as they relate to VAMP releases.

Survival indices of the downstream tributary groups to Antioch or Chipps Island would include mortality down the mainstem San Joaquin River as well as through the Delta. While the survival indices of these lower tributary released groups would include some additional river mortality, if main-

stem mortality was low then the indices would be comparable to survival indices of fish released at Durham Ferry and Mossdale as part of VAMP.

Survival indices of the downstream tributary groups were comparable to indices from the upstream VAMP releases. Group survival indices for salmon released in the lower tributaries and recovered at Antioch ranged between 0.002 and 0.032 (Table 5-10). Group survival indices ranged between 0.014 and 0.060 for recoveries made at Chipps Island (Table 5-10). No recoveries were made from the downstream group on the Stanislaus River (Two Rivers) at Chipps Island. Survival indices to Antioch and Chipps Island of VAMP released fish at Mossdale and Durham Ferry ranged from 0.010 to 0.048 (Table 5-4).

These data would indicate that whatever variable affected the survival of upstream released VAMP fish may have affected survival of the lower tributary released fish. It is also likely, that the tributary released fish from Merced River Fish Facility also were infected with PKD.

The survival indices using Antioch and Chipps Island recoveries of releases made in the upper tributaries were also low (Table 5-11) ranging between 0.002 and 0.020. No recoveries were made at Chipps Island for one of the upstream groups released in the Merced River. Again these indices are similar to those obtained for VAMP fish released at Durham Ferry and Mossdale indicating that low survival was not specific to upstream VAMP releases.

Comparison with Sacramento River Delta releases

Average survival indices for three groups of Feather River Hatchery smolts released at Sacramento on April 15, April 30 and May 15, 2003 averaged 0.51. This is within the range and near the average observed in past years (Brandes and McLain, 2001). It appears that whatever factor contributed to the low survival observed for all Durham Ferry and Mossdale CWT fish released from Merced River Fish Facility in 2003 was limited to the San Joaquin basin or Merced River Fish Facility and did not have a similar affect on marked fish released at Sacramento that originated from Feather River Hatchery.

OCEAN RECOVERY INFORMATION FROM PAST YEARS

Ocean recovery data of CWT salmon groups can contribute to a more thorough understanding and evaluation of salmon smolt survival studies. These data can provide another independent estimate of the ratio of recovery rate of a test release group relative to a control release group. Differential recovery rates using ocean recovery information can be compared with

TABLE 5-10
Survival indices at Antioch and Chipps Island of CWT fish released in the lower Merced and Stanislaus Rivers in 2003. Expanded salvage at the CVP and SWP are also included.

Tag Code	Release Site	Date	Number Released	ANTIOCH				
				Number Recovered	Minutes Fished	Percent Sampled	Survival Index	Group Index
Merced River								
06-44-93	Hatfield State Park (lower Merced)		23274	6	2185	0.379	0.049	
06-44-94	Hatfield State Park (lower Merced)		23872	2	5083	0.392	0.015	
06-44-95	Hatfield State Park (lower Merced)		23833	4	2145	0.372	0.032	
Total		4/16/03	70979	12	6103	0.385		0.032
06-45-64	Hatfield State Park (lower Merced)		24545	0	–	–	–	
06-45-65	Hatfield State Park (lower Merced)		24483	0	–	–	–	
06-45-66	Hatfield State Park (lower Merced)		24358	1	590	0.410	0.007	
Total		4/29/03	73386	1	590	0.410		0.002
06-45-46	Hatfield State Park (lower Merced)		22603	0	–	–	–	
06-45-47	Hatfield State Park (lower Merced)		22714	2	1780	0.412	0.015	
06-45-72	Hatfield State Park (lower Merced)		22649	0	–	–	–	
Total		5/7/03	67966	2	1780	0.412		0.005
Stanislaus River								
06-45-70	Two Rivers		26101	1	580	0.403	0.007	
06-45-71	Two Rivers		26632	3	3392	0.393	0.021	
Total		4/27–4/28/03	52733	4	4512	0.392		0.014

TABLE 5-11
Survival indices at Antioch and Chipps Island for coded wire tag releases made in the upper Merced and Stanislaus Rivers in 2003. Expanded salvage at the CVP and SWP are also included.

Tag Code	Release Site	Date	Number Released	ANTIOCH				
				Number Recovered	Minutes Fished	Percent Sampled	Survival Index	Group Index
Merced River								
06-44-89	Merced River Fish Facility		22677	3	2185	0.379	0.025	
06-44-90	Merced River Fish Facility		22816	1	590	0.410	0.008	
06-44-91	Merced River Fish Facility		22946	2	5108	0.394	0.016	
06-44-92	Merced River Fish Facility		21725	0	–	–	–	
Total		4/13/03	90164	6	6123	0.387		0.012
06-44-96	Merced River Fish Facility		24232	0	–	–	–	
06-44-97	Merced River Fish Facility		23869	0	–	–	–	
06-44-98	Merced River Fish Facility		23757	1	572	0.397	0.008	
06-44-99	Merced River Fish Facility		23950	0	–	–	–	
Total		4/25/03	95808	1	572	0.397		0.002
06-27-77	Merced River Fish Facility		23590	0	–	–	–	
06-27-78	Merced River Fish Facility		23862	0	–	–	–	
06-44-49	Merced River Fish Facility		23512	1	487	0.338	0.009	
06-44-50	Merced River Fish Facility		24330	0	–	–	–	
Total		5/4/03	95294	1	487	0.338		0.002
Stanislaus River								
06-45-67	Knight's Ferry		25599	1	600	0.417	0.007	
06-45-68	Knight's Ferry		26226	0	–	–	–	
06-45-69	Knight's Ferry		26136	1	560	0.389	0.007	
Total		4/25/03	77961	2	7967	0.395		0.005

	CHIPPS ISLAND					Expanded Salvage Numbers	
	Number Recovered	Minutes Fished	Percent Sampled	Survival Index	Group Index	CVP	SWP
	4	1200	0.278	0.080		12	18
	1	400	0.278	0.020		12	9
	4	4379	0.276	0.079		12	0
	9	4779	0.277		0.060		
	0	-	-	-		0	0
	2	1460	0.253	0.042		0	0
	0	-	-	-		0	6
	2	1460	0.253		0.014		
	1	400	0.278	0.021		0	0
	0	-	-	-		0	0
	2	400	0.278	0.041		0	0
	3	1200	0.278		0.021		
	0	-	-	-		0	0
	0	-	-	-		0	0
	0				-		

These data would indicate that whatever variable affected the survival of upstream released VAMP fish may have affected survival of the lower tributary released fish. It is also likely, that fish released from Merced River Fish Facility into tributaries also were infected with PKD.

	CHIPPS ISLAND					Expanded Salvage Numbers	
	Number Recovered	Minutes Fished	Percent Sampled	Survival Index	Group Index	CVP	SWP
	1	400	0.278	0.021		24	6
	1	400	0.278	0.021		0	0
	0	-	-	-		0	6
	1	400	0.278	0.022		0	6
	3	2800	0.278		0.016		
	0	-	-	-		0	0
	0	-	-	-		0	0
	0	-	-	-		0	0
	0	-	-	-		12	0
	0				-		
	1	400	0.278	0.020		0	0
	0	-	-	-		12	0
	1	400	0.278	0.020		12	0
	2	1600	0.278	0.038		0	6
	4	2387	0.276		0.020		
	0	-	-	-		0	0
	1	400	0.278	0.018		0	0
	0	-	-	-		0	0
	1	400	0.278		0.006		



One of the VAMP objectives is to provide improved conditions to increase the survival of juvenile Chinook salmon smolts produced in the San Joaquin River tributaries during their downstream migration through the lower river and Delta.

absolute survival estimates and the differential or combined differential recovery rates of juvenile salmon recovered at Chipps Island or Chipps Island and Antioch, respectively. The ocean harvest data may be particularly reliable due to the number of CWT recoveries and the extended recovery period.

Adult recovery data are gathered from commercial and sport ocean harvest checked at various ports by DFG. The Pacific States Marine Fisheries Commission database of ocean harvest CWT data was the source of recoveries through 2002. The ocean CWT recovery data accumulate over a one to four year period after the year a study release is made as nearly all given year-classes of salmon have been either harvested or spawned by age five. Consequently, these data are essentially complete for releases made through 1998 and partially available for CWT releases made from 1999 to 2001.

Differential recovery rates based on ocean recoveries, Chipps Island recoveries or combined differential recovery rates using Antioch and Chipps Island recoveries for salmon produced at the Merced River Hatchery are shown in Table 5-12. Absolute survival estimates based on Chipps Island and Antioch survival indices are also included. The earlier releases were made as part of south Delta survival evaluations (1996–1999) with the later releases associated with VAMP (2000–2001). Releases have been made at several locations: Dos Reis (on the San Joaquin River downstream of the upper Old River junction),

Mossdale, Durham Ferry, and Jersey Point. The Chipps Island and Antioch survival estimates and combined differential (Antioch and Chipps Island recoveries summed) or differential recovery rates (Chipps Island recoveries only) are graphed in relation to the differential recovery rate using the ocean recovery information in Figure 5-12.

Results of this comparative analysis of survival estimates and differential recovery rates for Chinook salmon produced in the Merced River Hatchery show: (1) to date, there is general, but variable, agreement between survival estimates and differential recovery rates based on juvenile CWT salmon recoveries in Chipps Island and Antioch trawling and adult recoveries from the ocean fishery, (2) absolute survival estimates using Chipps Island or Antioch recoveries were either lower or similar to estimates based on ocean recoveries, with the exception of first releases in 2001, and (3) additional comparisons need to be made, as more data becomes available from VAMP releases for recoveries at Antioch, Chipps Island, and the ocean fishery. Information on survival of juvenile salmon and the contribution to the adult salmon population will be essential to evaluate the biological benefits of changes in flow and export rates under VAMP.

SAN JOAQUIN RIVER SALMON PROTECTION

One of the VAMP objectives is to provide improved conditions to increase the survival of juvenile Chinook salmon smolts produced in the San Joaquin River tributaries during their downstream migration through the lower river and Delta. It is assumed that these actions to improve conditions for the juveniles will translate into greater adult abundance and escapement in future years, especially during low flows, when corresponding adult escapement (2 ½ years later) has been extremely low (SJRJ, 2003).

To determine if VAMP in 2003 was successful in targeting the migration period of naturally produced juvenile salmon, catches of unmarked salmon at Mossdale and in salvage at the CVP and SWP facilities were compared prior to and during the VAMP period.

Unmarked Salmon Recovered at Mossdale

The time period for VAMP (April 15 to May 15) was chosen based on historical data that indicated a high percentage of the juvenile salmon emigrating from the San Joaquin tributaries passed into the Delta at Mossdale during that time. The average catch per minute per day of unmarked juvenile salmon caught in kodiak trawling at Mossdale between March 15 and June 30, 2003 is shown in Figure 5-13. Unmarked salmon do not have an adipose clip and could be unmarked fish from the Merced River

FIGURE 5-12

Comparison of Antioch and Chipps Island survival estimates and differential or combined differential recovery rates compared to differential ocean recovery rates. The one to one line is also included.

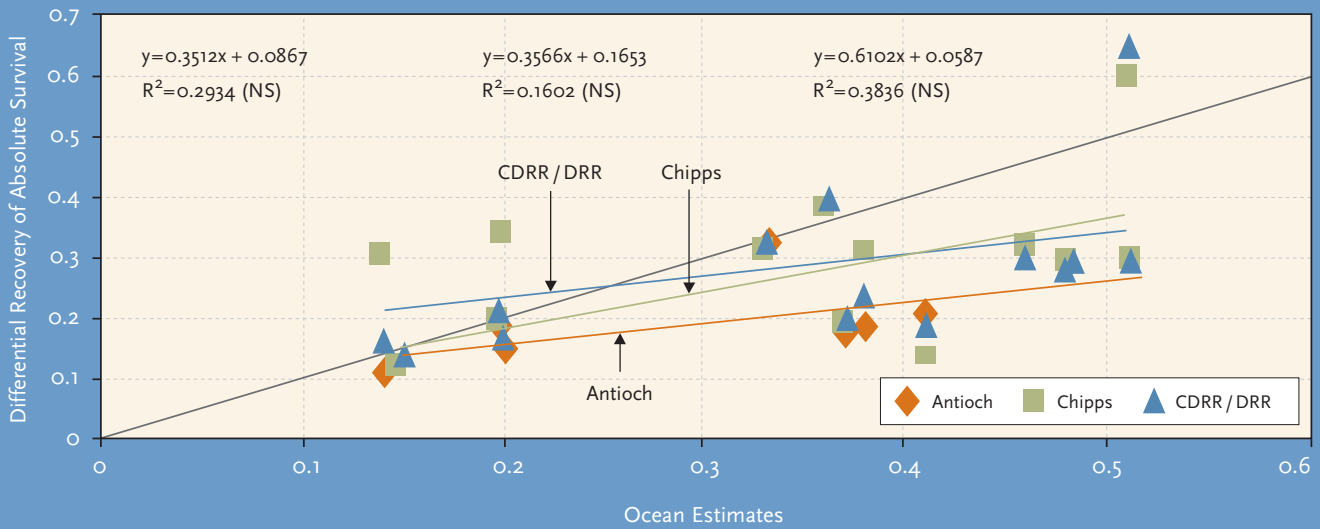

FIGURE 5-13

Standardized catch per cubic meter of all unmarked juvenile Chinook salmon in the Mossdale Kodiak trawl, March 15, 2003 through June 30, 2003.

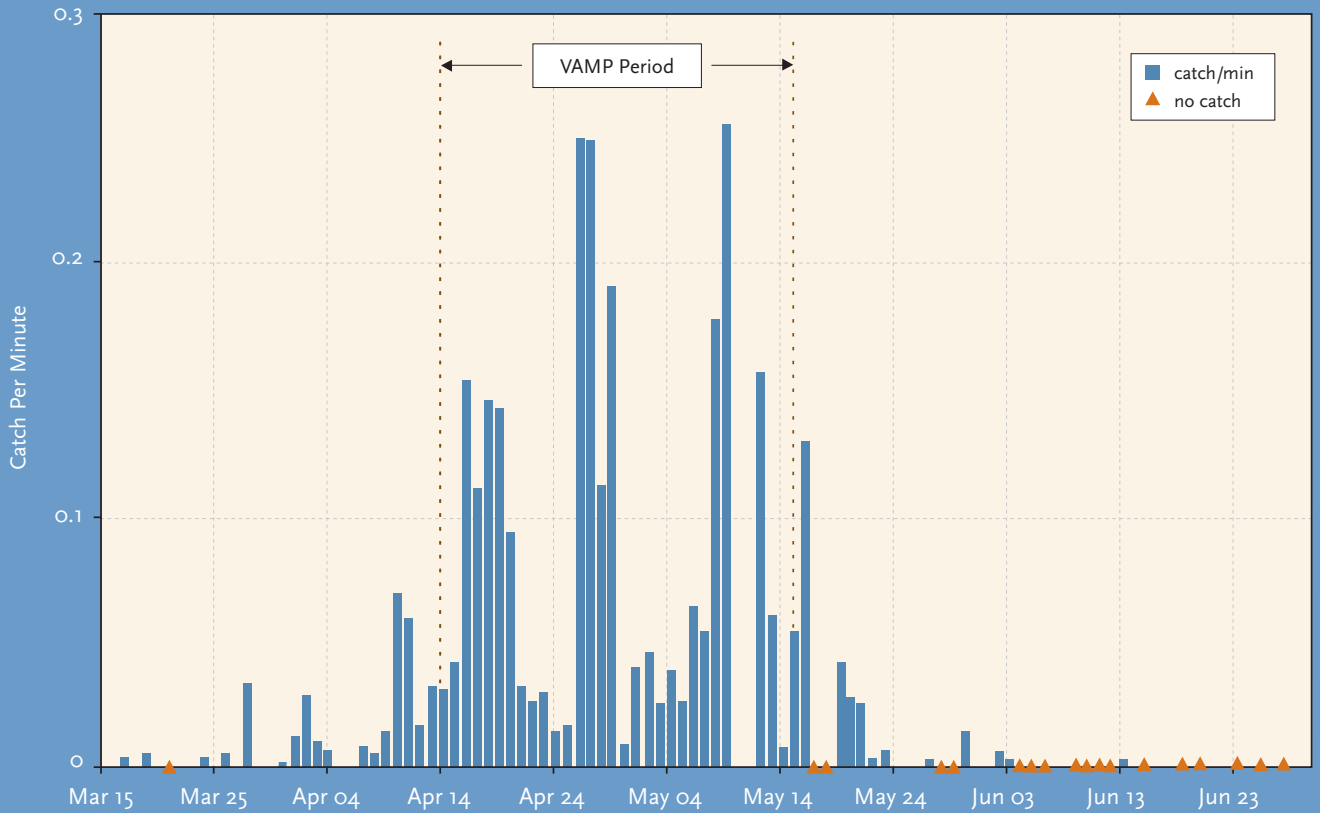

TABLE 5-12
Survival indices based on Chipps Island, Antioch, and ocean recoveries of Merced River Fish Facility salmon released as part of South Delta studies between 1996 and 2001.

Release Year	San Joaquin River (Merced River origin) Tag No.	Release Number	Release Site	Release Date	Chipps Island Recovs.	Antioch Recovs.	Expanded Adult Ocean Recovs. (age 1+ to 4+) Total	Chipps Island	Antioch	DRR or CDRR	Ocean Catch
								Absolute Survival Estimates		Differential Recovery Rates	
1996	H61110412	25,633	Dos Reis	1 May 96	2		3				
	H61110413	28,192	Dos Reis	1 May 96	3		37				
	H61110414	18,533	Dos Reis	1 May 96	1		8				
	H61110415	36,037	Dos Reis	1 May 96	5		10				
	H61110501	53,337	Jersey Pt	3 May 96	39		187				
	Effective Release	107,961	Dos Reis		11		58	0.12		0.14	0.15
Effective Release	51,737	Jersey Pt		39		187					
1997	H62545	50,695	Dos Reis	29 Apr 97	9		183				
	H62546	55,315	Dos Reis	29 Apr 97	7		167				
	H62547	51,588	Jersey Pt	2 May 97	27		355				
	Effective Release	106,010	Dos Reis		16		350	0.29		0.29	0.48
	Effective Release	51,588	Jersey Pt		27		355				
	H62548	46,728	Dos Reis	8 May 97	5		91	0.30		0.28	0.48
H62549	47,254	Jersey Pt	12 May 97	18		192					
1998	61110809	26,465	Mossdale	16 Apr 98	25		61				
	61110810	25,264	Mossdale	16 Apr 98	31		40				
	61110811	25,926	Mossdale	16 Apr 98	32		58				
	61110806	26,215	Dos Reis	17 Apr 98	33		47				
	61110807	26,366	Dos Reis	17 Apr 98	23		35				
	61110808	24,792	Dos Reis	17 Apr 98	34		61				
	61110812	24,598	Jersey Pt	20 Apr 98	87		110				
	61110813	25,673	Jersey Pt	20 Apr 98	100		91				
	Effective Release	77,655	Mossdale		88		159	0.30		0.30	0.51
Effective Release	77,373	Dos Reis		90		143	0.32		0.31	0.46	
Effective Release	50,271	Jersey Pt		187		201					
1999	062642	24,715	Mossdale	19 Apr 99	8		128				
	062643	24,725	Mossdale	19 Apr 99	15		134				
	062644	25,433	Mossdale	19 Apr 99	13		130				
	062645	25,014	Dos Reis	19 Apr 99	20		151				
	062646	24,841	Dos Reis	19 Apr 99	19		218				
	0601110815	24,927	Jersey Pt	21 Apr 99	34		333				
	062647	24,193	Jersey Pt	21 Apr 99	25		379				
	Effective Release	74,873	Mossdale		36		392	0.38		0.40	0.36
	Effective Release	49,855	Dos Reis		39		369	0.60		0.65	0.51
Effective Release	49,120	Jersey Pt		59		712					

TABLE 5-12 (continued)
Survival indices based on Chipps Island, Antioch, and ocean recoveries of Merced River Fish Facility salmon released as part of South Delta studies between 1996 and 2001.

Release Year	San Joaquin River (Merced River origin) Tag No.	Release Number	Release Site	Release Date	Chipps Island Recovs.	Antioch Recovs.	Expanded Adult Ocean Recovs. (age 1+ to 4+) Total	Chipps Island	Antioch	DRR or CDRR	Ocean Catch
								Absolute Survival Estimates		Differential Recovery Rates	
2000	06-45-63	24,457	Durham Ferry	17 Apr 00	11	11	235				
	06-04-01	23,529	Durham Ferry	17 Apr 00	7	6	190				
	06-04-02	24,177	Durham Ferry	17 Apr 00	10	10	225				
	06-44-01	23,465	Mossdale	18 Apr 00	9	14	198				
	06-44-02	22,784	Mossdale	18 Apr 00	9	16	159				
	06-44-03	25,527	Jersey Pt	20 Apr 00	24	50	592				
	06-44-04	25,824	Jersey Pt	20 Apr 00	41	47	617				
	Effective Release	72,163	Durham Ferry		28	27	650	0.31	0.19	0.24	0.38
	Effective Release	46,249	Mossdale		18	30	357	0.31	0.33	0.33	0.33
	Effective Release	51,351	Jersey Pt		65	97	1209				
2000	601060914	23,698	Durham Ferry	28 Apr 00	7	8	43				
	601060915	26,805	Durham Ferry	28 Apr 00	5	15	36				
	0601110814	23,889	Durham Ferry	28 Apr 00	10	8	70				
	0601061001	25,572	Jersey Pt	1 May 00	48	76	300				
	0601061002	24,661	Jersey Pt	1 May 00	30	76	215				
	Effective Release	74,392	Durham Ferry		22	31	149	0.19	0.14	0.16	0.20
	Effective Release	50,233	Jersey Pt		78	152	515				
2001	06-44-29	23,354	Durham Ferry	30 Apr 01	14	28	4				
	06-44-30	22,837	Durham Ferry	30 Apr 01	22	30	26				
	06-44-31	22,491	Durham Ferry	30 Apr 01	17	18	4				
	06-44-32	23,000	Mossdale	1 May 01	17	18	16				
	06-44-33	22,177	Mossdale	1 May 01	14	15	0				
	06-44-34	24,443	Jersey Pt	4 May 01	50	156	50				
	06-44-35	24,992	Jersey Pt	4 May 01	61	173	72				
	Effective Release	68,682	Durham Ferry		53	76	34	0.34	0.17	0.21	0.20
	Effective Release	45,177	Mossdale		31	33	16	0.31	0.11	0.16	0.14
	Effective Release	49,435	Jersey Pt		111	329	122				
2001	06-44-36	24,025	Durham Ferry	7 May 01	2	8	5				
	06-44-37	24,029	Durham Ferry	7 May 01	5	11	9				
	06-44-38	24,177	Durham Ferry	7 May 01	2	10	4				
	06-44-39	23,878	Mossdale	8 May 01	4	8	11				
	06-44-40	25,308	Mossdale	8 May 01	4	11	0				
	06-44-41	25,909	Jersey Pt	11 May 01	17	43	18				
	06-44-42	25,465	Jersey Pt	11 May 01	27	53	13				
	Effective Release	72,231	Durham Ferry		9	29	18	0.13	0.20	0.19	0.41
	Effective Release	49,186	Mossdale		8	19	11	0.19	0.18	0.20	0.37
	Effective Release	51,374	Jersey Pt		44	96	31				

Note: Ocean recoveries are based on data through 2002

FIGURE 5-14

Individual fork lengths (mm) of all unmarked juvenile Chinook salmon in the Mossdale Kodiak trawl, March 15, 2003 through June 30, 2003.

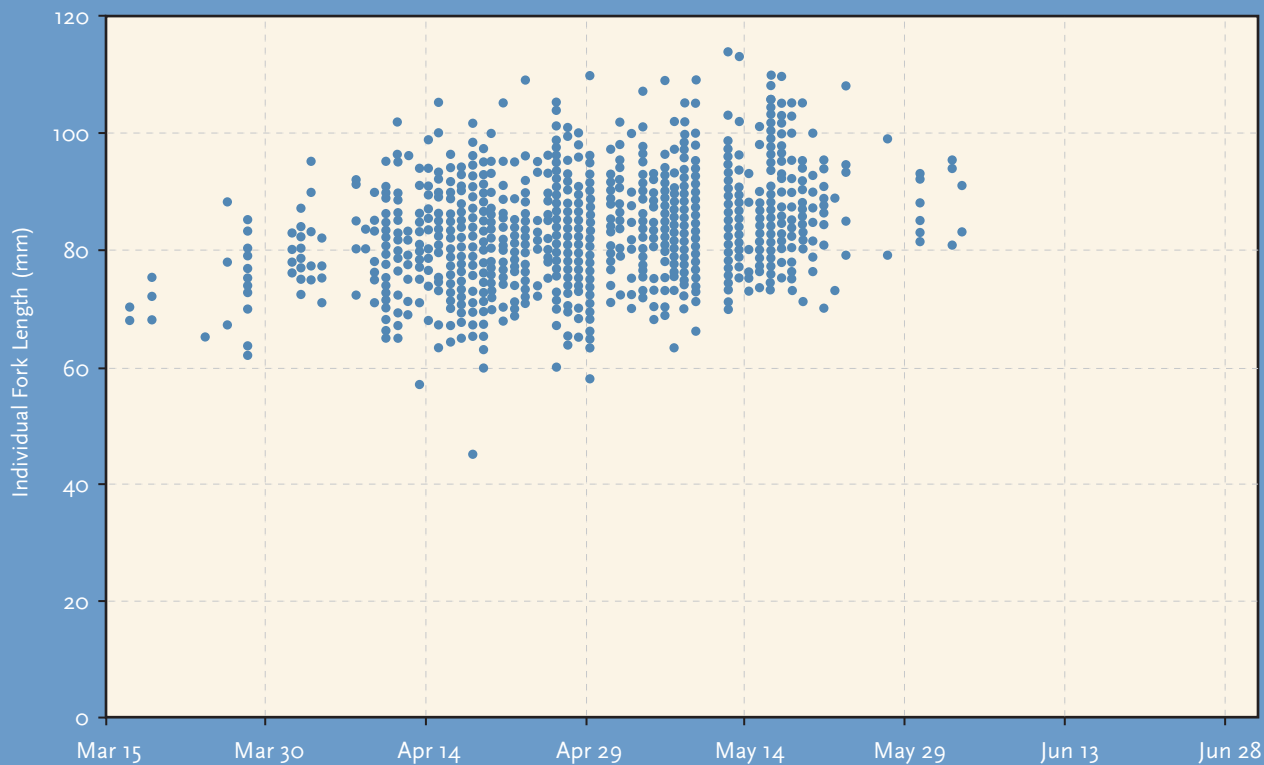
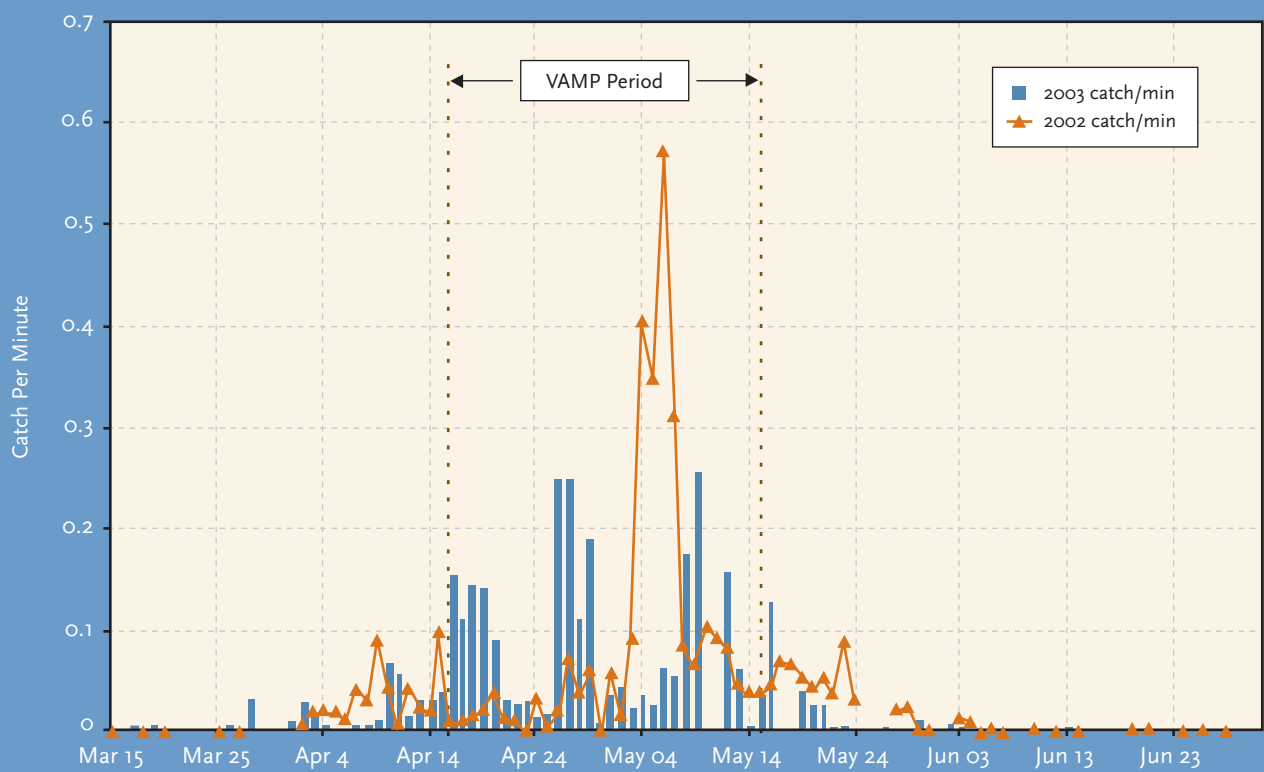

FIGURE 5-15

Standardized catch per minute of all unmarked juvenile Chinook salmon in the Mossdale Kodiak trawl, March 15 through June 30, 2002 and 2003.



Fish Facility or juveniles from natural spawning. Approximately 80% of the unmarked catch that passed Mossdale between March 15 and June 30 passed during the VAMP period: April 15 to May 15. The size of the juvenile salmon migrating past Mossdale between March 15 and June 30, 2003 is shown in Figure 5-14.

The pattern of unmarked juvenile salmon caught at Mossdale in 2003 was different than that observed in 2002, and did not obviously show that the number of fish passing Mossdale was less in 2003 than it was in 2002 (Figure 5-15). The peak in early May of 2002 was greater than any peak observed in 2003, but catches in 2003 were greater than 2002 during other times.

Salmon Salvage and Losses at Delta Export Pumps

Fish salvage operations at the CVP and SWP export facilities capture unmarked salmon for transport by tanker truck and release them downstream in the western Sacramento–San Joaquin Delta. The untagged salmon are either naturally produced or untagged hatchery salmon, potentially from any source in the Central Valley. It is not certain which unmarked salmon recovered are of San Joaquin basin origin, although the timing of salvage and fish size can be compared with Mossdale trawl data and CWT recovery data for Merced River Fish Facility smolts at the facilities to provide some general indications.

The salvage at the facilities is based on expansions from sub-samples taken throughout the day. Four to five salmon are estimated to be lost per salvaged salmon in the SWP Clifton Court Forebay based on high predation rates. The CVP pumps divert directly from the Old River channel and the loss estimates range from about 50 to 80% of the number salvaged, or about six to eight times less per salvaged salmon than for the SWP. The loss estimates do not include any indirect mortality in the Delta due to water export operations, additional mortality associated with trucking and handling, or post-release predation. Salvage density of salmon is the number of salvaged salmon per acre-foot of water pumped. The California Department of Water Resources maintains a database of daily, weekly, and monthly salvage data. [📄](#)

The number and density of juvenile salmon that migrated through the system, the placement of the HORB, and the amount of water pumped by each facility are some of the factors that influence the number of juvenile salmon salvaged and lost. Density is the best indicator of when concentrations of juvenile salmon are most susceptible to the export facilities and salvage system.

The number and density of juvenile salmon that migrated through the system, the placement of the HORB, and the amount of water pumped by each facility are some of the factors that influence the number of juvenile salmon salvaged and lost.

The weekly data covering the period of April 13 to May 17 encompassed the 2003 VAMP period. A review of weekly data for March through May indicates that the highest salvage and losses occurred during the three weeks prior to VAMP (period of March 23 to April 12), with the exception of the highest CVP losses being recorded in the second VAMP week, April 20 to 26 (Figures 5-16 and 5-17). Combined CVP and SWP weekly export rates during those three weeks preceding VAMP averaged 7,500–10,900 cfs (Figure 5-18). Salmon density was highest in the second week of the VAMP period at both the CVP and SWP facilities, and continued to be relatively high during the VAMP period (Figure 5-19), indicating the VAMP export reductions were in place when the density of salmon was the highest. Based on comparisons with Mossdale data in Figure 5-13, it appears that most of the salmon salvaged in early April may not have been of San Joaquin basin origin. Reducing exports earlier in April may provide better conditions for juvenile spring-, winter-, and fall- run Chinook salmon migrating through the Delta from the Sacramento River basin.

The size distribution of unmarked salmon during April and May in the Mossdale trawl (Figure 5-14) is a subset of the size distribution of those salvaged at the fish facilities (Figure 5-20: Source E. Chappell, DWR). In 2003, the fish facilities salvaged some juvenile salmon between March 15 and early May that were larger (winter run sized) than any observed at Mossdale.

Results of these analyses showed that the 2003 VAMP test period coincided with much of the peak period of San Joaquin River salmon smolt emigration. Reductions in SWP and CVP exports and increased San Joaquin River flow likely provided improved conditions for salmon survival, although starting the VAMP period two to three weeks earlier may have had substantial benefits for other salmon races and stocks.

FIGURE 5-16

2003 SWP salmon salvage and loss.

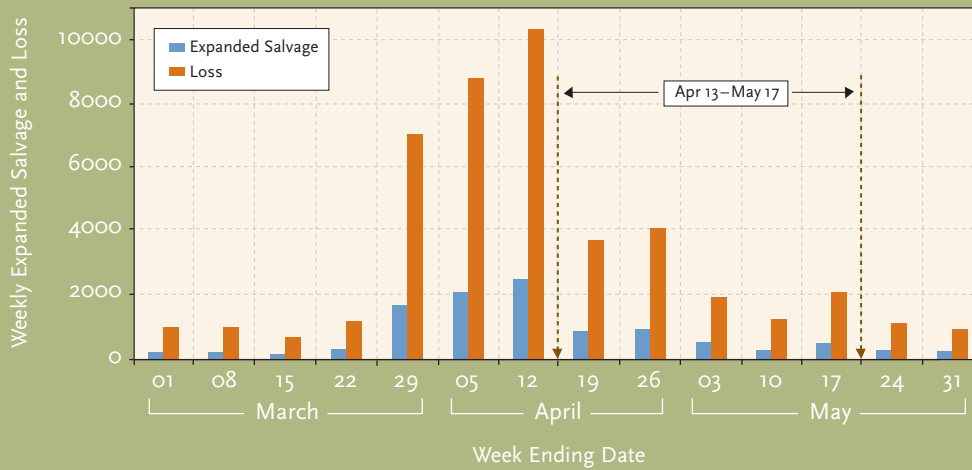
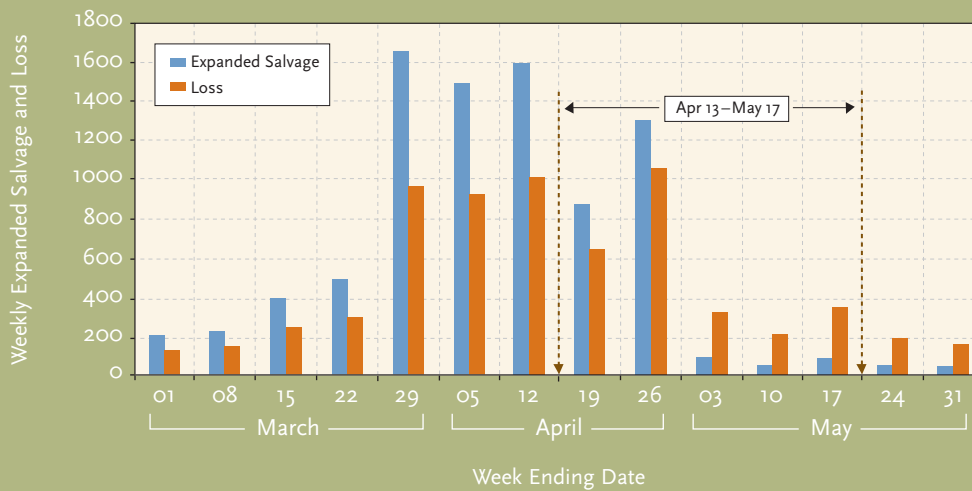

FIGURE 5-17

2003 CVP salmon salvage and loss.



SUMMARY AND RECOMMENDATIONS

The survival estimates and CDRRs measured in 2003 were low compared to past years. It is unclear why survival in 2003 was so low but it does not seem to be directly related to San Joaquin River flow, CVP and SWP exports or water temperature. The hatchery fish were infected with the parasite that causes PKD. Fish have been infected in past VAMP study years and it does not appear that the incidence of PKD was actually higher in 2003. However, the combination of the lower flows and PKD infection may have affected the mortality of the VAMP fish in 2003 resulting in shorter transit duration and higher mortality relative to past VAMP releases.

Some rain occurred during the studies, which was somewhat unusual, and possibly agricultural and/or urban run-off from the storm caused mortality, but a toxic event due to storm-water run-off should be episodic and not be a long-term event affecting all the releases made at Merced River Fish Facility over a three week period. The high and similar mortality of the tributary CWT groups released from Merced River Fish Facility indicates that whatever increased the mortality of the VAMP fish was some condition that was common to the Merced River Fish Facility (with the exception of the Jersey Point releases) and lasted for several weeks. This condition also appeared to be restricted to the Delta or differences in the survival indices for the upstream

FIGURE 5-18

2003 weekly SWP/CVP export rates and Vernalis flow.

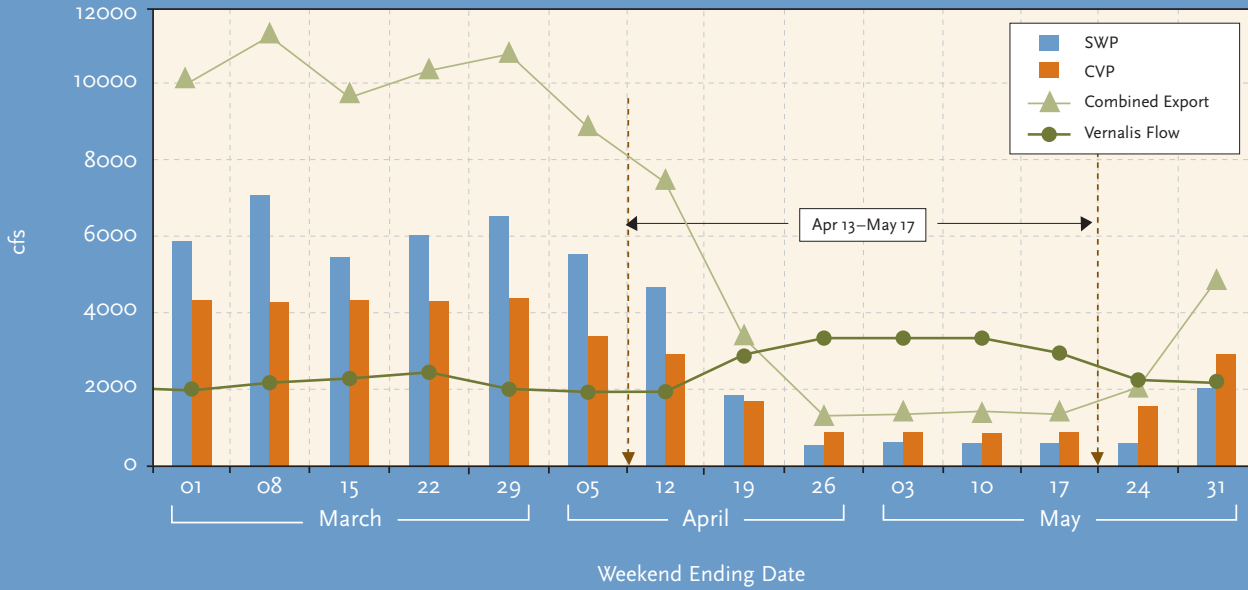

FIGURE 5-19

2003 SWP/CVP expanded salmon salvage density.

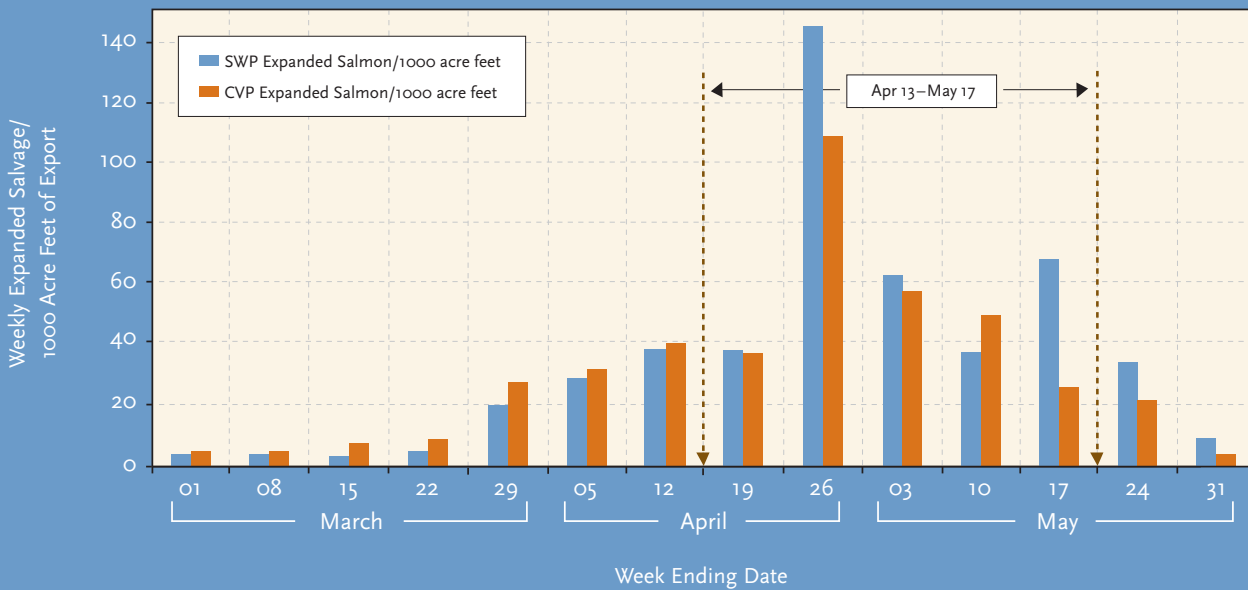
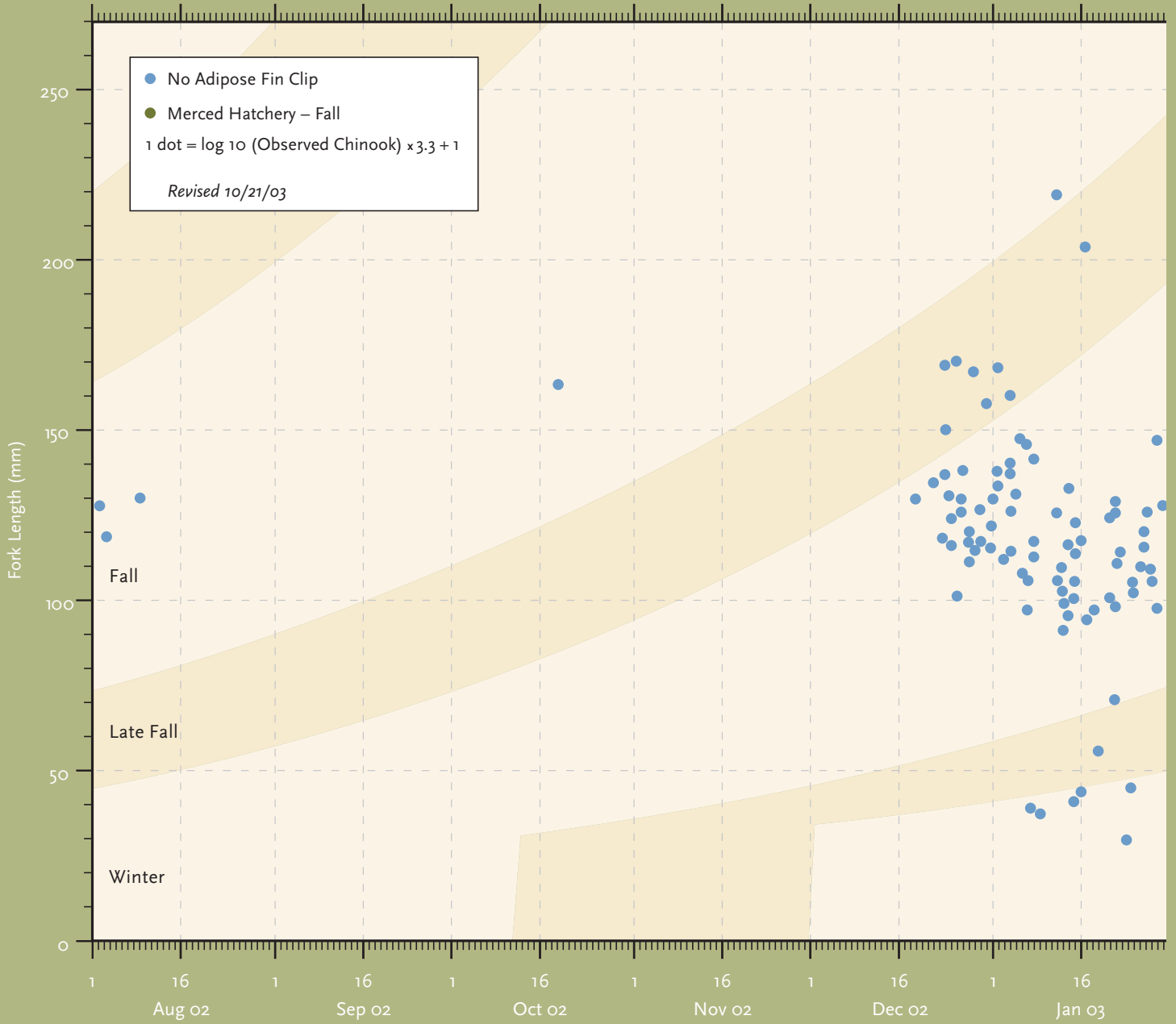
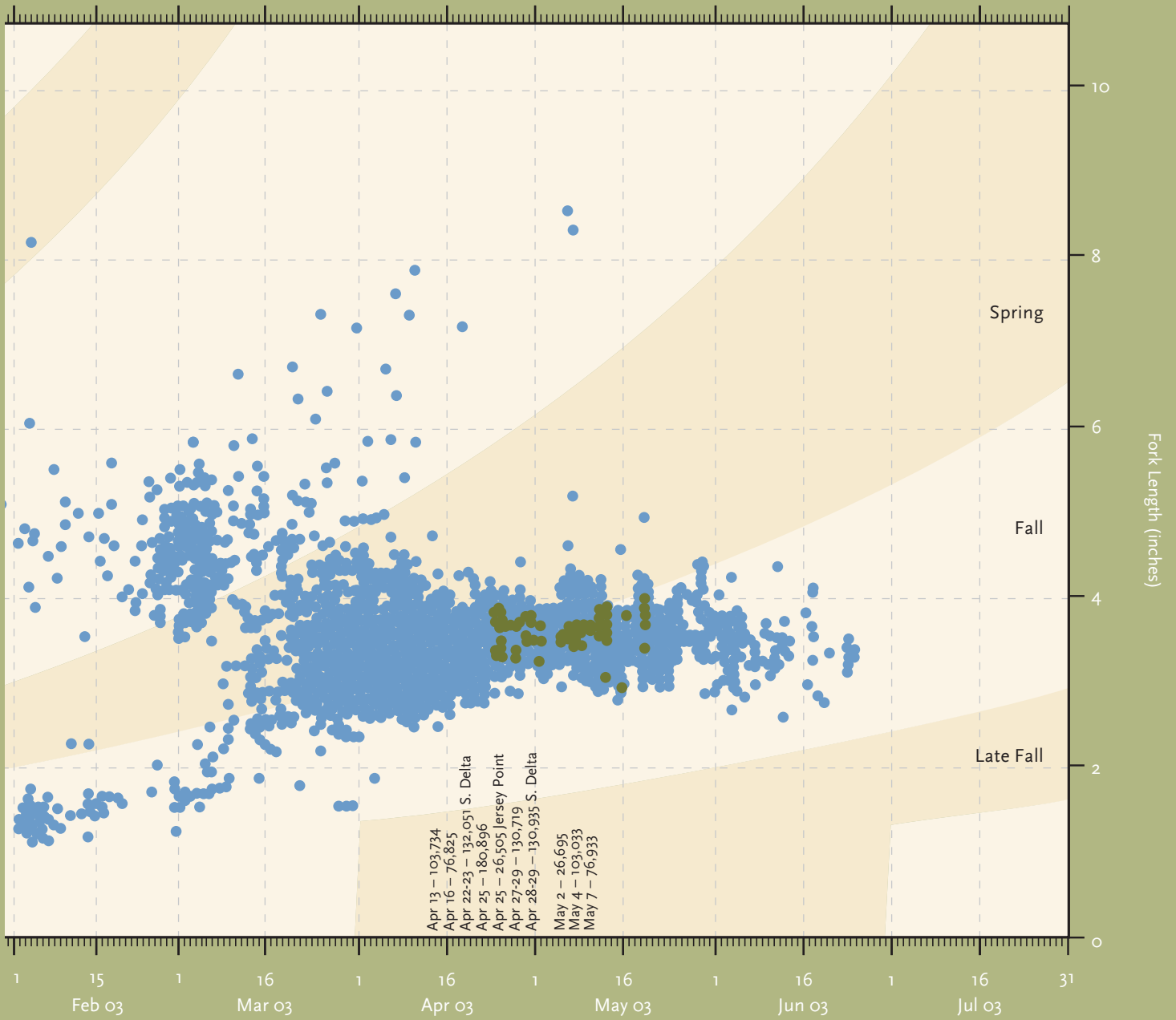

FIGURE 5-20

Observed Chinook Salvage at the SWP & CVP Delta Fish Facilities 8/1/02 through 7/31/03







and downstream tributary releases would have been greater. While the causes are unclear, it would appear the VAMP data in 2003 are outliers and repeating the study in future years will determine if this anomaly is limited to 2003 or is a change in overall conditions.

Even without the 2003 data, there have been several impediments to defining and refining the relationships between smolt survival and San Joaquin River flow and CVP and SWP exports. These impediments have been discussed in this and previous VAMP reports. The different permeability of the HORB and not having estimates of flow in the San Joaquin River downstream of the barrier add noise to our estimates of flow. In addition, using diseased hatchery fish in VAMP experiments adds a potential bias to our estimates of survival, even though PKD is also present in wild stocks (Ken Nichols, USFWS internal memo, 12/6/02). Measuring survival within the narrowly defined flow and export VAMP targets further exacerbates the problem of noise in the variables of interest. The level of precision of our survival estimates and the noise in flow measurements limits our ability to precisely define the relationship of survival to flow and exports. Yearly, pooled estimates are now based on releases of 300,000 to 400,000 fish with two recovery locations, sampling roughly seven to ten hours per day, yet recoveries have not been great enough to statistically differentiate between survival estimates measured at VAMP target flow and exports levels obtained to date. Differences in survival may be occurring but our ability to detect them is limited.

To address this dilemma, future studies should prioritize measuring survival at the highest VAMP target flow and lowest export levels. Flows of 7000 cfs and exports of 1500 cfs would achieve the highest inflow to export ratio (4.7) within the VAMP design and provide a new target to test. Based on information to date, the higher flow would be probably increase survival and may lessen any effects or infection rate of PKD. The higher survival should increase recovery numbers such that CDRRs



Even without the 2003 data, there have been several impediments to defining and refining the relationships between smolt survival and San Joaquin River flow and CVP and SWP exports.

and confidence intervals may show statistical differences when compared to previously obtained CDRRs. It is uncertain how such a condition can be prescribed, independent of the hydrology, within the existing San Joaquin River Agreement, but the idea should be explored by the VAMP Management Team.

Further confidence in defining and refining the relationship of smolt survival to flow and exports could be obtained by increasing the length of the study. The fourth year of VAMP was completed in 2003 with eight years remaining in the study. Additional replication can resolve uncertainty when variation is high.

Continued assessment of past data is also recommended such that other methodologies or criteria for determining statistical differences between groups may be developed.

CHAPTER 6

Complimentary Studies Related to the VAMP

Throughout 2003 several fishery studies were conducted that were considered to be important to the overall understanding of the salmon life cycle and survival in the San Joaquin River. These are presented below to provide the reader with summary information on each study. More information can be obtained from each study manager or report author.

SURVIVAL ESTIMATES FOR CWT RELEASES MADE IN THE SAN JOAQUIN TRIBUTARIES

contributed by Pat Brandes, U.S. Fish and Wildlife Service

As discussed previously, CWT salmon releases were made in the San Joaquin River tributaries between April 13 and May 7 as part of independent (complimentary) fishery investigations. Three sets of releases were made in the upper Merced River (Merced River Fish Facility) and lower Merced River (Hatfield State Park). One additional set of CWT salmon were also released in the upper (Knights Ferry) and lower (Two Rivers) Stanislaus River.

Group survival indices for salmon released in the tributaries and recovered at Antioch ranged between 0.002 and 0.032 (Tables 5-10 and Table 5-11). Group survival indices ranged between 0.014 and 0.060 to Chipps Island (Tables 5-10 and 5-11). These indices were similar to those in 2002, but much lower than in 2001, where indices ranged from 0.03 to 0.20. Vernalis flow targets were lower in 2002 and 2003 than in 2001 (3300 cfs vs. 4200 cfs). The tributary flows were also likely lower. No recoveries at Chipps Island were made for the second upper Merced and lower Stanislaus releases.

Comparison of survival indices of the upstream tributary groups relative to the downstream groups provides an estimate of survival through the tributaries. The survival estimates through the tributaries are provided in Table 6-1. Survival through the Merced River ranged between 0.26 and 0.96, although there

were instances where no recoveries were made at Chipps Island. Survival through the Stanislaus was estimated at 0.34 using Antioch recoveries. No recoveries were made of the lower Stanislaus group at Chipps Island. It appeared survival through the tributaries was generally high using this method of comparison. Confidently estimating survival through the tributaries, is not likely using this method because the number of recoveries is so low.

CWT smolts released on the tributaries took between 7 to 22 days to arrive at Antioch and 8 and 16 days to arrive at Chipps Island. The groups released on the Stanislaus appeared to take the longest to arrive at Antioch and Chipps Island. Information on the transit time between release and recovery of the CWT groups released in the San Joaquin River mainstem and tributaries at both Antioch and Chipps Island is summarized in Appendix C-5. As observed for VAMP releases, recovery times were generally similar between Antioch and Chipps Island for the various groups released upstream in the mainstem San Joaquin and tributaries.

EVALUATION OF CHINOOK SALMON FRY SURVIVAL IN THE STANISLAUS RIVER: BIOLOGICAL RESPONSE TO SUPPLEMENTAL WINTER FLOW PULSE

contributed by Doug Demko, S.P. Cramer Consultant

Previous monitoring of juvenile salmon migration (1998–2002) from the Stanislaus River at Oakdale (RM 40.1) and Caswell (RM 8.6) indicates that survival of fall-run Chinook salmon fry (<45mm fork length) is greater under moderate winter flow conditions than under low winter flows. During intermediate to wet years (1998 through 2000), 75% or more of fry migrants passing Oakdale also passed Caswell during pulse flow events above 750 cfs. Flow pulses included natural freshets (i.e., short pulses in flow due to a rainfall event) and flood control releases. During dry years (i.e., 2001 and 2002), relatively small changes

TABLE 6-1

Survival indices and absolute survival estimates through the tributaries using recoveries at Antioch and Chipps Island for coded wire tagged smolts released as part of San Joaquin tributary studies in the spring of 2003.

Release Site	Date	Antioch Survival Indices	Antioch Absolute Survival	Chipps Survival Indices	Chipps Absolute Survival
Merced River Fish Facility (upper Merced)	4/13/03	0.012	0.38	0.016	0.26
Hatfield State Park (lower Merced)	4/16/03	0.032		0.060	
Merced River Fish Facility	4/25/03	0.00189	0.79	—	—
Hatfield State Park	4/29/03	0.00239		0.014	
Merced River Fish Facility	5/04/03	0.002	0.43	0.01977	0.96
Hatfield State Park	5/07/03	0.005		0.02064	
Knight's Ferry (upper Stanislaus)	4/25/03	0.005	0.34	0.006	—
Two Rivers (lower Stanislaus)	4/27–4/28/03	0.014		—	

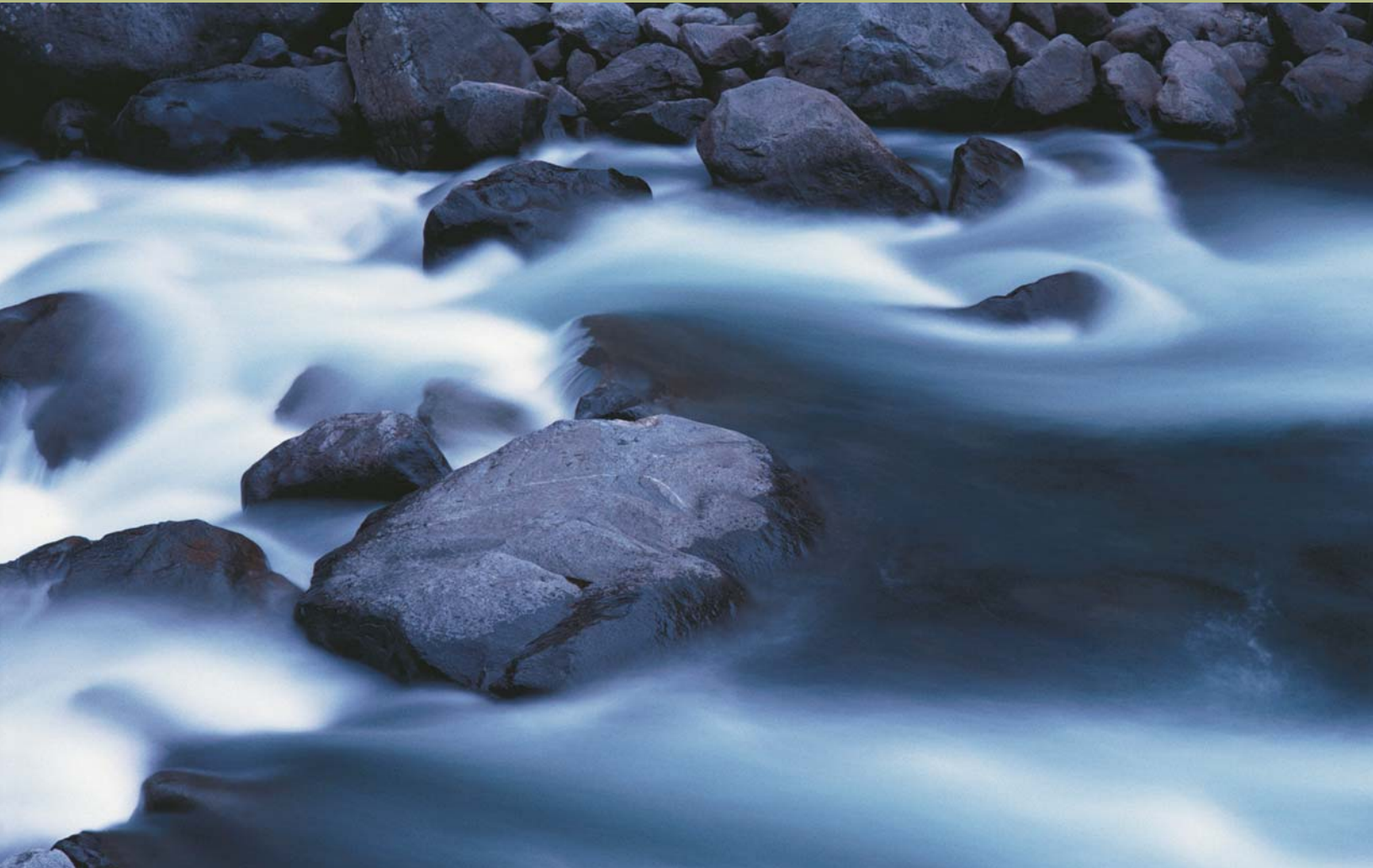



The objective of the flow experiment in the Stanislaus River during 2003 was to determine whether fry survival during dry or low flow years could be increased by managed flow pulses in winter.

in flow (e.g., 50 cfs) and turbidity had the ability to stimulate fish migration past Oakdale, however, less than 10% migrated as far downstream as Caswell. In years when low proportions of fry were observed passing between Oakdale and Caswell, there was no corresponding increase in the proportion of parr (45–70mm) and smolts (>70mm) passing between the two sites which indicates that fry did not rear in the river below Oakdale and subsequently migrate as older fish. Rather, in-river fry survival during these dry years was reduced. Although high winter flows during intermediate to wet years were found to increase fry migration and survival past Caswell, the subsequent fate of fry downstream in the San Joaquin River and Delta is unknown. In addition, it is uncertain whether high supplemental flows provided during dry years would result in increased in-river and/or downstream survival.

The objective of the flow experiment in the Stanislaus River during 2003 was to determine whether fry survival during dry, or low, (i.e., no natural freshets in excess of 1,000 cfs) flow years could be increased by managed flow pulses in winter. The purpose of the study was to evaluate whether a supplemental winter flow of approximately 1,000 cfs during a dry year could both stimulate and sustain fry migration out of the

Stanislaus River. The effectiveness of artificial freshets at increasing in-river fry survival was determined by estimating the proportion of fry that passed Caswell after passing Oakdale. Potential mortality through the San Joaquin River and Delta was assessed from fry salvage and loss rates at the CVP and SWP Delta export facilities during 1998–2003.

Studies of juvenile outmigration in 1998–2002 indicated that flow increases to less than 750 cfs for 1 to 2 days during January and February, stimulated fry passage at Oakdale, but few fish subsequently reached Caswell 31.5 miles downstream. In contrast, short duration flow increases above 750 cfs resulted in increased fry passage past both Oakdale and Caswell indicating that more than 750 cfs is needed to sustain fry migration from the upper river through the lower river and past Caswell (Table 6-2). In addition, fry migration past Caswell begins within 1 to 2 days of initial flow increases during a pulse event and peak passage typically occurs within 3 days.

In addition to flow fluctuations, turbidity was considered to be an important factor in stimulating migration and protecting outmigrants from predators (Gregory and Levings 1998, Ginetz and Larkin 1976). In dry years on the Stanislaus River, some turbidity is created by run-off, but is typically 25% or less of that created by run-off in wet years. Therefore, the 2003 flow experiment was intended to occur simultaneously with a rain event to take advantage of turbidity created by natural run-off.

During 2003, circumstances (i.e., hydropower facility maintenance) did not allow the experiment to coincide with a rain event as originally designed. Instead, the 2-day experiment began in late January when daily average flow, as measured at Goodwin Dam (RM 58.5), was increased from 280 cfs on the 26th to 1,003 cfs on the 28th and ramped down to 350 cfs by

TABLE 6–2
Observed Fry Response to Freshet Flows at Oakdale and Caswell during 1998 to 2002.

Daily Average Pulse Flow	Pulse Flow Duration	Fry Response
< 750	1 Day	Substantial passage at Oakdale No passage at Caswell
750	1 Day	Substantial pass at Oakdale Increased passage at Caswell
750 to 1,500	2 Days	Substantial passage at Oakdale Substantial passage at Caswell

FIGURE 6-1

2003 Supplemental pulse flow event of 1,000 cfs released from Goodwin Dam (RM58.4) including corresponding flows at Ripon (RM15.8) and fry passage at Caswell (RM8.6).

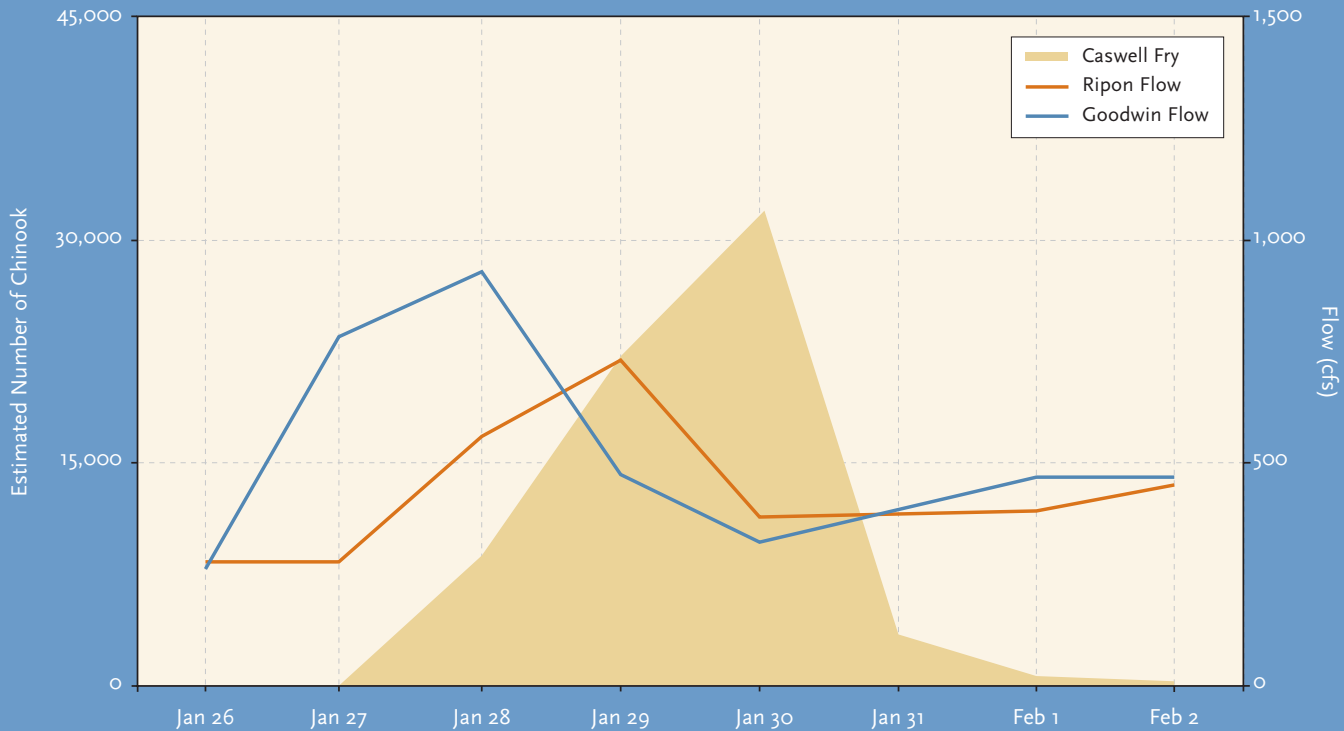

the 30th (Figure 6-1). Flow at Ripon followed a similar pattern, with a one day lag. Turbidity was measured at Ripon on the 29th and 30th and was 8.2 and 4.1 NTUs, respectively. Water temperature at Ripon decreased from 54.6°F on the 28th to 52.1°F on the 30th.

Throughout the 2003 supplemental flow period, rotary screw traps at Oakdale and Caswell were monitored frequently to ensure proper trap function and limit overcrowding of captured fish. Catch at Caswell increased within 1 day and peaked in 3 days of the beginning of the 2 day pulse event (Figure 6-1). When flows began to decrease, passage dropped sharply, but did not drop as low as levels observed in 2001 and 2002. During 2003, an estimated total of 79,137 fry moved past Caswell compared with fry passage in other low flow winters such as 6,376 in 2001 and 4,470 in 2002. However, in high flow winters, estimated totals of 809,614 fry and 1,018,946 fry moved past Caswell in 2000 and 1999, respectively. During January 2003, the artificial pulse flow and corresponding migratory response

were similar in magnitude and duration to a natural (i.e., freshet) pulse flow event that occurred during January 2000, which indicates that managed flow releases from reservoir storage can stimulate fry migration comparable to natural flows with similar characteristics.

Passage estimates for 2003 suggest that 5.1% of fry passing Oakdale also passed Caswell as fry. This represents approximately a five to 12-fold increase in the proportion of fry that reached Caswell during the same period in previous dry years including 2001 (0.9%) and 2002 (0.4%). Passage estimates indicate that providing supplemental winter flow releases of at least 750 cfs for 2 days stimulates and sustains migration of some fry past Caswell.

While the flow test indicates that additional fry can be moved out of the Stanislaus River, it still remains to be determined whether those fry survive to smolt through the Delta in a low flow year. Based on fish salvage and loss data at the CVP and SWP Delta export facilities from 1998–2002, large numbers of

FIGURE 6-2

Passage of fall-run Chinook salmon fry in 1998 at Caswell and salvage/loss at the CVP and SWP Delta facilities.

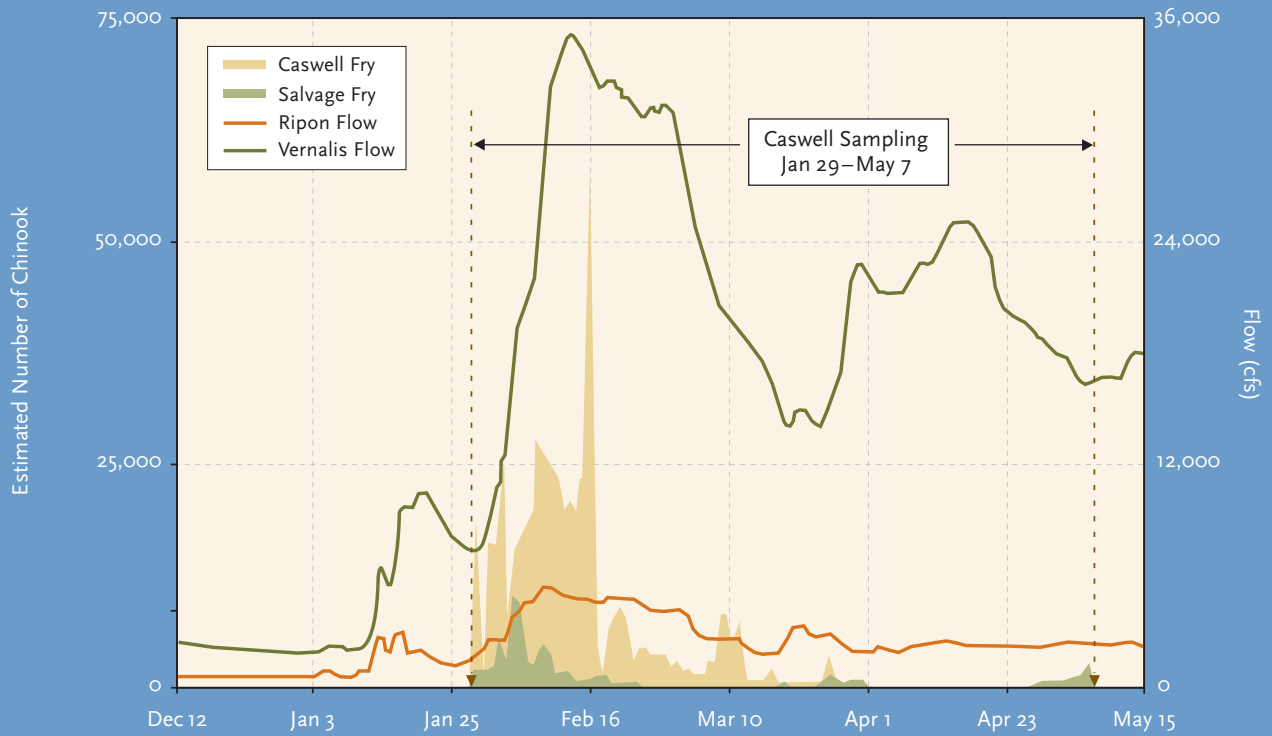
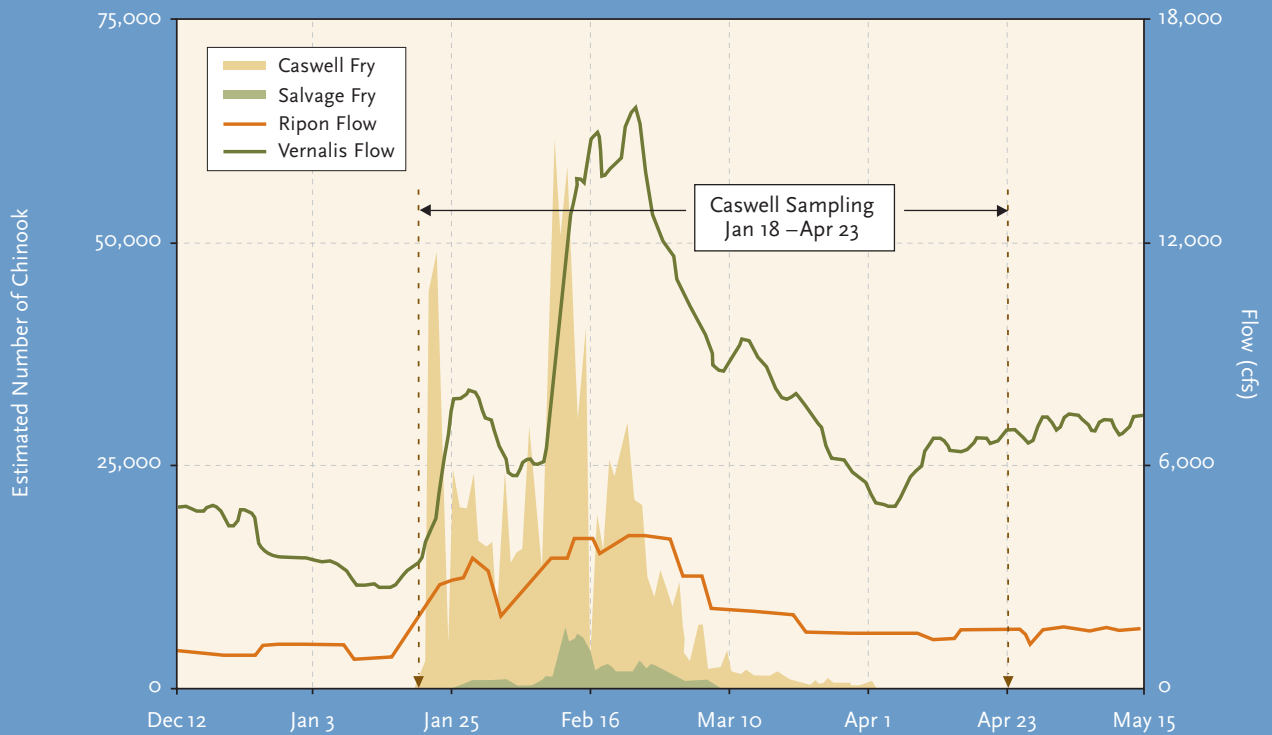

FIGURE 6-3

Passage of Fall-run Chinook salmon fry in 1999 at Caswell and salvage/loss at the CVP and SWP Delta facilities.



fry typically arrive at the facilities during intermediate and wet water years (i.e., 83,029 in 1998; 70,948 in 1999; and 82,299 in 2000) but not in dry years (i.e., 2,123 in 2001; 718 in 2002; and 2,604 in 2003). Although the origin of fry arriving at the Delta facilities can not be confirmed, the observed peaks in fry salvage and loss in intermediate/wet years typically occur within 6 to 14 days after initial flow increases in the Stanislaus River during pulse flow events, and within 2 to 8 days of associated Caswell outmigration peaks (Figures 6-2 thru 6-7).

In 2003, the total fry salvage and loss at the Delta CVP and SWP facilities was 2,604 which is similar to other dry years. However, a majority (i.e., 2,130) were observed between 5 to 10 days following the initial Stanislaus River pulse flow, with the peak (i.e., 1,202) occurring within 7 days of the pulse. This correspondence in timing of fry passage indicates that fry observed at the Delta facilities from February 1 to 6 can be attributed to the Stanislaus River. Further, the data indicate fry were able to successfully migrate from the Stanislaus River, through the lower San Joaquin River, and into the Delta. However, the large numbers of fry observed at the Delta facilities still leave open the possibility that fry during these low flow conditions may not survive in the Delta until they reach the smolt stage.

Since fry were not tagged for this experiment, it is impossible to estimate fry survival through the Delta at this time. Although this evaluation determined that fry can be stimulated to migrate out of the Stanislaus River in dry years with artificial flow releases around 1,000 cfs, additional supplemental winter pulse flow experiments are recommended with the development and implementation of a coordinated fry coded-wire tagging program. Such a program is suggested in order to estimate survival of fry through the Delta and ocean stage of the salmon lifecycle. The long-term survival and relative contribution of fry to the population can only be ascertained through a permanent tagging and recovery program.

RADIO TAGGING STUDIES IN THE LOWER SAN JOAQUIN RIVER

contributed by David Vogel, Natural Resources Scientists, Inc.

During April and May 2003, Natural Resource Scientists, Inc. released and monitored radio-tagged juvenile Chinook salmon in the lower San Joaquin River. Field data collection for this project was designed to acquire information on specific behavior (movements) as juvenile Chinook salmon migrated through delta channels just prior to and during VAMP implementation. The 2003 study expanded upon the techniques NRS developed in prior studies on juvenile salmon using radio telemetry, including recent studies at the Delta Cross Channel and the north, south and central Delta regions.

Juvenile Chinook salmon with surgically-implanted miniature (1 gram) radio transmitters were released in the San Joaquin River near Fourteen-Mile Slough (downstream of Stockton). Twelve to 13 radio-tagged salmon were released on each of the following dates: April 8 (pre-VAMP), April 15, April 22, and April 29 (during VAMP). The radio-tagged fish were tracked for 4 days after release using mobile receivers on two inboard jet boats. Individual fish movements, migration rates, and behavior in response to tidal cycles and flow splits in Delta channels were important parameters assessed from field observations. In particular, the project was intended to evaluate what occurs during the telemetered salmon migration past the flow splits at Turner Cut, Columbia Cut, and lower Middle and Old rivers. Each time a radio-tagged fish was located, the exact position (via GPS), time, and any relevant biological and behavioral observations were recorded. Figures 6-8 through 6-11, and show preliminary data on locations of radio-tagged juvenile Chinook salmon released and tracked in the Delta during the four weeks of experiments.

A report on this project will be completed after receipt of DWR tidal flow data measured in the San Joaquin River near Rough and Ready Island.

FIGURE 6-4

Passage of Fall-run Chinook salmon fry in 1999 at Caswell and salvage/loss at the CVP and SWP Delta facilities.

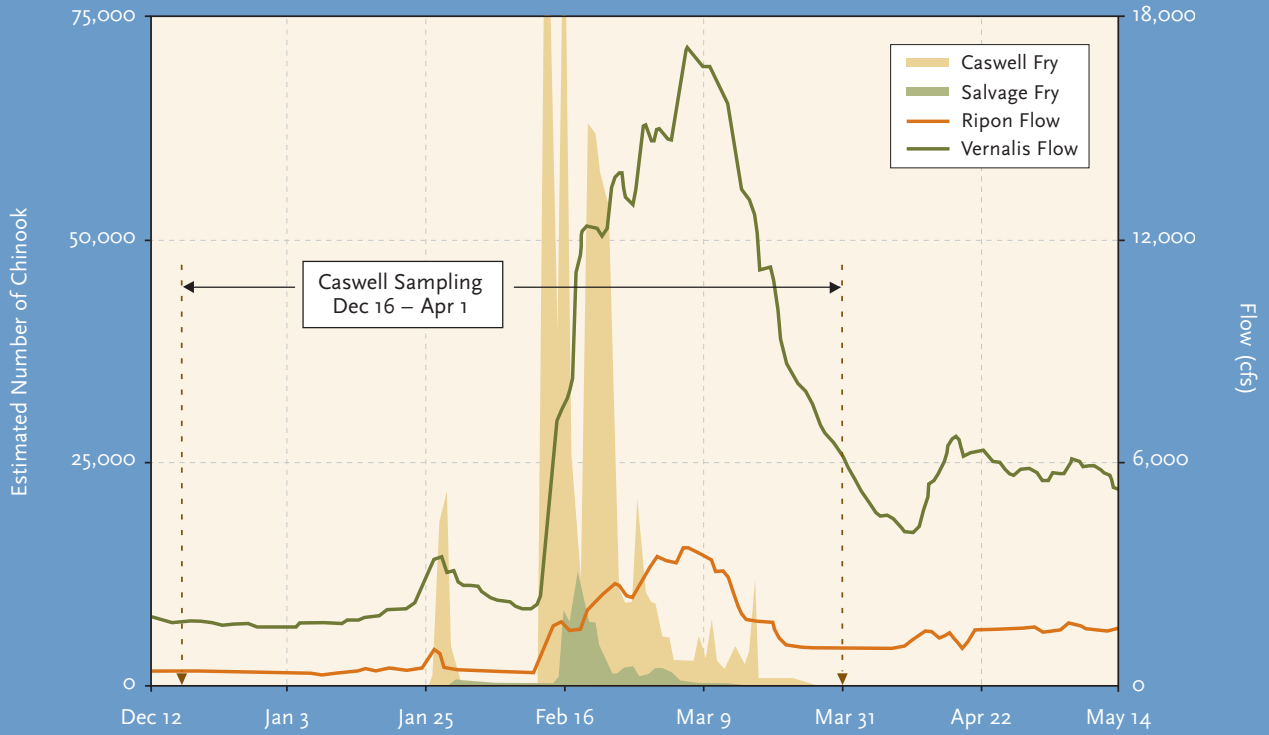

FIGURE 6-5

Passage of fall-run Chinook salmon fry in 2001 at Caswell and salvage/loss at the CVP and SWP Delta facilities

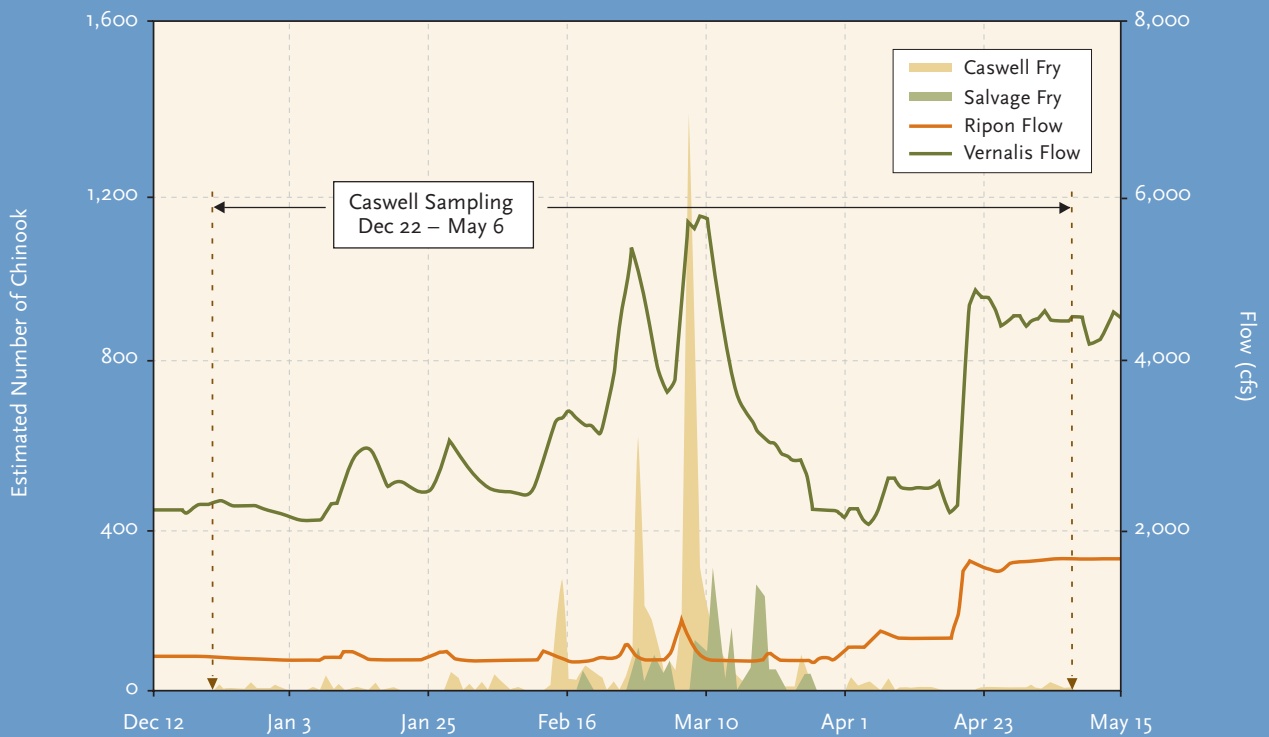

FIGURE 6-6

Passage of fall-run Chinook salmon fry in 2001 at Caswell and salvage/loss at the CVP and SWP Delta facilities

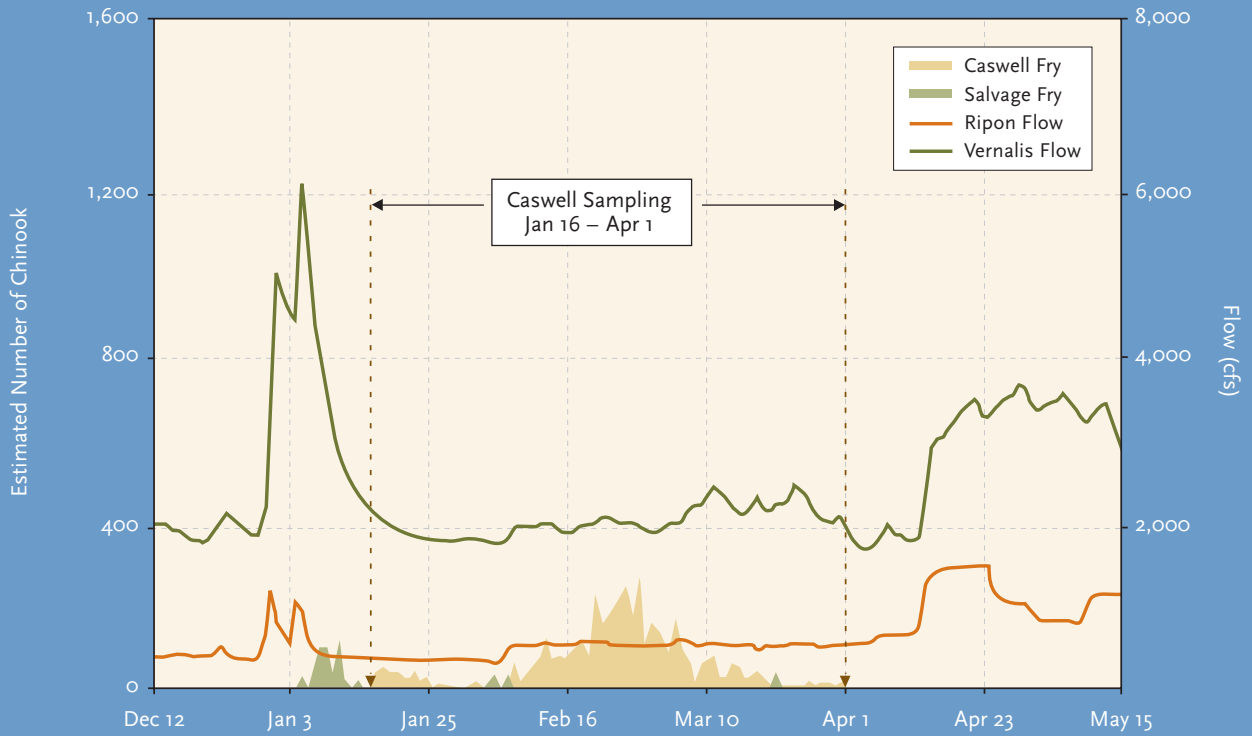

FIGURE 6-7

Passage of fall-run Chinook salmon fry in 2003 at Caswell and salvage/loss at the CVP and SWP Delta facilities.
Fry passage at Caswell on Feb 14 was 145,565 and 94,358 on Feb 16.

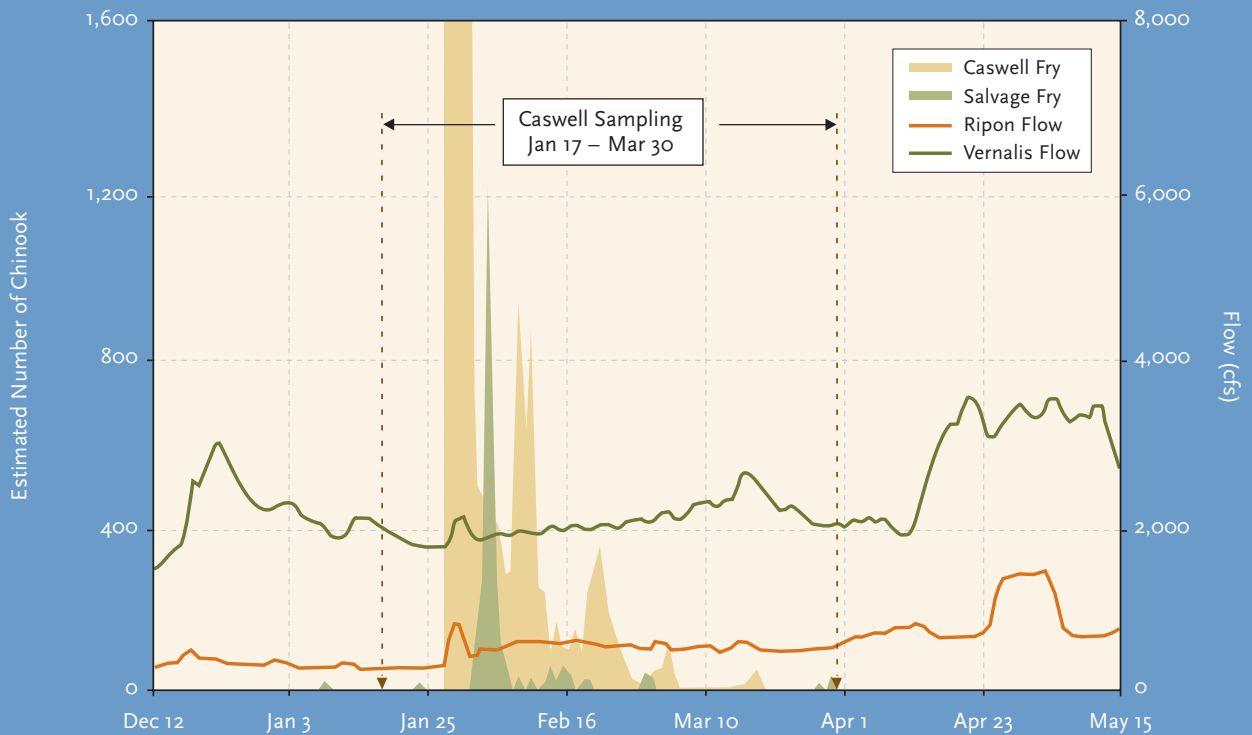

FIGURE 6-8

Locations of Radio-Tagged Juvenile Salmon, Release #1 on April 8, 2003.

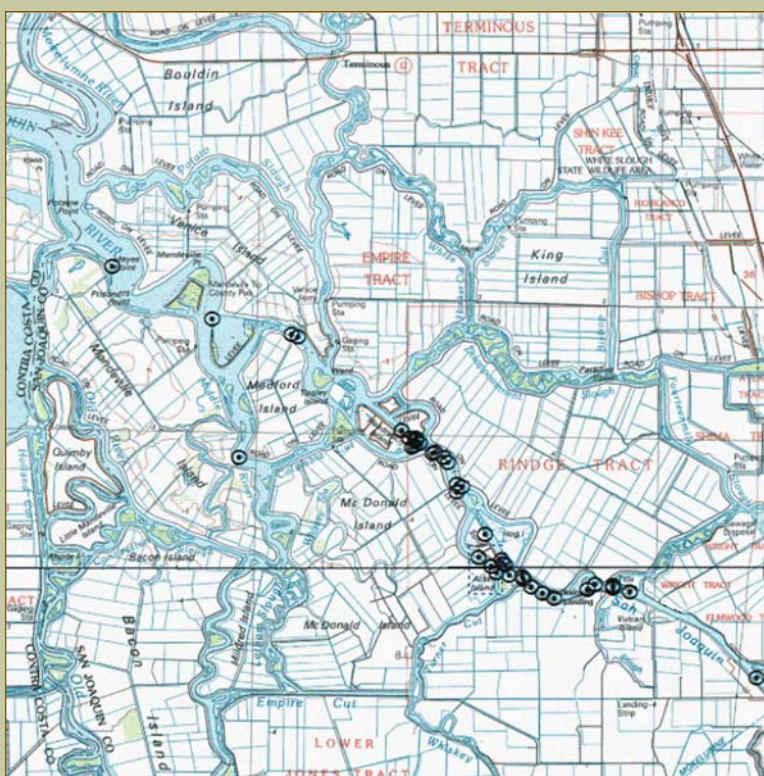

FIGURE 6-9

Locations of Radio-Tagged Juvenile Salmon, Release #2 on April 15, 2003.

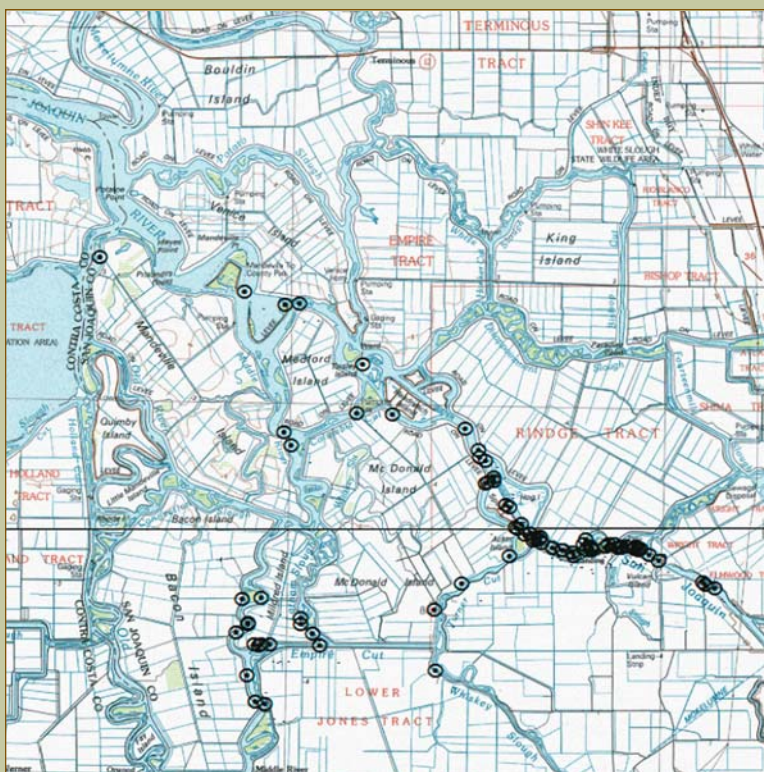

FIGURE 6-10

Locations of Radio-Tagged Juvenile Salmon, Release #3 on April 22, 2003.

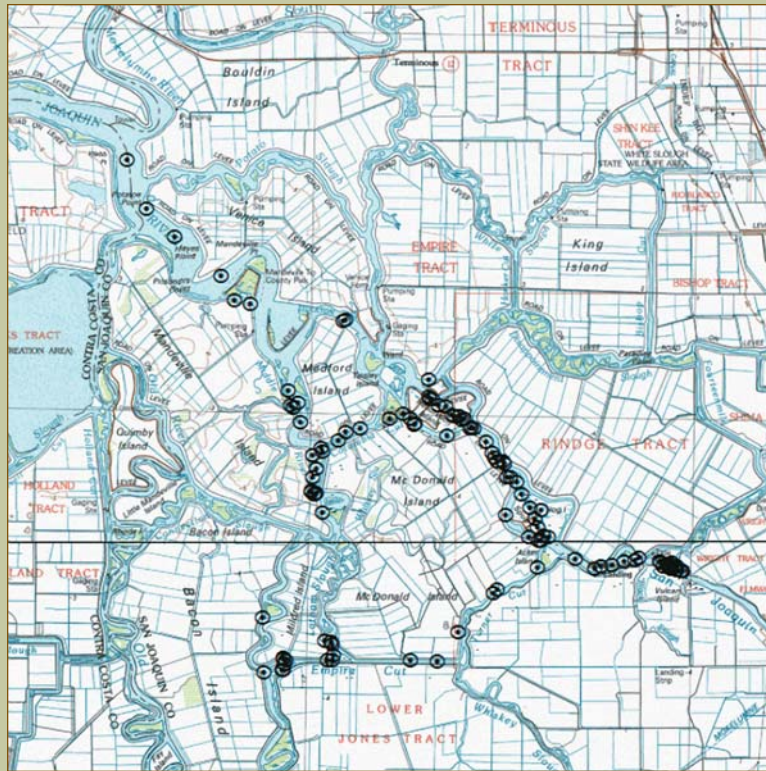
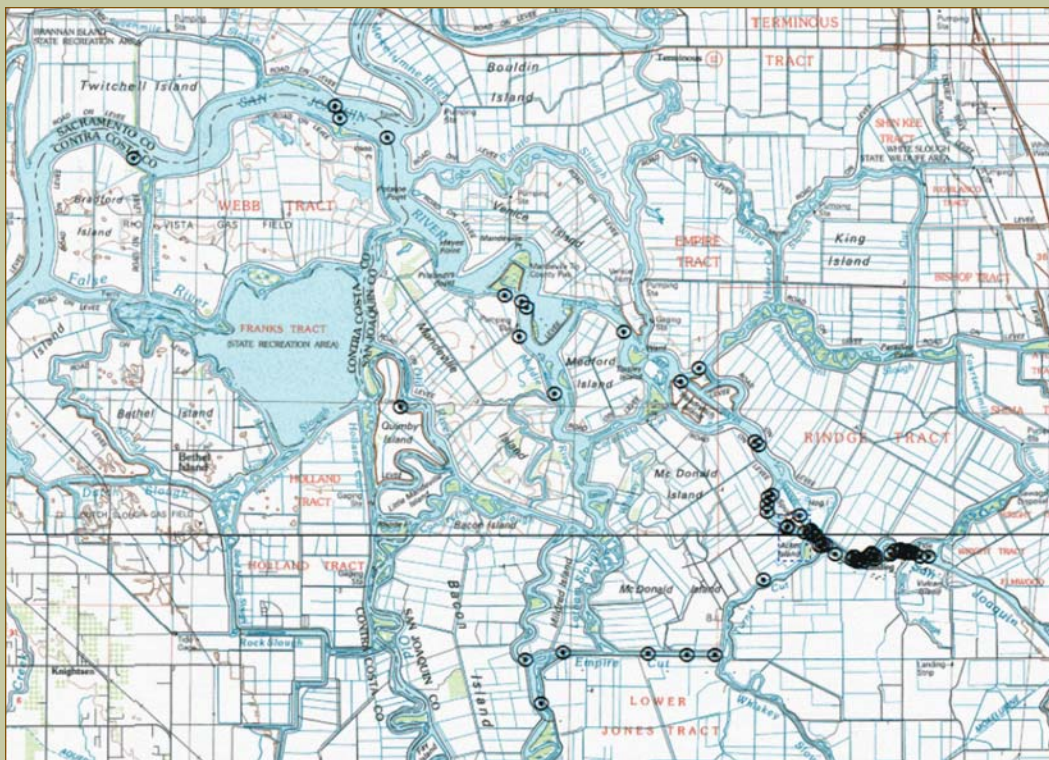

FIGURE 6-11

Locations of Radio-Tagged Juvenile Salmon, Release #4 on April 29, 2003.



CHAPTER 7

Conclusions & Recommendations

The VAMP experimental investigation of juvenile Chinook salmon survival was implemented during spring 2003. The Vernalis target flow was 3200 cfs, with a combined SWP and CVP export rate of 1500 cfs. The HORB was successfully installed and maintained throughout the VAMP test period. Estimates of juvenile Chinook salmon smolt survival were calculated based upon recoveries of CWT juvenile salmon produced in the Merced River Fish Facility and released at Durham Ferry, Mossdale, and Jersey Point. Marked salmon were subsequently recaptured in sampling at the HORB, SWP and CVP export facility salvage, and through intensive fisheries sampling at Antioch and Chipps Island. Based upon the data and experience gained during the VAMP 2003 investigations, conclusions and recommendations have been developed, as summarized in

Table 7-1. The conclusions and recommendations include both technical and policy/management issues that will affect the design and implementation of VAMP 2004 operations and investigations.

Based on testing the relationship of salmon survival rates against flow and export conditions in 2000, 2001, 2002, and 2003 it has been shown that survival generally improves as flows increase and flows relative to exports increase. With the addition of the 2003 data, the relationships between salmon survival rates and Vernalis flows to SWP/CVP export ratios are no longer statistically significant. Survival tests at extreme target levels are important to obtain. The VAMP program provides improved protection for juvenile salmon when compared to “pre-VAMP” conditions.

TABLE 7-1
Summary of VAMP 2003 conclusions and recommendations

Conclusions	Recommendations
Hydrologic measurements at Vernalis were improved by weekly verification of rating curves.	Continue weekly flow measurements. Investigate alternative flow measurement methods and/or locations. Obtain additional funding for USGS weekly Vernalis gage verification.
Estimation of ungaged flows (accretions, depletions) at Vernalis was improved.	Continue hydrology investigation to improve predictions of ungaged flows.
Flow in the lower San Joaquin River downstream of Old River is important to evaluating salmon survival.	Calibrate the stage and flow monitoring system prior to the 2004 VAMP test period.
Confusion over forecasting New Melones releases impacted planning for tributary flows and related operations.	Management committee should resolve forecasting issues prior to 2004 VAMP and a set of written procedures for operational planning within each tributary should be established.
Coordination with upstream tributary operations was successful.	Continue coordination among tributary operators.
First release of CWT test fish was delayed five days to allow for completion of construction, clean-up, and flushing of debris from culverts.	Continue to work with DWR and resource agencies on scheduling construction of HORB to facilitate VAMP releases as quickly after barrier closure as possible.

Conclusions Continued	Recommendations Continued
<p>Operation of the HORB was successful in maintaining south delta water levels.</p>	<p>Continue to refine operational criteria for culverts, water level modeling, and groundwater level monitoring.</p>
<p>Closure of HORB is dependent on completion of other barriers. Construction of multiple barriers in south delta channels may delay HORB closure.</p>	<p>Continue to work with DWR and resource agencies on scheduling construction of south Delta barriers to facilitate VAMP releases as quickly after barrier closure as possible.</p>
<p>An estimate of the flow through the culverts was obtained through use of measuring device in culvert #4.</p>	<p>Take flow measurements within each culvert during the 2004 VAMP.</p>
<p>The use of fyke nets was successful in collecting entrained fish at the culverts.</p>	<p>Continue monitoring culverts using fyke nets to document fish entrainment.</p>
<p>The index of salmon entrainment at HORB was substantially higher in 2003 (3.4 salmon per hour) with three culvert operated compared to 2002 (2.5 salmon per hour and 2001 (1.4 salmon per hour) when all six culverts were operated.</p> <p>Most salmon were entrained at night in 2003, similar to prior years. The relationship between tidal condition and salmon entrainment at HORB was variable.</p>	<p>Continue barrier monitoring and analysis of factors affecting entrainment.</p> <p>The split releases at Mossdale should be continued to evaluate tidal-diel interactions affecting salmon entrainment.</p>
<p>2003 studies were successful in determining salmon entrainment at HORB culverts, but did not estimate mortality associated with HORB.</p>	<p>Evaluate methods to estimate mortality associated with HORB.</p>
<p>The release at Durham Ferry was improved by having the diversion pump at the site curtail operation.</p> <p>Water temperatures were suitable during both sets of releases.</p>	<p>Continue to curtail diversion pump operations during releases—coordinate release schedule with landowner.</p> <p>Avoid seasonal delays in barrier installation and survival testing to allow releases when most suitable water temperatures.</p>
<p>Results of net pen studies showed a 1/2 percent mortality rate in 2003 compared to no mortality in 2002.</p>	<p>Continue net pen studies and fish health inspections.</p>
<p>Physiological studies provided useful information on fish health and condition and indicated PKD may have been a factor in survival particularly for the second set of releases.</p> <p>There were few consistent patterns in blood chemistry values among releases groups. Comparisons were complicated by differences in transport time and handling.</p>	<p>Recommend continued health monitoring to compare within and between year trends of health and condition.</p> <p>Baseline data for blood chemistry analyses should be taken from unstressed fish (not subjected to stress for 24 or more hours).</p>
<p>2003 survival rates were the lowest since the initiation of the VAMP and were significantly lower than those in 2002 under similar flow and export conditions.</p>	<p>Continue to evaluate differences in survival rates between release locations, flows, and export conditions.</p>
<p>Survival from Durham Ferry and Mossdale in 2003 was significantly less than prior years. Further evaluation of survival rate versus flow and export rate is needed to detect differences in survival.</p>	<p>Repeat the 2003 target flow and export condition in the future when conditions allow. Testing 7000 cfs flow and 1500 cfs export rate is recommended to determine survival under higher flow/export ratio. Continue VAMP test program.</p>
<p>Complimentary studies to evaluate mechanisms affecting survival of fish from tributaries and through the Delta were conducted.</p> <p>Relatively few CWT salmon from VAMP releases were recovered at the SWP and CVP salvage facilities.</p>	<p>Encourage an expansion of complementary studies to provide additional information on factors and mechanisms affecting salmon survival.</p> <p>Continue salvage monitoring to document direct losses at SWP/CVP export facilities.</p>

REFERENCES CITED

Brandes P.L., McLain J.S. 2001. Juvenile Chinook Salmon Abundance, Distribution, and Survival in the Sacramento–San Joaquin Estuary. In: Brown RL, editor. Contributions to the Biology of Central Valley Salmonods. Fish Bulletin 179. Volume 2. Sacramento (CA): California Department of Fish and Game. p 39–136. On website: http://www.delta.dfg.ca.gov/usfws/Reports/SSJEFRO_Reports.html

Department of Water Resources, 2001. South Delta Temporary Barriers Project: 1999 Fishery, Water Quality, and Vegetation Monitoring Report. September 2001.

Department of Water Resources, 1998. Temporary Barrier Project: Fishery, Water Quality, and Vegetation Monitoring 1997. Environmental Services Office. June 1998.

Ginetz, R.M. and P.A. Larkin. 1976. Factors affecting rainbow trout (*Salmo gairdneri*) predation on migrant fry of sockeye salmon (*Oncorhynchus nerka*). Journal of Fisheries Reserve Board Canada 33:19–24.

Gregory, R.S. and C.D. Levings. 1998. Turbidity reduces predation on migrating juvenile Pacific salmon. Transactions of the American Fisheries Society 127:275–285.

Hedrick, R.P. and D. Aronstien. 1987. Effects of saltwater on the progress of proliferative kidney disease (PKD) in Chinook salmon (*Oncorhynchus tshawytscha*). Bulletin of the European Association of Fish Pathologists 7:93–96.

San Joaquin River Group Authority, 2002. 2001 Annual Technical Report on the Implementation and Monitoring of the San Joaquin River Agreement and the Vernalis Adaptive Management Plan. January 2002. 125 pgs.

San Joaquin Rver Group Authority, 2003. 2002 Annual Technical Report on the Implementation and Monitoring of the San Joaquin River Agreement and the Vernalis Adaptive Management Plan. January 2003. 119 pgs.

Newman, Ken, personal communication. Professor of Statistics at University of St. Andrews, Scotland.

Nichols and Foott, 2003. FY 2003 Investigational Report: Health and Physiological Assessment of VAMP Release Groups—2003. US Fish and Wildlife Service, California—Nevada Fish Health Center, Anderson, CA. August 2003. 6 pgs.

Nichols, K. USFWS. Personal communication. US Government Memorandum dated 12/06/02. Subject: Merced River PKD Survey—Spring 2002.

Kwan, Simon, DWR. Personal communication. California Department of Water Resources, Sacramento, CA.

CONTRIBUTING AUTHORS

Michael Archer

MBK Engineers, *Sacramento*

Patricia Brandes

U.S. Fish and Wildlife Service, *Stockton*

Mike Marshall

U.S. Fish and Wildlife Service, *Stockton*

Lia McLaughlin

U.S. Fish and Wildlife Service, *Stockton*

Andy Rockriver

California Department of Fish and Game, *Stockton*

Tim Ford

Modesto and Turlock Irrigation Districts, *Modesto, Turlock*

Charles Hanson

Hanson Environmental, Inc., *Walnut Creek*

Mark Holderman

California Department of Water Resources, *Sacramento*

Simon Kwan

California Department of Water Resources, *Sacramento*

Mike Abioui

California Department of Water Resources, *Sacramento*

Lowell Ploss

San Joaquin River Group Authority, *Modesto*

SIGNATORIES TO THE SAN JOAQUIN RIVER AGREEMENT

U.S. Bureau of Reclamation

U.S. Fish and Wildlife Service

California Department of Water Resources

California Department of Fish and Game

Oakdale Irrigation District*

South San Joaquin Irrigation District*

Modesto Irrigation District*

Turlock Irrigation District*

Merced Irrigation District*

San Joaquin River Exchange Contractors
Water Authority*

Central California Irrigation District

Firebaugh Canal Water District

Columbia Canal Company

Sal Luis Canal Company

Friant Water Users Authority*

Public Utilities Commission of the City
and County of San Francisco*

Natural Heritage Institute

Metropolitan Water District of Southern California

San Luis and Delta–Mendota Canal Water Authority

San Joaquin River Group Authority

** San Joaquin River Group Authority Members*

USEFUL WEB PAGES



PAGE 3

San Joaquin River Agreement

www.sjrg.org/agreement.htm

PAGE 3

SWRCB Decision 1641

www.waterrights.ca.gov/hearings/Decisions.htm

PAGE 4

VAMP 2002 Annual Technical Report

www.sjrg.org/technicalreport/2002_tech_report.htm

PAGE 9

VAMP Experimental Design

www.sjrg.org/agreement.htm

PAGE 12

Operation Monitoring, CDEC Hourly

cdec.water.ca.gov/cgi-progs/queryGroup?s=fw1

Operation Monitoring, CDEC Daily

cdec.water.ca.gov/cgi-progs/queryDgroups?s=fw2

Vernalis USGS Real-Time

waterdata.usgs.gov/nwis/uv?format=pre&period=1&site_no=11303500

Vernalis, USGS Daily

waterdata.usgs.gov/ca/nwis/dv?format=pre&period=31&site_no=11303500

Newman, USGS Daily

waterdata.usgs.gov/ca/nwis/dv?format=pre&period=31&site_no=11274000

Cressey, CDEC Daily

cdec.water.ca.gov/cgi-progs/queryF?s=crs

Stevinson, CDEC Daily

cdec.water.ca.gov/cgi-progs/queryF?s=mst

LaGrange, USGS Daily

waterdata.usgs.gov/ca/nwis/dv?format=pre&period=31&site_no=11289650

Goodwin, USBR Daily

www.usbr.gov/mp/cvo/vungvari/gdwdop.pdf

PAGE 22

Temporary Barrier Program

sdelta.water.ca.gov

PAGE 27

Reclamation District 544 Seepage Monitoring Study

sdelta.water.ca.gov

PAGE 35

HORB on Old River Tidal Stage

cdec.water.ca.gov

PAGE 65

CVP and SWP Salvage Data

www.iep.ca.gov/dfishfa/fmt.html

USFWS Stockton

www.delta.dfg.ca.gov/usfws/monitoring_main/monitoring_main.html

Pacifica States Marine Fisheries Commission

Regional Mark Information System

www.rmis.org

HORB on Old River Tidal Stage

cdec.water.ca.gov

COMMON ACRONYMS & ABBREVIATIONS

ACDP	Acoustic Doppler Current Profiler	NOAA	National Marine Fisheries Service
Bay-Delta	Sacramento and San Joaquin Rivers San Francisco Bay Delta	OID	Oakdale Irrigation District
CDEC	California Data Exchange Center	ORT	Old River at Tracy
CDRR	Combined Differential Recovery Rate	PKD	Proliferative Kidney Disease
CFS	Cubic Feet Per Second	SDWA	South Delta Water Agency
CPUE	Catch Per Unit Effort	SJRA	San Joaquin River Agreement
CRR	Combined Recovery Rate	SJREC	San Joaquin River Exchange Contractors Water Authority
CVP	Central Valley Project	SJRGA	San Joaquin River Group Authority
CWT	Code Wire Tagged	SJRTC	San Joaquin River Technical Committee
D-1641	Water Rights Decision 1641 of the SWRCB	SSJID	South San Joaquin Irrigation District
DFG	California Department of Fish and Game	SWP	State Water Project
DWR	California Department of Water Resources	SWRCB	California State Water Resources Control Board
GLC	Grant Line Canal	TBP	Temporary Barriers Project
HOR	Head of Old River	TID	Turlock Irrigation District
HORB	Head of Old River Barrier	USBR	United States Bureau of Reclamation
Merced	Merced Irrigation District	USFWS	United States Fish and Wildlife Service
MID	Modesto Irrigation District	USGS	United States Geologic Survey
MR	Middle River	VAMP	Vernalis Adaptive Management Plan
MSL	Mean Sea Level	WQCP	Water Quality Control Plan for the Bay-Delta Estuary

APPENDIX TABLE OF CONTENTS

APPENDIX A:

Hydrology & Operation Plans	90
A-1 VAMP Daily Operation Plan, Tables 1–8	91
A-2 Final Accounting of Supplemental Water Contributions, Table 1	99
A-3 Comparison of “Real-time” and Provisional Flows, Figures 1–7	100
A-4 Daily Measured Flow in Old River	103

APPENDIX B:

Fall Water Transfer and Delivery Information	104
B-1 Merced I.D. 2003 Fall SJRA Water Transfer Daily Summary	105
B-2 Merced I.D. 2002 Fall Water Transfer Daily Summary, FINAL	106

APPENDIX C:

Chinook Salmon Survival Investigations	107
C-1 Water Temperature Location Map	108
C-1 Water Temperature Monitoring Locations	109
C-2 Water Temperature Monitoring Data, Plots 1–11	110
C-3 Net Pen Sampling Results, Tables C-3a, C-3b	114
C-4 Coded Wire Tag Recovery Data — Antioch	116
C-4 Coded Wire Tag Recovery Data — Chipps Island	119
C-5 Coded Wire Tag Recovery Information, Table C-5	122

APPENDIX D:

Errata	123
Errata for the 2002 Annual Technical Report	123



APPENDIX A

Hydrology & Operation Plans

Appendix A–1, Table 1
VAMP DAILY OPERATION PLAN, MARCH 12, 2003 (A) • LOW

Target Flow Period: April 15 – May 15 • Flow Target: 3,200 cfs

	San Joaquin River near Vernalis					Merced River at Cressey					Tuolumne River at LaGrange				Stanislaus River below Goodwin				Maintain Priority Flow Level M=Merced T=Tuol. S=Stan.	
	Existing Flow	VAMP Suppl. Flow	Other Suppl. Flow	Cum. VAMP Suppl. Flow	VAMP Flow	SJR above Merced R. (2-day lag)	Ungaged Flow above Vernalis	Existing Flow	MeID VAMP Suppl. Flow	Exch Contr VAMP Suppl. Flow	VAMP Flow (3-day lag)	Desired FERC Pulse	Existing Flow – Adjusted FERC Pulse	VAMP Suppl. Flow	VAMP Flow (2-day lag)	Existing Flow	VAMP Suppl. Flow	Other Suppl. Flow		VAMP Flow (2-day lag)
	(cfs)	(cfs)	(cfs)	(TAF)	(cfs)	(cfs)	(cfs)	(cfs)	(cfs)	(cfs)	(cfs)	(cfs)	(cfs)	(cfs)	(cfs)	(cfs)	(cfs)	(cfs)		(cfs)
Apr 01						400	300	250			250	150	150		150	763			763	
Apr 02						397	300	250			250	150	150		150	763			763	
Apr 03						393	300	250			250	150	150		150	763			763	
Apr 04	1,860			1,860		390	300	250			250	150	150		150	763			763	
Apr 05	1,856			1,856		386	300	250			250	150	150		150	763			763	
Apr 06	1,853			1,853		383	300	250			250	150	150		150	763			763	
Apr 07	1,849			1,849		379	300	250			250	150	150		150	763			763	
Apr 08	1,846			1,846		376	300	250			250	150	150		150	763			763	
Apr 09	1,842			1,842		372	300	250			250	150	150		150	763			763	
Apr 10	1,839			1,839		369	300	250			250	150	150		150	763			763	
Apr 11	1,835			1,835		365	300	250	250		500	150	150		150	763			763	
Apr 12	1,832			1,832		362	300	250	501	119	870	275	275		275	763			763	
Apr 13	1,828	0		1,828		360	300	250	571	119	940	400	400	150	550	763	300	0	1,063	
Apr 14	1,950	250		2,200		356	300	250	581	119	950	400	400	150	550	763	300	0	1,063	
Apr 15	2,073	1,070	0	2.12	3,143	352	300	250	531	119	900	386	386	150	536	763	300	0	1,063	
Apr 16	2,069	1,140	0	4.38	3,209	349	300	250	531	119	900	441	441	150	591	763	300	0	1,063	
Apr 17	2,051	1,150	0	6.66	3,201	345	300	250	541	119	910	441	441	150	591	763	300	0	1,063	
Apr 18	2,103	1,100	0	8.85	3,203	341	300	250	541	119	910	441	441	150	591	763	300	0	1,063	
Apr 19	2,099	1,100	0	11.03	3,199	337	300	250	551	119	920	441	441	150	591	763	300	0	1,063	
Apr 20	2,095	1,110	0	13.23	3,205	334	300	250	551	119	920	441	441	150	591	763	300	0	1,063	
Apr 21	2,092	1,110	0	15.43	3,202	330	300	250	551	119	920	441	441	150	591	763	300	0	1,063	
Apr 22	2,088	1,120	0	17.65	3,208	326	300	250	551	119	920	441	441	150	591	763	300	0	1,063	
Apr 23	2,084	1,120	0	19.87	3,204	322	300	250	451	119	820	441	441	150	591	763	300	0	1,063	
Apr 24	2,080	1,120	0	22.10	3,200	319	300	250	451	119	820	718	718	300	1,018	763	0	0	763	
Apr 25	2,077	1,120	0	24.32	3,197	315	300	250	451	119	820	718	718	300	1,018	763	0	0	763	
Apr 26	2,349	870	0	26.04	3,219	311	300	250	451	119	820	718	718	300	1,018	763	0	0	763	
Apr 27	2,346	870	0	27.77	3,216	307	300	250	451	119	820	718	718	300	1,018	763	0	0	763	
Apr 28	2,342	870	0	29.49	3,212	304	300	250	451	119	820	718	718	300	1,018	763	0	0	763	
Apr 29	2,338	870	0	31.22	3,208	300	300	250	451	119	820	718	718	300	1,018	763	0	0	763	
Apr 30	2,334	870	0	32.95	3,204	296	300	250	451	119	820	718	718	300	1,018	763	0	0	763	
May 01	2,330	870	0	34.67	3,200	292	300	250	451	119	820	718	718	300	1,018	733	0	0	733	
May 02	2,327	870	0	36.40	3,197	288	300	250	641	119	1,010	494	494	300	794	733	340	0	1,073	
May 03	2,293	870	0	38.12	3,163	285	300	250	771	119	1,140	331	331	200	531	733	340	0	1,073	
May 04	2,065	1,210	0	40.52	3,275	281	300	250	771	119	1,140	331	331	100	431	733	340	0	1,073	
May 05	1,898	1,300	0	43.10	3,198	277	300	250	771	119	1,140	331	331	100	431	733	340	0	1,073	
May 06	1,895	1,330	0	45.74	3,225	273	300	250	771	119	1,140	331	331	100	431	733	340	0	1,073	
May 07	1,891	1,330	0	48.38	3,221	270	300	250	771	119	1,140	331	331	100	431	733	340	0	1,073	
May 08	1,887	1,330	0	51.01	3,217	266	300	250	771	119	1,140	331	331	100	431	733	340	0	1,073	
May 09	1,883	1,330	0	53.65	3,213	262	300	250	771	119	1,140	317	317	100	417	733	340	0	1,073	
May 10	1,897	1,330	0	56.29	3,209	258	300	250	771	119	1,140	317	317	100	417	733	340	0	1,073	
May 11	1,862	1,330	0	58.93	3,192	255	300	250	771	119	1,140	303	303	100	403	733	340	0	1,073	
May 12	1,858	1,330	0	61.57	3,188	251	300	250	771	119	1,140	303	303	100	403	733	340	0	1,073	
May 13	1,840	1,330	0	64.20	3,170	247	300	250	771		600	303	303	100	403	733	340	0	1,073	
May 14	1,837	1,330	0	66.84	3,167	243	300	250	50		300	225	225		225	733			733	
May 15	1,833	1,330	0	69.48	3,163	240	300	250			250	150	150		150	733			733	
May 16	1,751	350			2,101	236	300	250			250	150	150		150	733			733	
May 17	1,673	50			1,723	232	300	250			250	150	150		150	733			733	
May 18	1,669	0			1,669	229	300	250			250	150	150		150	733			733	
May 19	1,665	0			1,665	225	300	250			250	150	150		150	733			733	
May 20	1,662	0			1,662	221	300	250			250	150	150		150	733			733	
May 21	1,658	0			1,658	217	300	250			250	150	150		150	733			733	
May 22	1,654	0			1,654	214	300	250			250	150	150		150	733			733	
May 23	1,650	0			1,650	210	300	250			250	150	150		150	733			733	
May 24	1,647	0			1,647	206	300	250			250	150	150		150	733			733	
May 25	1,643	0			1,643	203	300	250			250	150	150		150	733			733	
May 26	1,639	0			1,639	199	300	250			250	150	150		150	733			733	
May 27	1,636	0			1,636	195	300	250			250	150	150		150	733			733	
May 28	1,632	0			1,632	192	300	250			250	150	150		150	733			733	
May 29	1,628	0			1,628	188	300	250			250	150	150		150	733			733	
May 30	1,625	0			1,625	184	300	250			250	150	150		150	733			733	
May 31	1,621	0			1,621	180	300	250			250	150	150		150	733			733	
VAMP period																				
Avg. (cfs):	2,071	1,130			3,201	304	300	250	594	119	963	467	467	179	646	750	238	0	988	
Suppl. Water (TAF)		69.48							36.52	7.32				11.01			14.64			

Target flow period
 Period of desired flow stability

Appendix A-1, Table 2
VAMP DAILY OPERATION PLAN, MARCH 12, 2003 (B) • HIGH

Target Flow Period: April 15–May 15 • Flow Target: 3,200 cfs

San Joaquin River near Vernalis					Merced River at Cressey					Tuolumne River at LaGrange				Stanislaus River below Goodwin				Maintain Priority Flow Level M=Merced T=Tuolumne	
Existing Flow	VAMP Suppl. Flow	Other Suppl. Flow	Cum. VAMP Suppl. Flow	VAMP Flow	SJR above Merced R. (2-day lag)	Ungaged Flow above Vernalis	Existing Flow	MeID VAMP Suppl. Flow	Exch Contr VAMP Suppl. Flow	VAMP Flow (3-day lag)	Desired FERC Pulse	Existing Flow – Adjusted FERC Pulse	VAMP Suppl. Flow	VAMP Flow (2-day lag)	Existing Flow	VAMP Suppl. Flow	Other Suppl. Flow		VAMP Flow (2-day lag)
(cfs)	(cfs)	(cfs)	(TAF)	(cfs)	(cfs)	(cfs)	(cfs)	(cfs)	(cfs)	(cfs)	(cfs)	(cfs)	(cfs)	(cfs)	(cfs)	(cfs)	(cfs)	(cfs)	
					600	600	250			250	150	150		150	746			746	Apr 01
					595	600	250			250	150	150		150	746			746	Apr 02
					590	600	250			250	150	150		150	746			746	Apr 03
2,341				2,341	585	600	250			250	150	150		150	746			746	Apr 04
2,336				2,336	580	600	250			250	150	150		150	746			746	Apr 05
2,331				2,331	575	600	250			250	150	150		150	746			746	Apr 06
2,326				2,326	570	600	250			250	150	150		150	746			746	Apr 07
2,321				2,321	565	600	250			250	150	150		150	746			746	Apr 08
2,316				2,316	560	600	250			250	150	150		150	746			746	Apr 09
2,311				2,311	555	600	250			250	150	150		150	746			746	Apr 10
2,306				2,306	550	600	250	100		350	150	150		150	746			746	Apr 11
2,301				2,301	545	600	250	300	0	550	302	302		302	746			746	Apr 12
2,296	0			2,296	540	600	250	300	0	550	628	660	0	660	746	0	0	746	Apr 13
2,443	100			2,543	535	600	250	220	0	470	628	660	0	660	746	0	0	746	Apr 14
2,796	300	0	0.60	3,096	531	600	250	160	0	410	606	660	0	660	936	0	0	936	Apr 15
2,791	300	0	1.19	3,091	526	600	250	160	0	410	693	730	0	730	936	0	0	936	Apr 16
2,977	220	0	1.63	3,197	522	600	250	160	0	410	693	730	0	730	936	0	0	936	Apr 17
3,042	160	0	1.94	3,202	517	600	250	160	0	410	693	730	0	730	936	0	0	936	Apr 18
3,038	160	0	2.26	3,198	513	600	250	160	0	410	693	730	0	730	936	0	0	936	Apr 19
3,033	160	0	2.58	3,193	508	600	250	160	0	410	693	730	0	730	936	0	0	936	Apr 20
3,029	160	0	2.90	3,189	504	600	250	160	0	410	693	730	0	730	936	0	0	936	Apr 21
3,024	160	0	3.21	3,184	499	600	250	160	0	410	693	730	0	730	936	0	0	936	Apr 22
3,020	160	0	3.53	3,180	495	600	250	0	0	250	693	730	0	730	936	0	0	936	Apr 23
3,015	160	0	3.85	3,175	490	600	250	0	0	250	1,127	1,000	0	1,000	936	0	0	936	Apr 24
3,011	160	0	4.17	3,171	486	600	250	0	0	250	1,127	1,000	0	1,000	936	0	0	936	Apr 25
3,276	0	0	4.17	3,276	481	600	250	0	0	250	1,127	1,000	0	1,000	936	0	0	936	Apr 26
3,272	0	0	4.17	3,272	477	600	250	0	0	250	1,127	1,000	0	1,000	936	0	0	936	Apr 27
3,267	0	0	4.17	3,267	472	600	250	0	0	250	1,127	1,000	0	1,000	936	0	0	936	Apr 28
3,263	0	0	4.17	3,263	467	600	250	0	0	250	1,127	1,000	0	1,000	936	0	0	936	Apr 29
3,258	0	0	4.17	3,258	463	600	250	0	0	250	1,127	1,000	0	1,000	936	0	0	936	Apr 30
3,253	0	0	4.17	3,253	458	600	250	160	0	410	1,127	1,000	0	1,000	936	0	0	936	May 01
3,249	0	0	4.17	3,249	454	600	250	400	0	650	775	800	0	800	936	0	0	936	May 02
3,244	0	0	4.17	3,244	449	600	250	400	0	650	519	570	0	570	936	0	0	936	May 03
3,040	160	0	4.48	3,200	445	600	250	400	0	650	519	570	0	570	936	0	0	936	May 04
2,805	400	0	5.28	3,205	440	600	250	400	0	650	519	570	0	570	936	0	0	936	May 05
2,801	400	0	6.07	3,201	436	600	250	400	0	650	519	570	0	570	936	0	0	936	May 06
2,796	400	0	6.86	3,196	431	600	250	400	0	650	519	570	0	570	936	0	0	936	May 07
2,792	400	0	7.66	3,192	427	600	250	450	0	700	519	570	0	570	936	0	0	936	May 08
2,787	400	0	8.45	3,187	422	600	250	450	0	700	497	530	0	530	936	0	0	936	May 09
2,783	400	0	9.24	3,183	418	600	250	450	0	700	497	530	0	530	936	0	0	936	May 10
2,738	450	0	10.14	3,188	413	600	250	450	0	700	476	530	0	530	936	0	0	936	May 11
2,734	450	0	11.03	3,184	409	600	250	430	0	680	476	530	0	530	936	0	0	936	May 12
2,729	450	0	11.92	3,179	404	600	250	100		350	476	530	0	530	936	0	0	936	May 13
2,725	450	0	12.81	3,175	400	600	250			250	389	389		389	936			936	May 14
2,720	430	0	13.67	3,150	395	600	250			250	302	302		302	936			936	May 15
2,574	100			2,674	391	600	250			250	215	215		215	707			707	May 16
2,483	0			2,483	386	600	250			250	150	150		150	707			707	May 17
2,163	0			2,163	382	600	250			250	150	150		150	707			707	May 18
2,093	0			2,093	377	600	250			250	150	150		150	707			707	May 19
2,089	0			2,089	373	600	250			250	150	150		150	707			707	May 20
2,084	0			2,084	368	600	250			250	150	150		150	707			707	May 21
2,080	0			2,080	364	600	250			250	150	150		150	707			707	May 22
2,075	0			2,075	359	600	250			250	150	150		150	707			707	May 23
2,071	0			2,071	355	600	250			250	150	150		150	707			707	May 24
2,066	0			2,066	350	600	250			250	150	150		150	707			707	May 25
2,062	0			2,062	346	600	250			250	150	150		150	707			707	May 26
2,057	0			2,057	341	600	250			250	150	150		150	707			707	May 27
2,053	0			2,053	337	600	250			250	150	150		150	707			707	May 28
2,048	0			2,048	332	600	250			250	150	150		150	707			707	May 29
2,044	0			2,044	328	600	250			250	150	150		150	707			707	May 30
2,039	0			2,039	323	600	250			250	150	150		150	707			707	May 31
VAMP period																			
2,978	222			3,200	472	600	250	222	0	472	733	732	0	732	924	0	0	924	Avg (cfs):
	13.67							13.67	0.00				0.00			0.00			Suppl. Water (TAF)

Target flow period

Period of desired flow stability

Appendix A-1, Table 3
VAMP DAILY OPERATION PLAN, MARCH 26, 2003 (A) • LOW

Target Flow Period: April 15–May 15 • Flow Target: 3,200 cfs

	San Joaquin River near Vernalis					Merced River at Cressey					Tuolumne River at LaGrange				Stanislaus River below Goodwin				Maintain Priority Flow Level M=Merced T=Tuol. S=Stan.	
	Existing Flow	VAMP Suppl. Flow	Other Suppl. Flow	Cum. VAMP Suppl. Flow	VAMP Flow	SJR above Merced R. (2-day lag)	Ungaged Flow above Vernalis lag)	Existing Flow	MeI'd VAMP Suppl. Flow	Exch Contr VAMP Suppl. Flow	VAMP Flow (3-day lag)	Desired FERC Pulse	Existing Flow – Adjusted FERC Pulse	VAMP Suppl. Flow	VAMP Flow (2-day lag)	Existing Flow	VAMP Suppl. Flow	Other Suppl. Flow		VAMP Flow (2-day lag)
	(cfs)	(cfs)	(cfs)	(TAF)	(cfs)	(cfs)	(cfs)	(cfs)	(cfs)	(cfs)	(cfs)	(cfs)	(cfs)	(cfs)	(cfs)	(cfs)	(cfs)	(cfs)		(cfs)
Apr 01					342	300	250				250	150	150		150	763			763	
Apr 02					339	300	250				250	150	150		150	763			763	
Apr 03					335	300	250				250	150	150		150	763			763	
Apr 04	1,802			1,802	332	300	250				250	150	150		150	763			763	
Apr 05	1,798			1,798	328	300	250				250	150	150		150	763			763	
Apr 06	1,795			1,795	325	300	250				250	150	150		150	763			763	
Apr 07	1,791			1,791	321	300	250				250	150	150		150	763			763	
Apr 08	1,788			1,788	318	300	250				250	150	150		150	763			763	
Apr 09	1,784			1,784	314	300	250				250	150	150		150	763			763	
Apr 10	1,781			1,781	311	300	250				250	150	150		150	763			763	
Apr 11	1,777			1,777	307	300	250	50			300	150	150		150	763			763	
Apr 12	1,774			1,774	304	300	250	299	81		630	400	400		400	763			763	
Apr 13	1,770	0		1,770	300	300	250	299	81		630	800	800	165	965	763	0	0	763	
Apr 14	2,017	50		2,067	297	300	250	299	81		630	1,100	1,100	165	1,265	763	0	0	763	
Apr 15	2,413	545	0	1.08	2,958	293	300	250	299	81	630	1,100	1,100	165	1,265	763	0	0	763	
Apr 16	2,710	545	0	2.16	3,255	290	300	250	299	81	630	1,100	1,100	165	1,265	763	0	0	763	
Apr 17	2,706	545	0	3.24	3,251	286	300	250	299	81	630	1,100	1,100	165	1,265	763	0	0	763	
Apr 18	2,703	545	0	4.32	3,248	283	300	250	304	81	635	1,100	1,100	165	1,265	763	0	0	763	
Apr 19	2,699	545	0	5.40	3,244	279	300	250	304	81	635	1,100	1,100	165	1,265	763	0	0	763	
Apr 20	2,696	545	0	6.49	3,241	276	300	250	304	81	635	1,100	1,100	165	1,265	763	0	0	763	
Apr 21	2,692	550	0	7.58	3,242	272	300	250	304	81	635	1,100	1,100	165	1,265	763	0	0	763	
Apr 22	2,689	550	0	8.67	3,239	269	300	250	304	81	635	1,100	1,100	165	1,265	763	0	0	763	
Apr 23	2,685	550	0	9.76	3,235	265	300	250	304	81	635	1,100	1,100	165	1,265	763	0	0	763	
Apr 24	2,682	550	0	10.85	3,232	262	300	250	304	81	635	1,100	1,100	165	1,265	763	0	0	763	M
Apr 25	2,678	550	0	11.94	3,228	258	300	250	304	81	635	1,100	1,100	165	1,265	763	0	0	763	M
Apr 26	2,675	550	0	13.03	3,225	255	300	250	304	81	635	900	900	165	1,065	763	137	0	900	M
Apr 27	2,671	550	0	14.12	3,221	251	300	250	429	81	760	600	600	165	765	763	537	0	1,300	M, S
Apr 28	2,468	687	0	15.48	3,155	248	300	250	569	81	900	429	429	165	594	763	537	0	1,300	M, S
Apr 29	2,164	1,087	0	17.64	3,251	244	300	250	569	81	900	300	300	160	460	763	537	0	1,300	M, S
Apr 30	1,990	1,212	0	20.04	3,202	241	300	250	569	81	900	300	300	160	460	763	537	0	1,300	M, S
May 01	1,857	1,347	0	22.72	3,204	237	300	250	569	81	900	300	300	160	460	733	567	0	1,300	S
May 02	1,854	1,347	0	25.39	3,201	234	300	250	569	81	900	300	300	160	460	733	567	0	1,300	S
May 03	1,820	1,377	0	28.12	3,197	230	300	250	569	81	900	300	300	160	460	733	567	0	1,300	S
May 04	1,817	1,377	0	30.85	3,194	227	300	250	869	81	1,200	300	300	160	460	733	567	0	1,300	M, S
May 05	1,813	1,377	0	33.58	3,190	223	300	250	869	81	1,200	300	300	160	460	733	367	0	1,100	M
May 06	1,810	1,377	0	36.31	3,187	220	300	250	869	81	1,200	600	600	160	760	733	127	0	860	M
May 07	1,806	1,477	0	39.24	3,283	216	300	250	869	81	1,200	600	600	160	760	733	0	0	733	M
May 08	2,103	1,237	0	41.70	3,340	213	300	250	869	81	1,200	600	600	160	760	733	0	0	733	M
May 09	2,099	1,110	0	43.90	3,209	209	300	250	869	81	1,200	600	600	160	760	733	0	0	733	M
May 10	2,096	1,110	0	46.10	3,206	206	300	250	869	81	1,200	600	600	160	760	733	0	0	733	M
May 11	2,092	1,110	0	48.30	3,202	202	300	250	869	81	1,200	600	600	160	760	733	0	0	733	M
May 12	2,089	1,110	0	50.50	3,199	199	300	250	669	81	1,000	550	550	160	710	733	0	0	733	
May 13	2,085	1,110	0	52.70	3,195	195	300	250	300		550	450	450	160	610	733	0	0	733	
May 14	2,032	1,110	0	54.91	3,142	192	300	250	50		300	389	389		389	733			733	
May 15	1,928	910	0	56.71	2,838	188	300	250			250	302	302		302	733			733	
May 16	1,863	300			2,163	185	300	250			250	215	215		215	733			733	
May 17	1,773	50			1,823	181	300	250			250	150	150		150	733			733	
May 18	1,683	0			1,683	178	300	250			250	150	150		150	733			733	
May 19	1,614	0			1,614	174	300	250			250	150	150		150	733			733	
May 20	1,611	0			1,611	171	300	250			250	150	150		150	733			733	
May 21	1,607	0			1,607	167	300	250			250	150	150		150	733			733	
May 22	1,604	0			1,604	164	300	250			250	150	150		150	733			733	
May 23	1,600	0			1,600	160	300	250			250	150	150		150	733			733	
May 24	1,597	0			1,597	157	300	250			250	150	150		150	733			733	
May 25	1,593	0			1,593	153	300	250			250	150	150		150	733			733	
May 26	1,590	0			1,590	150	300	250			250	150	150		150	733			733	
May 27	1,586	0			1,586	146	300	250			250	150	150		150	733			733	
May 28	1,583	0			1,583	143	300	250			250	150	150		150	733			733	
May 29	1,579	0			1,579	139	300	250			250	150	150		150	733			733	
May 30	1,576	0			1,576	136	300	250			250	150	150		150	733			733	
May 31	1,572	0			1,572	132	300	250			250	150	150		150	733			733	
VAMP period																				
Avg (cfs):	2,278	922		3,200	248	300	250	516	81	847	730	730	163	893	750	163	0	913		
Suppl. Water (TAF)		56.71						31.72	4.98					10.00		10.01				

Target flow period
 Period of desired flow stability

Appendix A-1, Table 4
VAMP DAILY OPERATION PLAN, MARCH 26, 2003 (B) • HIGH

Target Flow Period: April 15–May 15 • Flow Target: 3,200 cfs

San Joaquin River near Vernalis					Merced River at Cressey					Tuolumne River at LaGrange				Stanislaus River below Goodwin				Maintain Priority Flow Level M=Merced T=Tuol.	
Existing Flow	VAMP Suppl. Flow	Other Suppl. Flow	Cum. VAMP Suppl. Flow	VAMP Flow	SJR above Merced R. (2-day lag)	Ungaged Flow above Vernalis	Existing Flow	MeID VAMP Suppl. Flow	Exch Contr VAMP Suppl. Flow	VAMP Flow (3-day lag)	Desired FERC Pulse	Existing Flow – Adjusted FERC Pulse	VAMP Suppl. Flow	VAMP Flow (2-day lag)	Existing Flow	VAMP Suppl. Flow	Other Suppl. Flow		VAMP Flow (2-day lag)
(cfs)	(cfs)	(cfs)	(TAF)	(cfs)	(cfs)	(cfs)	(cfs)	(cfs)	(cfs)	(cfs)	(cfs)	(cfs)	(cfs)	(cfs)	(cfs)	(cfs)	(cfs)	(cfs)	
					548	500	250			250	150	150		150	746			746	Apr 01
					544	500	250			250	150	150		150	746			746	Apr 02
					540	500	250			250	150	150		150	746			746	Apr 03
2,190				2,190	536	500	250			250	150	150		150	746			746	Apr 04
2,186				2,186	532	500	250			250	150	150		150	746			746	Apr 05
2,182				2,182	528	500	250			250	150	150		150	746			746	Apr 06
2,178				2,178	524	500	250			250	150	150		150	746			746	Apr 07
2,174				2,174	520	500	250			250	150	150		150	746			746	Apr 08
2,170				2,170	516	500	250			250	150	150		150	746			746	Apr 09
2,166				2,166	512	500	250			250	150	150		150	746			746	Apr 10
2,162				2,162	508	500	250	50		300	150	150		150	746			746	Apr 11
2,158				2,158	504	500	250	150	0	400	400	400		400	746			746	Apr 12
2,154	0			2,154	500	500	250	150	0	400	800	800	0	800	746	0	0	746	Apr 13
2,400	50			2,450	496	500	250	150	0	400	1,100	1,100	0	1,100	746	0	0	746	Apr 14
2,796	150	0	0.30	2,946	491	500	250	150	0	400	1,100	1,100	0	1,100	746	0	0	746	Apr 15
3,092	150	0	0.60	3,242	487	500	250	150	0	400	1,100	1,100	0	1,100	746	0	0	746	Apr 16
3,087	150	0	0.89	3,237	483	500	250	150	0	400	1,100	1,100	0	1,100	746	0	0	746	Apr 17
3,083	150	0	1.19	3,233	478	500	250	150	0	400	1,100	1,100	0	1,100	746	0	0	746	Apr 18
3,079	150	0	1.49	3,229	474	500	250	150	0	400	1,100	1,100	0	1,100	746	0	0	746	Apr 19
3,074	150	0	1.79	3,224	469	500	250	150	0	400	1,100	1,100	0	1,100	746	0	0	746	Apr 20
3,070	150	0	2.08	3,220	465	500	250	150	0	400	1,100	1,100	0	1,100	746	0	0	746	Apr 21
3,065	150	0	2.38	3,215	461	500	250	200	0	450	1,100	1,100	0	1,100	746	0	0	746	Apr 22
3,061	150	0	2.68	3,211	456	500	250	200	0	450	1,100	1,100	0	1,100	746	0	0	746	Apr 23
3,057	150	0	2.98	3,207	452	500	250	200	0	450	1,100	1,100	0	1,100	746	0	0	746	Apr 24
3,052	200	0	3.37	3,252	448	500	250	250	0	500	1,100	1,100	0	1,100	746	0	0	746	Apr 25
3,048	200	0	3.77	3,248	443	500	250	250	0	500	900	900	0	900	746	0	0	746	Apr 26
3,044	200	0	4.17	3,244	439	500	250	250	0	500	600	600	0	600	950	0	0	950	Apr 27
2,839	250	0	4.66	3,089	435	500	250	250	0	500	429	429	0	429	1,500	0	0	1,500	Apr 28
2,739	250	0	5.16	2,989	430	500	250	250	0	500	300	300	0	300	1,500	0	0	1,500	Apr 29
3,114	250	0	5.65	3,364	426	500	250	250	0	500	300	300	0	300	1,500	0	0	1,500	Apr 30
2,980	250	0	6.15	3,230	421	500	250	250	0	500	300	300	0	300	1,500	0	0	1,500	May 01
2,976	250	0	6.64	3,226	417	500	250	250	0	500	300	300	0	300	1,500	0	0	1,500	May 02
2,971	250	0	7.14	3,221	413	500	250	250	0	500	300	300	0	300	1,500	0	0	1,500	May 03
2,967	250	0	7.64	3,217	408	500	250	700	0	950	300	300	0	300	1,500	0	0	1,500	May 04
2,963	250	0	8.13	3,213	404	500	250	800	0	1,050	300	300	0	300	1,100	0	0	1,100	May 05
2,958	250	0	8.63	3,208	400	500	250	800	0	1,050	600	600	0	600	707	0	0	707	May 06
2,554	700	0	10.02	3,254	395	500	250	800	0	1,050	600	600	0	600	707	0	0	707	May 07
2,457	800	0	11.60	3,257	391	500	250	800	0	1,050	600	600	0	600	707	0	0	707	May 08
2,452	800	0	13.19	3,252	386	500	250	800	0	1,050	600	600	0	600	707	0	0	707	May 09
2,448	800	0	14.78	3,248	382	500	250	800	0	1,050	600	600	0	600	707	0	0	707	May 10
2,443	800	0	16.36	3,243	378	500	250	800	0	1,050	600	600	0	600	707	0	0	707	May 11
2,439	800	0	17.95	3,239	373	500	250	550	0	800	550	550	0	550	707	0	0	707	May 12
2,435	800	0	19.54	3,235	369	500	250	150	0	400	450	450	0	450	707	0	0	707	May 13
2,380	800	0	21.12	3,180	365	500	250			250	389	389		389	707			707	May 14
2,276	550	0	22.21	2,826	361	500	250			250	302	302		302	707			707	May 15
2,211	150			2,361	357	500	250			250	215	215		215	707			707	May 16
2,120	0			2,120	353	500	250			250	150	150		150	707			707	May 17
2,029	0			2,029	349	500	250			250	150	150		150	707			707	May 18
1,960	0			1,960	345	500	250			250	150	150		150	707			707	May 19
1,956	0			1,956	341	500	250			250	150	150		150	707			707	May 20
1,952	0			1,952	337	500	250			250	150	150		150	707			707	May 21
1,948	0			1,948	333	500	250			250	150	150		150	707			707	May 22
1,944	0			1,944	329	500	250			250	150	150		150	707			707	May 23
1,940	0			1,940	325	500	250			250	150	150		150	707			707	May 24
1,936	0			1,936	321	500	250			250	150	150		150	707			707	May 25
1,932	0			1,932	317	500	250			250	150	150		150	707			707	May 26
1,928	0			1,928	313	500	250			250	150	150		150	707			707	May 27
1,924	0			1,924	309	500	250			250	150	150		150	707			707	May 28
1,920	0			1,920	305	500	250			250	150	150		150	707			707	May 29
1,916	0			1,916	301	500	250			250	150	150		150	707			707	May 30
1,912	0			1,912	297	500	250			250	150	150		150	707			707	May 31
VAMP period																			
2,839	361			3,200	435	500	250	361	0	611	730	730	0	730	924	0	0	924	Avg (cfs):
	22.21							22.21	0.00				0.00			0.00			Suppl. Water (TAF)

Target flow period
 Period of desired flow stability

Appendix A-1, Table 5
VAMP DAILY OPERATION PLAN, APRIL 4, 2003

Target Flow Period: April 15–May 15 • Flow Target: 3,200 cfs
bold numbers: observed real time

	San Joaquin River near Vernalis					Merced River at Cressey					Tuolumne River at LaGrange				Stanislaus River below Goodwin				Maintain Priority Flow Level M=Merced T=Tuol. S=Stan.		
	Existing Flow	VAMP Suppl. Flow	Other Suppl. Flow	Cum. VAMP Suppl. Flow	VAMP Flow	SJR above Merced R. (2-day lag)	Un-gaged Flow above Vernalis	Existing Flow	MeID VAMP Suppl. Flow	Exch Contr VAMP Suppl. Flow	VAMP Flow (3-day lag)	Desired FERC Pulse	Existing Flow – Adjusted FERC Pulse	VAMP Suppl. Flow	VAMP Flow (2-day lag)	Existing Flow	Existing Flow (re- shaped)	VAMP Suppl. Flow		Other Suppl. Flow	VAMP Flow (2-day lag)
	(cfs)	(cfs)	(cfs)	(TAF)	(cfs)	(cfs)	(cfs)	(cfs)	(cfs)	(cfs)	(cfs)	(cfs)	(cfs)	(cfs)	(cfs)	(cfs)	(cfs)	(cfs)		(cfs)	(cfs)
Apr 01	1,940				1,940	668	338	225			225	150	181		181	606	606			606	
Apr 02	2,000				2,000	627	311	229			229	150	182		182	604	604			604	
Apr 03	2,040				2,040	616	368	249			249	150	180		180	650	650			650	
Apr 04	2,038				2,038	626	400	250			250	150	150		150	650	650			650	
Apr 05	2,075				2,075	612	400	250			250	150	150		150	650	650			650	
Apr 06	2,075				2,075	598	400	250			250	150	150		150	650	650			650	
Apr 07	2,062				2,062	584	400	250			250	150	150		150	650	650			650	
Apr 08	2,048				2,048	570	400	250			250	150	150		150	650	650			650	
Apr 09	2,034				2,034	556	400	250			250	150	150		150	650	650			650	
Apr 10	2,020				2,020	542	400	250			250	150	150		150	650	650			650	
Apr 11	2,006				2,006	528	400	250	100		350	150	150		150	650	650			650	
Apr 12	1,992				1,992	514	400	250	300	60	610	400	400		400	650	650			650	
Apr 13	1,978	0			1,978	500	400	250	300	60	610	800	800	0	800	763	500	150	0	650	
Apr 14	2,214	100			2,314	496	400	250	300	60	610	1,100	1,100	0	1,100	763	500	150	0	650	
Apr 15	2,450	510	0	1.01	2,960	491	400	250	300	60	610	1,100	1,100	0	1,100	763	500	150	0	650	
Apr 16	2,746	510	0	2.02	3,256	487	400	250	300	60	610	1,100	1,100	0	1,100	763	500	150	0	650	
Apr 17	2,741	510	0	3.03	3,251	483	400	250	300	60	610	1,100	1,100	0	1,100	763	500	150	0	650	
Apr 18	2,737	510	0	4.05	3,247	478	400	250	300	60	610	1,100	1,100	0	1,100	763	500	150	0	650	
Apr 19	2,733	510	0	5.06	3,243	474	400	250	300	60	610	1,100	1,100	0	1,100	763	500	150	0	650	
Apr 20	2,728	510	0	6.07	3,238	469	400	250	300	60	610	1,100	1,100	0	1,100	763	500	150	0	650	
Apr 21	2,724	510	0	7.08	3,234	465	400	250	300	60	610	1,100	1,100	0	1,100	763	500	150	0	650	
Apr 22	2,719	510	0	8.09	3,229	461	400	250	230	60	540	1,100	1,100	0	1,100	763	500	150	0	650	
Apr 23	2,715	510	0	9.10	3,225	456	400	250	130	70	450	1,100	900	0	900	763	500	400	0	900	
Apr 24	2,711	510	0	10.12	3,221	452	400	250	130	70	450	1,100	725	0	725	763	900	300	0	1,200	
Apr 25	2,506	690	0	11.48	3,196	448	400	250	130	70	450	1,100	500	0	500	763	1,250	250	0	1,500	
Apr 26	2,727	500	0	12.48	3,227	443	400	250	130	70	450	900	450	0	450	763	1,250	250	0	1,500	
Apr 27	2,848	450	0	13.37	3,298	439	400	250	130	70	450	600	450	0	450	763	1,250	250	0	1,500	
Apr 28	2,793	450	0	14.26	3,243	435	400	250	130	70	450	429	450	0	450	763	1,250	250	0	1,500	
Apr 29	2,789	450	0	15.15	3,239	430	400	250	130	70	450	300	450	0	450	737	1,250	250	0	1,500	
Apr 30	2,785	450	0	16.05	3,235	426	400	250	130	70	450	300	450	0	450	737	1,250	250	0	1,500	
May 01	2,780	450	0	16.94	3,230	421	400	250	130	70	450	300	450	0	450	737	1,250	250	0	1,500	
May 02	2,776	450	0	17.83	3,226	417	400	250	180	60	490	300	500	0	500	737	1,250	250	0	1,500	
May 03	2,771	450	0	18.72	3,221	413	400	250	500	70	820	300	600	0	600	737	1,100	200	0	1,300	
May 04	2,817	450	0	19.62	3,267	408	400	250	880	70	1,200	300	600	0	600	737	813	192	0	1,005	
May 05	2,763	440	0	20.49	3,203	404	400	250	880	70	1,200	300	600	0	600	737	550	50	0	600	
May 06	2,471	762	0	22.00	3,233	400	400	250	880	70	1,200	600	600	0	600	737	550	50	0	600	
May 07	2,204	1,000	0	23.98	3,204	395	400	250	880	70	1,200	600	600	0	600	737	550	50	0	600	
May 08	2,200	1,000	0	25.97	3,200	391	400	250	880	70	1,200	600	600	0	600	737	550	50	0	600	
May 09	2,195	1,000	0	27.95	3,195	386	400	250	880	70	1,200	600	600	0	600	737	550	50	0	600	
May 10	2,191	1,000	0	29.93	3,191	382	400	250	880	70	1,200	600	600	0	600	737	550	50	0	600	
May 11	2,186	1,000	0	31.92	3,186	378	400	250	880	70	1,200	600	600	0	600	737	550	50	0	600	
May 12	2,182	1,000	0	33.90	3,182	373	400	250	480	70	800	550	600	0	600	737	550	50	0	600	
May 13	2,178	1,000	0	35.88	3,178	369	400	250	250	0	500	450	600	0	600	737	550	50	0	600	
May 14	2,173	1,000	0	37.87	3,173	365	400	250	100	0	350	389	389		389	737	737			737	
May 15	2,169	600	0	39.06	2,769	361	400	250			250	302	302		302	737	737			737	
May 16	2,141	250			2,391	357	400	250			250	215	215		215	737	737			737	
May 17	2,050	100			2,150	353	400	250			250	150	150		150	737	737			737	
May 18	1,959	0			1,959	349	400	250			250	150	150		150	737	737			737	
May 19	1,890	0			1,890	345	400	250			250	150	150		150	737	737			737	
May 20	1,886	0			1,886	341	400	250			250	150	150		150	737	737			737	
May 21	1,882	0			1,882	337	400	250			250	150	150		150	737	737			737	
May 22	1,878	0			1,878	333	400	250			250	150	150		150	737	737			737	
May 23	1,874	0			1,874	329	400	250			250	150	150		150	737	737			737	
May 24	1,870	0			1,870	325	400	250			250	150	150		150	737	737			737	
May 25	1,866	0			1,866	321	400	250			250	150	150		150	737	737			737	
May 26	1,862	0			1,862	317	400	250			250	150	150		150	737	737			737	
May 27	1,858	0			1,858	313	400	250			250	150	150		150	737	737			737	
May 28	1,854	0			1,854	309	400	250			250	150	150		150	737	737			737	
May 29	1,850	0			1,850	305	400	250			250	150	150		150	737	737			737	
May 30	1,846	0			1,846	301	400	250			250	150	150		150	737	737			737	
May 31	1,842	0			1,842	297	400	250			250	150	150		150	737	737			737	
VAMP period																					
Avg (cfs):	2,565	635			3,200	435	400	250													

Appendix A-1, Table 6
VAMP DAILY OPERATION PLAN, APRIL 9, 2003
Target Flow Period: April 15–May 15 • Flow Target: 3,200 cfs
bold numbers: observed real time

San Joaquin River near Vernalis					Merced River at Cressey					Tuolumne River at LaGrange				Stanislaus River below Goodwin					Maintain Priority Flow Level M=Merced T=Tuol. S=Stan.	
Existing Flow	VAMP Suppl. Flow	Other Suppl. Flow	Cum. VAMP Suppl. Flow	VAMP Flow	SJR above Merced R. (2-day lag)	Ungaged Flow above Vernalis	Existing Flow	MelD VAMP Suppl. Flow	Exch Contr VAMP Suppl. Flow	VAMP Flow (3-day lag)	Desired FERC Pulse	Existing Flow – Adjusted FERC Pulse	VAMP Suppl. Flow	VAMP Flow (2-day lag)	Existing Flow (flat)	Existing Flow (re- shaped)	VAMP Suppl. Flow	Other Suppl. Flow		VAMP Flow (2-day lag)
(cfs)	(cfs)	(cfs)	(TAF)	(cfs)	(cfs)	(cfs)	(cfs)	(cfs)	(cfs)	(cfs)	(cfs)	(cfs)	(cfs)	(cfs)	(cfs)	(cfs)	(cfs)	(cfs)	(cfs)	
1,940				1,940	668	338	225			225	150	181		181	650	606			606	Apr 01
2,000				2,000	627	311	229			229	150	182		182	650	604			604	Apr 02
2,040				2,040	616	368	249			249	150	180		180	650	650			650	Apr 03
2,020				2,020	572	382	245			245	150	181		181	650	709			709	Apr 04
2,070				2,077	555	402	250			250	150	183		183	650	709			709	Apr 05
2,010				2,010	546	299	245			245	150	181		181	650	700			700	Apr 06
2,050				2,050	542	358	240			240	150	184		184	650	757			757	Apr 07
1,990				1,990	510	313	250			250	150	150		150	650	800			800	Apr 08
2,028				2,028	498	300	250			250	150	150		150	650	800			800	Apr 09
2,000				2,000	486	300	250			250	150	150		150	650	800			800	Apr 10
1,998				1,998	474	300	250	100		350	150	150		150	650	800			800	Apr 11
1,986				1,986	462	300	250	320	80	650	425	425		425	650	800			800	Apr 12
1,974	0			1,974	450	300	250	320	80	650	700	700	70	770	763	500	150	0	650	Apr 13
2,237	100			2,337	446	300	250	320	80	650	906	1,000	200	1,200	763	500	150	0	650	Apr 14
2,200	620	0	1.23	2,820	442	300	250	320	80	650	906	1,000	200	1,200	763	500	150	0	650	Apr 15
2,496	750	0	2.72	3,246	438	300	250	320	80	650	906	1,000	200	1,200	763	500	150	0	650	Apr 16
2,492	750	0	4.20	3,242	433	300	250	320	80	650	906	1,000	200	1,200	763	500	150	0	650	Apr 17
2,488	750	0	5.69	3,238	429	300	250	320	80	650	906	1,000	200	1,200	763	500	150	0	650	Apr 18
2,483	750	0	7.18	3,233	425	300	250	320	80	650	906	1,000	200	1,200	763	500	150	0	650	Apr 19
2,479	750	0	8.67	3,229	421	300	250	320	80	650	906	1,000	200	1,200	763	500	150	0	650	Apr 20
2,475	750	0	10.16	3,225	417	300	250	320	80	650	906	1,000	200	1,200	763	500	150	0	650	Apr 21
2,471	750	0	11.64	3,221	413	300	250	230	80	560	906	1,000	200	1,200	763	500	150	0	650	Apr 22
2,467	750	0	13.13	3,217	408	300	250	150	80	480	906	780	270	1,050	763	500	400	0	900	Apr 23
2,463	750	0	14.62	3,213	404	300	250	150	80	480	906	580	250	830	763	900	300	0	1,200	Apr 24
2,238	980	0	16.56	3,218	400	300	250	150	80	480	768	430	120	550	763	1,250	250	0	1,500	Apr 25
2,434	780	0	18.11	3,214	396	300	250	150	80	480	580	430	110	540	763	1,250	250	0	1,500	Apr 26
2,630	600	0	19.30	3,230	392	300	250	150	80	480	425	430	110	540	763	1,250	250	0	1,500	Apr 27
2,626	590	0	20.47	3,216	388	300	250	150	80	480	425	430	110	540	763	1,250	250	0	1,500	Apr 28
2,622	590	0	21.64	3,212	383	300	250	150	80	480	425	430	110	540	737	1,250	250	0	1,500	Apr 29
2,618	590	0	22.81	3,208	379	300	250	150	80	480	425	430	110	540	737	1,250	250	0	1,500	Apr 30
2,613	590	0	23.98	3,203	375	300	250	200	80	530	425	430	110	540	737	1,250	250	0	1,500	May 01
2,609	590	0	25.15	3,199	371	300	250	350	100	700	425	430	110	540	737	1,250	250	0	1,500	May 02
2,605	590	0	26.32	3,195	367	300	250	660	100	1,010	425	430	160	590	737	1,100	135	0	1,235	May 03
2,601	640	0	27.59	3,241	363	300	250	960	80	1,290	425	430	160	590	737	813	122	0	935	May 04
2,447	745	0	29.07	3,192	358	300	250	960	80	1,290	425	430	280	710	737	550	50	0	600	May 05
2,156	1,042	0	31.13	3,198	354	300	250	960	80	1,290	562	570	140	710	737	550	50	0	600	May 06
1,888	1,370	0	33.85	3,258	350	300	250	960	80	1,290	562	570	140	710	737	550	50	0	600	May 07
2,024	1,230	0	36.29	3,254	346	300	250	960	80	1,290	562	570	140	710	737	550	50	0	600	May 08
2,020	1,230	0	38.73	3,250	342	300	250	960	80	1,290	562	570	140	710	737	550	50	0	600	May 09
2,016	1,230	0	41.17	3,246	338	300	250	960	80	1,290	562	570	140	710	737	550	50	0	600	May 10
2,012	1,230	0	43.61	3,242	333	300	250	960	80	1,290	562	570	140	710	737	550	50	0	600	May 11
2,008	1,230	0	46.05	3,238	329	300	250	550	80	880	528	530	160	690	737	550	50	0	600	May 12
2,003	1,230	0	48.49	3,233	325	300	250	250	0	500	459	460	160	620	737	550	185	0	735	May 13
1,959	1,250	0	50.97	3,209	321	300	250	100	0	350	417	417		417	737	737			737	May 14
1,885	975	0	52.90	3,860	317	300	250			250	357	357		357	737	737			737	May 15
2,025	250			2,275	313	300	250			250	298	298		298	737	737			737	May 16
1,961	100			2,061	309	300	250			250	150	150		150	737	737			737	May 17
1,898	0			1,898	305	300	250			250	150	150		150	737	737			737	May 18
1,746	0			1,746	301	300	250			250	150	150		150	737	737			737	May 19
1,742	0			1,742	297	300	250			250	150	150		150	737	737			737	May 20
1,738	0			1,738	293	300	250			250	150	150		150	737	737			737	May 21
1,734	0			1,734	289	300	250			250	150	150		150	737	737			737	May 22
1,730	0			1,730	285	300	250			250	150	150		150	737	737			737	May 23
1,726	0			1,726	281	300	250			250	150	150		150	737	737			737	May 24
1,722	0			1,722	277	300	250			250	150	150		150	737	737			737	May 25
1,718	0			1,718	273	300	250			250	150	150		150	737	737			737	May 26
1,714	0			1,714	269	300	250			250	150	150		150	737	737			737	May 27
1,710	0			1,710	265	300	250			250	150	150		150	737	737			737	May 28
1,706	0			1,706	261	300	250			250	150	150		150	737	737			737	May 29
1,702	0			1,702	257	300	250			250	150	150		150	737	737			737	May 30
1,698	0			1,698	253	300	250			250	150	150		150	737	737			737	May 31
VAMP period																				
2,340	860			3,200	388	300	250	454	81	785	652	652	163	814	750	750	163	0	913	Avg (cfs):
	52.90							27.91	5.00				10.00				10.00			Suppl. Water (TAF)

Target flow period

Period of desired flow stability

Appendix A-1, Table 7
VAMP DAILY OPERATION PLAN, APRIL 22, 2003

Target Flow Period: April 15–May 15 • Flow Target: 3,200 cfs
bold numbers: observed real time

	San Joaquin River near Vernalis					Merced River at Cressey					Tuolumne River at LaGrange				Stanislaus River below Goodwin					Maintain Priority Flow Level M=Merced T=Tuol. S=Stan.	
	Existing Flow	VAMP Suppl. Flow	Other Suppl. Flow	Cum. VAMP Suppl. Flow	VAMP Flow	SJR above Merced R. (2-day lag)	Engaged Flow above Vernalis	Existing Flow	MelD VAMP Suppl. Flow	Exch Contr VAMP Suppl. Flow	VAMP Flow (3-day lag)	Desired FERC Pulse	Existing Flow – Adjusted FERC Pulse	VAMP Suppl. Flow	VAMP Flow (2-day lag)	Existing Flow (flat)	Existing Flow (reshap ed)	VAMP Suppl. Flow	Other Suppl. Flow		VAMP Flow (2-day lag)
	(cfs)	(cfs)	(cfs)	(TAF)	(cfs)	(cfs)	(cfs)	(cfs)	(cfs)	(cfs)	(cfs)	(cfs)	(cfs)	(cfs)	(cfs)	(cfs)	(cfs)	(cfs)	(cfs)		(cfs)
Apr 01	1,940			1,950	612	402	225			225	150	181		181	650	606			606		
Apr 02	2,010			2,010	568	377	229			229	150	182		182	650	604			604		
Apr 03	2,050			2,050	548	434	249			249	150	180		180	650	650			650		
Apr 04	2,030			2,030	510	451	245			245	150	181		181	650	709			709		
Apr 05	2,080			2,080	494	473	250			250	150	183		183	650	709			709		
Apr 06	2,020			2,020	484	371	245			245	150	181		181	650	700			700		
Apr 07	2,060			2,060	482	429	240			240	150	184		184	650	757			757		
Apr 08	1,980			1,980	463	365	234			234	150	150		182	650	800			801		
Apr 09	1,930			1,930	442	262	235			235	150	150		183	650	800			801		
Apr 10	1,880			1,880	410	194	239			239	150	150		182	650	800			802		
Apr 11	1,920			1,920	385	260	250	104		354	150	150		295	650	800			808		
Apr 12	2,000			2,000	329	371	250	276	80	606	425	425		452	650	800			805		
Apr 13	2,290	0		2,290	277	563	250	307	80	637	700	700	138	838	763	500	232	0	732		
Apr 14	2,494	136		2,630	290	690	250	324	80	654	906	1,000	220	1,220	763	500	147	0	647		
Apr 15	2,133	726	0	1.44	2,859	325	406	250	308	80	638	906	1,000	240	1,240	763	500	149	0	649	
Apr 16	2,266	754	0	2.94	3,020	323	226	250	348	80	678	906	1,000	230	1,230	763	500	149	0	649	
Apr 17	2,317	793	0	4.51	3,110	327	242	250	343	80	673	906	1,000	230	1,230	763	500	149	0	649	
Apr 18	2,423	767	0	6.03	3,190	374	350	250	345	80	675	906	1,000	250	1,250	763	500	149	0	649	
Apr 19	2,403	807	0	7.63	3,210	392	326	250	340	80	670	906	1,000	250	1,250	763	500	149	0	649	
Apr 20	2,558	822	0	9.26	3,380	378	434	250	333	80	663	906	1,000	260	1,260	763	500	152	0	652	
Apr 21	2,686	824	0	10.90	3,510	362	544	250	321	80	651	906	1,000	250	1,250	763	500	152	0	652	
Apr 22	2,588	832	0	12.55	3,420	413	460	250	230	80	560	906	1,000	100	1,100	763	500	150	0	650	
Apr 23	2,412	815	0	14.16	3,227	408	300	250	150	80	480	906	780	170	950	763	500	400	0	900	
Apr 24	2,463	651	0	15.45	3,114	404	300	250	150	80	480	906	580	150	730	763	900	300	0	1,200	M
Apr 25	2,238	880	0	17.20	3,118	400	300	250	150	80	480	768	430	120	550	763	1,250	250	0	1,500	M,S
Apr 26	2,434	680	0	18.55	3,114	396	300	250	150	80	480	580	430	110	540	763	1,250	250	0	1,500	M,S
Apr 27	2,630	600	0	19.74	3,230	392	300	250	150	80	480	425	430	110	540	763	1,250	250	0	1,500	M,S
Apr 28	2,626	590	0	20.91	3,216	388	300	250	150	80	480	425	430	110	540	763	1,250	250	0	1,500	M,S
Apr 29	2,622	590	0	22.08	3,212	383	300	250	150	80	480	425	430	110	540	737	1,250	250	0	1,500	M,S
Apr 30	2,618	590	0	23.25	3,208	379	300	250	150	80	480	425	430	110	540	737	1,250	250	0	1,500	M,S
May 01	2,613	590	0	24.42	3,203	375	300	250	200	80	530	425	430	110	540	737	1,250	250	0	1,500	S
May 02	2,609	590	0	25.59	3,199	371	300	250	350	100	700	425	430	110	540	737	1,250	250	0	1,500	S
May 03	2,605	590	0	26.76	3,195	367	300	250	660	100	1,010	425	430	160	590	737	1,100	135	0	1,235	
May 04	2,601	640	0	28.03	3,241	363	300	250	960	80	1,290	425	430	160	590	737	813	122	0	935	M
May 05	2,447	745	0	29.51	3,192	358	300	250	960	80	1,290	425	430	280	710	737	550	50	0	600	M
May 06	2,156	1,042	0	31.57	3,198	354	300	250	960	80	1,290	562	570	140	710	737	550	50	0	600	M
May 07	1,888	1,370	0	34.29	3,258	350	300	250	960	80	1,290	562	570	140	710	737	550	50	0	600	M
May 08	2,024	1,230	0	36.73	3,254	346	300	250	960	80	1,290	562	570	140	710	737	550	50	0	600	M
May 09	2,020	1,230	0	39.17	3,250	342	300	250	960	80	1,290	562	570	140	710	737	550	50	0	600	M
May 10	2,016	1,230	0	41.61	3,246	338	300	250	960	80	1,290	562	570	140	710	737	550	50	0	600	M
May 11	2,012	1,230	0	44.05	3,242	333	300	250	960	80	1,290	562	570	140	710	737	550	50	0	600	M
May 12	2,008	1,230	0	46.49	3,238	329	300	250	550	80	880	528	530	160	690	737	550	50	0	600	
May 13	2,003	1,230	0	48.93	3,233	325	300	250	250	0	500	459	460	160	620	737	550	185	0	735	
May 14	1,959	1,250	0	51.41	3,209	321	300	250	100	0	350	417	417		417	737	737			737	
May 15	1,885	975	0	53.34	2,860	317	300	250			250	357	357		357	737	737			737	
May 16	2,025	250			2,275	313	300	250			250	298	298		298	737	737			737	
May 17	1,961	100			2,061	309	300	250			250	150	150		150	737	737			737	
May 18	1,898	0			1,898	305	300	250			250	150	150		150	737	737			737	
May 19	1,746	0			1,746	301	300	250			250	150	150		150	737	737			737	
May 20	1,742	0			1,742	297	300	250			250	150	150		150	737	737			737	
May 21	1,738	0			1,738	293	300	250			250	150	150		150	737	737			737	
May 22	1,734	0			1,734	289	300	250			250	150	150		150	737	737			737	
May 23	1,730	0			1,730	285	300	250			250	150	150		150	737	737			737	
May 24	1,726	0			1,726	281	300	250			250	150	150		150	737	737			737	
May 25	1,722	0			1,722	277	300	250			250	150	150		150	737	737			737	
May 26	1,718	0			1,718	273	300	250			250	150	150		150	737	737			737	
May 27	1,714	0			1,714	269	300	250			250	150	150		150	737	737			737	
May 28	1,710	0			1,710	265	300	250			250	150	150		150	737	737			737	
May 29	1,706	0			1,706	261	300	250			250	150	150		150	737	737			737	
May 30	1,702	0			1,702	257	300	250			250	150	150		150	737	737			737	
May 31	1,698	0			1,698	253	300	250			250	150	150		150	737	737			737	
VAMP period																					
Avg (cfs):	2,331	868		3,199	360	319	250	455	81	787	652	652	166	817	750	750	165	0	916		
Suppl. Water (TAF)		53.34						28.00	5.00				10.19					10.16			

Target flow period
 Period of desired flow stability

Appendix A-1, Table 8
VAMP DAILY OPERATION PLAN, APRIL 30, 2003
Target Flow Period: April 15–May 15 • Flow Target: 3,200 cfs
bold numbers: observed real time

San Joaquin River near Vernalis							Merced River at Cressey				Tuolumne River at LaGrange				Stanislaus River below Goodwin					
Existing Flow	VAMP Suppl. Flow	Other Suppl. Flow	Cum. VAMP Suppl. Flow	VAMP Flow	SJR above Merced R. (2-day lag)	Unengaged Flow above Vernalis	Existing Flow	MelD VAMP Suppl. Flow	Exch Contr VAMP Suppl. Flow	VAMP Flow (3-day lag)	Desired FERC Pulse	Existing Flow – Adjusted FERC Pulse	VAMP Suppl. Flow	VAMP Flow (2-day lag)	Existing Flow (flat)	Existing Flow (re-shaped)	VAMP Suppl. Flow	Other Suppl. Flow	VAMP Flow (2-day lag)	Maintain Priority Flow Level M=Merced T=Tuol. S=Stan.
(cfs)	(cfs)	(cfs)	(TAF)	(cfs)	(cfs)	(cfs)	(cfs)	(cfs)	(cfs)	(cfs)	(cfs)	(cfs)	(cfs)	(cfs)	(cfs)	(cfs)	(cfs)	(cfs)	(cfs)	
1,940				1,950	612	402	225			225	150	181		181	650	606			606	Apr 01
2,010				2,010	568	377	229			229	150	182		182	650	604			604	Apr 02
2,050				2,050	548	434	249			249	150	180		180	650	650			650	Apr 03
2,030				2,030	510	451	245			245	150	181		181	650	709			709	Apr 04
2,080				2,080	494	473	250			250	150	183		182	650	709			709	Apr 05
2,020				2,020	484	371	245			245	150	181		181	650	700			700	Apr 06
2,060				2,060	482	429	240			240	150	184		184	650	757			757	Apr 07
1,980				1,980	463	365	234			234	150	150		182	650	800			801	Apr 08
1,930				1,930	442	262	235			235	150	150		183	650	800			801	Apr 09
1,880				1,880	410	194	239			239	150	150		182	650	800			802	Apr 10
1,920				1,920	385	260	250	104		354	150	150		303	650	800			808	Apr 11
2,000				2,000	329	371	250	276	80	606	425	425		472	650	800			805	Apr 12
2,290	0			2,290	277	563	250	307	80	637	700	700	191	891	763	500	232	0	732	Apr 13
2,494	136			2,630	290	690	250	324	80	654	906	1,000	300	1,300	763	500	147	0	647	Apr 14
2,133	779	0	1.55	2,859	325	406	250	308	80	638	906	1,000	310	1,310	763	500	149	0	649	Apr 15
2,266	834	0	3.20	3,020	323	226	250	348	80	678	906	1,000	310	1,310	763	500	149	0	649	Apr 16
2,317	863	0	4.91	3,110	327	242	250	343	80	673	906	1,000	310	1,310	763	500	149	0	649	Apr 17
2,423	847	0	6.59	3,190	374	350	250	345	80	675	906	1,000	330	1,330	763	500	149	0	649	Apr 18
2,403	887	0	8.35	3,210	392	326	250	340	80	670	906	1,000	330	1,330	763	500	149	0	649	Apr 19
2,558	902	0	10.14	3,380	378	434	250	333	80	663	906	1,000	340	1,340	763	500	152	0	652	Apr 20
2,686	904	0	11.93	3,510	362	544	250	321	80	651	906	1,000	330	1,330	763	500	152	0	652	Apr 21
2,508	912	0	13.74	3,420	348	380	250	241	80	571	906	1,000	270	1,270	763	500	152	0	652	Apr 22
2,425	895	0	15.52	3,320	325	313	250	177	80	507	906	780	250	1,030	763	500	281	0	781	Apr 23
2,227	823	0	17.15	3,050	311	129	250	163	80	493	906	580	238	818	763	900	321	0	1,221	M
2,228	852	0	18.84	3,080	288	373	250	182	80	512	768	430	176	606	763	1,250	262	0	1,512	M,S
2,394	816	0	20.46	3,210	313	353	250	187	80	517	580	430	149	579	763	1,250	251	0	1,501	M,S
2,569	681	0	21.81	3,250	316	351	250	182	80	512	425	430	151	581	763	1,250	253	0	1,503	M,S
2,668	662	0	23.12	3,330	308	425	250	196	80	526	425	430	153	583	763	1,250	256	0	1,506	M,S
2,759	671	0	24.45	3,430	320	513	250	180	80	510	425	430	130	560	737	1,250	253	0	1,503	M,S
2,638	671	0	25.78	3,309	379	400	250	150	80	480	425	430	110	540	737	1,250	250	0	1,500	M,S
2,550	659	0	27.09	3,209	375	300	250	200	80	530	425	430	110	540	737	1,250	250	0	1,500	S
2,609	620	0	28.32	3,229	371	300	250	350	100	700	425	430	110	540	737	1,250	250	0	1,500	S
2,605	590	0	29.49	3,195	367	300	250	660	100	1,010	425	430	110	540	737	1,100	135	0	1,235	May 02
2,601	640	0	30.76	3,241	363	300	250	1,000	80	1,330	425	430	110	540	737	813	122	0	935	M
2,447	695	0	32.14	3,142	358	300	250	1,000	80	1,330	425	430	110	540	737	550	50	0	600	M
2,156	992	0	34.11	3,148	354	300	250	1,000	80	1,330	562	570	30	600	737	550	50	0	600	M
1,888	1,240	0	36.57	3,128	350	300	250	1,000	80	1,330	425	570	30	600	737	550	50	0	600	M
2,024	1,160	0	38.87	3,184	346	300	250	1,000	80	1,330	425	570	30	600	737	550	50	0	600	M
2,020	1,160	0	41.17	3,180	342	300	250	1,000	80	1,330	425	570	30	600	737	550	50	0	600	M
2,016	1,160	0	43.47	3,176	338	300	250	1,000	80	1,330	425	570	30	600	737	550	50	0	600	M
2,012	1,160	0	45.77	3,172	333	300	250	1,000	80	1,330	425	570	30	600	737	550	50	0	600	M
2,008	1,160	0	48.07	3,168	329	300	250	550	80	880	528	530	30	560	737	550	50	0	600	May 10
2,003	1,160	0	50.37	3,163	325	300	250	250	0	500	459	460	30	490	737	550	185	0	735	May 12
1,959	1,160	0	52.67	3,119	321	300	250	100	0	350	417	417		417	737	737			737	May 14
1,885	845	0	54.35	2,730	317	300	250			250	357	357		357	737	737			737	May 15
2,025	250			2,275	313	300	250			250	298	298		298	737	737			737	May 16
1,961	100			2,061	309	300	250			250	150	150		150	737	737			737	May 17
1,898	0			1,898	305	300	250			250	150	150		150	737	737			737	May 18
1,746	0			1,746	301	300	250			250	150	150		150	737	737			737	May 19
1,742	0			1,742	297	300	250			250	150	150		150	737	737			737	May 20
1,738	0			1,738	293	300	250			250	150	150		150	737	737			737	May 21
1,734	0			1,734	289	300	250			250	150	150		150	737	737			737	May 22
1,730	0			1,730	285	300	250			250	150	150		150	737	737			737	May 23
1,726	0			1,726	281	300	250			250	150	150		150	737	737			737	May 24
1,722	0			1,722	277	300	250			250	150	150		150	737	737			737	May 25
1,718	0			1,718	273	300	250			250	150	150		150	737	737			737	May 26
1,714	0			1,714	269	300	250			250	150	150		150	737	737			737	May 27
1,710	0			1,710	265	300	250			250	150	150		150	737	737			737	May 28
1,706	0			1,706	261	300	250			250	150	150		150	737	737			737	May 29
1,702	0			1,702	257	300	250			250	150	150		150	737	737			737	May 30
1,698	0			1,698	253	300	250			250	150	150		150	737	737			737	May 31
VAMP period																				
2,322	884			3,189	339	331	250	473	81	804	652	652	167	818</						

Appendix A–2, Table 1
2003 VERNALIS ADAPTIVE MANAGEMENT PLAN (VAMP)

Final Accounting of Supplemental Water Contributions

Target Flow Period: April 15–May 15 • Target Flow: 3,200 cfs

	Merced R. at Cressey (3 Day Travel Time to Vernalis)			Tuolumne R. below LaGrange Dam (2 Day Travel Time to Vernalis)			Stanislaus R. below Goodwin Dam (2 Day Travel Time to Vernalis)			SJRECWA (3 Day)	San Joaquin River at Vernalis		
	Existing Flow	Observed Flow	VAMP Suppl. Water	Existing Flow	Observed Flow	VAMP Suppl. Water	Existing Flow	Observed Flow	VAMP Suppl. Water	VAMP Suppl. Water	Existing Flow	Observed Flow	VAMP Suppl. Water
	(cfs)	(cfs)	(cfs)	(cfs)	(cfs)	(cfs)	(cfs)	(cfs)	(cfs)	(cfs)	(cfs)	(cfs)	(cfs)
Apr 01	228	228		181	181		606	606			1,950	1,950	
Apr 02	232	232		182	182		604	604			2,010	2,010	
Apr 03	253	253		180	180		650	650			2,050	2,050	
Apr 04	252	252		181	181		709	709			2,030	2,030	
Apr 05	259	259		182	182		709	709			2,080	2,080	
Apr 06	257	257		181	181		700	700			2,010	2,010	
Apr 07	253	253		184	184		757	757			2,050	2,050	
Apr 08	250	250		182	182		801	801			1,970	1,970	
Apr 09	254	254		183	183		801	801			1,920	1,920	
Apr 10	261	261		182	182		802	802			1,850	1,850	
Apr 11	250	386		303	303		808	808			1,880	1,880	
Apr 12	250	649	399	472	472		805	805	0		1,980	1,980	
Apr 13	250	681	431	700	891	191	500	732	232	0	2,260	2,260	
Apr 14	250	701	451	1,000	1,300	300	500	647	147	0	2,610	2,610	
Apr 15	250	688	438	1,000	1,310	310	500	649	149	0	2,017	2,839	822
Apr 16	250	719	469	1,000	1,310	310	500	649	149	0	2,132	3,010	878
Apr 17	250	702	452	1,000	1,310	310	500	649	149	0	2,190	3,100	910
Apr 18	250	693	443	1,000	1,330	330	500	649	149	0	2,283	3,180	897
Apr 19	250	678	428	1,000	1,330	330	500	649	149	0	2,272	3,200	928
Apr 20	250	658	408	1,000	1,340	340	500	652	152	0	2,439	3,370	931
Apr 21	250	637	387	1,000	1,330	330	500	652	152	0	2,578	3,500	922
Apr 22	250	559	309	1,000	1,270	270	500	652	152	0	2,490	3,410	920
Apr 23	250	502	252	780	1,030	250	500	781	281	0	2,420	3,310	890
Apr 24	250	495	245	580	818	238	900	1,221	321	0	2,241	3,050	809
Apr 25	250	519	269	430	602	172	1,250	1,512	262	0	2,230	3,070	840
Apr 26	250	527	277	430	574	144	1,250	1,501	251	0	2,389	3,200	811
Apr 27	250	527	277	430	573	143	1,250	1,503	253	0	2,561	3,240	679
Apr 28	250	547	297	430	575	145	1,250	1,506	256	0	2,656	3,320	664
Apr 29	250	536	286	430	551	121	1,250	1,503	253	0	2,747	3,420	673
Apr 30	250	549	299	430	522	92	1,250	1,502	252	0	2,642	3,320	678
May 01	250	598	348	430	524	94	1,250	1,502	252	0	2,609	3,280	671
May 02	250	846	596	430	525	95	1,250	1,506	256	0	2,630	3,260	630
May 03	250	1,190	940	430	525	95	1,100	1,268	168	0	2,685	3,330	645
May 04	250	1,490	1,240	430	524	94	813	950	137	0	2,790	3,489	699
May 05	250	1,490	1,240	430	524	94	550	598	48	0	2,600	3,459	859
May 06	250	1,500	1,250	570	589	19	550	600	50	0	2,149	3,320	1,171
May 07	250	1,530	1,280	570	585	15	550	604	54	0	1,828	3,210	1,382
May 08	250	1,520	1,270	570	583	13	550	600	50	0	1,941	3,250	1,309
May 09	250	1,520	1,270	570	574	4	550	607	57	0	1,981	3,300	1,319
May 10	250	1,520	1,270	570	577	7	550	603	53	0	1,947	3,290	1,343
May 11	250	1,420	1,170	570	579	9	550	603	53	0	2,059	3,390	1,331
May 12	250	847	597	530	542	12	550	603	53	0	2,070	3,400	1,330
May 13	250	524		460	488	28	550	691	141		1,898	3,230	1,332
May 14	250	407		407	407		741	741			1,645	2,880	1,235
May 15	250	315		353	353		733	733			1,884	2,650	766
May 16	254	292		306	306		751	751			2,216	2,490	
May 17	249	249		228	228		914	914			2,183	2,340	
May 18	257	257		185	185		1,004	1,004			2,225	2,290	
May 19	252	252		184	184		998	998			2,332	2,370	
May 20	235	235		348	348		1,004	1,004			2,250	2,250	
May 21	236	236		563	563		772	772			2,110	2,110	
May 22	233	233		565	565		599	599			2,120	2,120	
May 23	227	227		569	569		603	603			2,070	2,070	
May 24	196	196		567	567		606	606			2,060	2,060	
May 25	228	228		568	568		605	605			2,080	2,080	
May 26	230	230		568	568		604	604			2,150	2,150	
May 27	243	243		569	569		740	740			2,050	2,050	
May 28	215	215		566	566		976	976			1,950	1,950	
May 29	196	196		512	512		1,046	1,046			2,039	2,039	
May 30	188	188		323	323		1,051	1,051			2,160	2,160	
May 31	189	189		266	266		1,051	1,051			2,190	2,190	
Total Supplemental Water (acre-feet):			38,257			9,729			10,078	0			58,065
Target Flow Period Average											2,290	3,235	

Observed Flow Sources (best available data as of July 31, 2003):

Merced River at Cressey (CA DWR B05155): California DWR, San Joaquin District • Tuolumne River below LaGrange Dam near LaGrange (USGS 11289650):

USGS Stanislaus River below Goodwin Dam: USBR, Goodwin Reservoir Daily Operations Report –OID/SSJID/Tri-Dams • San Joaquin River near Vernalis (USGS 11303500): USGS

A-3. COMPARISON OF “REAL-TIME” AND PROVISIONAL FLOWS

Merced River Near Cressey

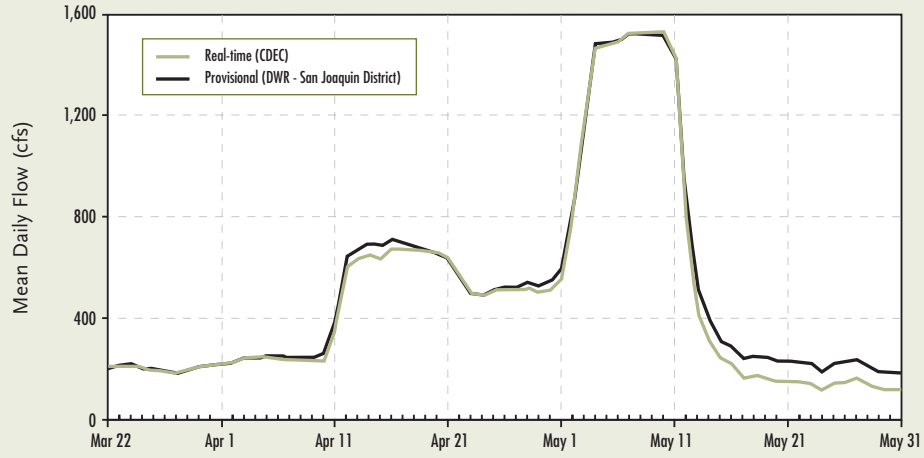

Merced River Near Stevinson

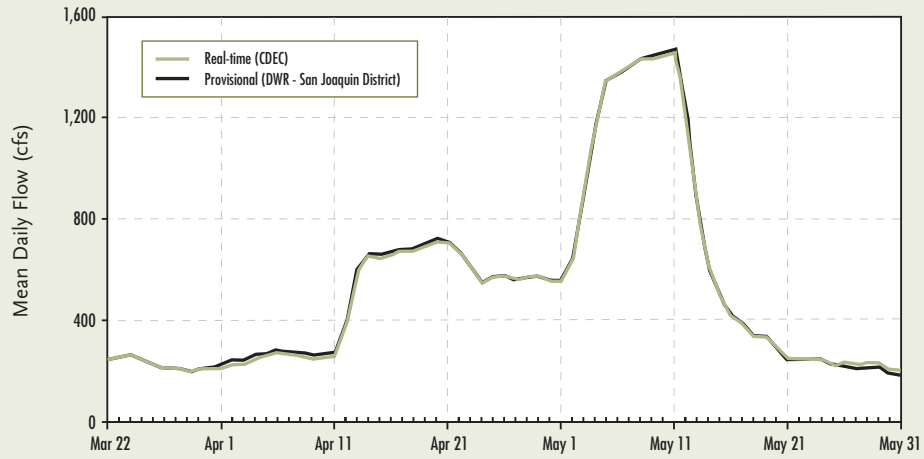

San Joaquin River Above Merced River

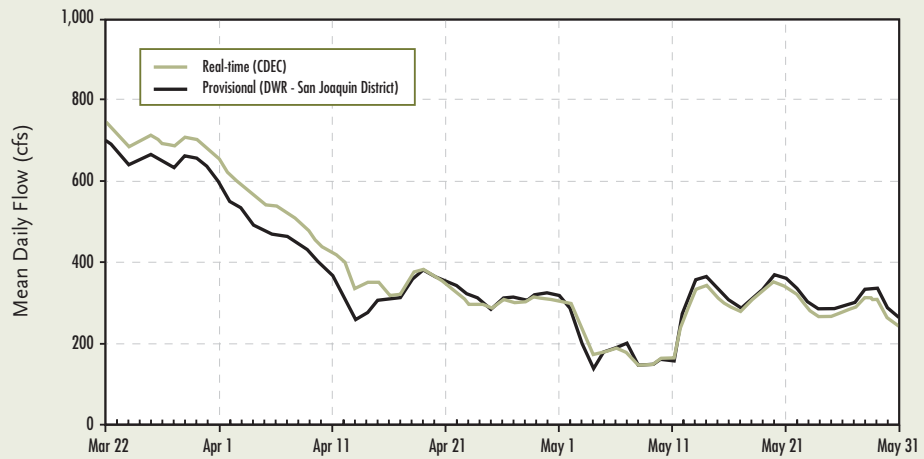

A-3. COMPARISON OF "REAL-TIME" AND PROVISIONAL FLOWS

San Joaquin River near Newman

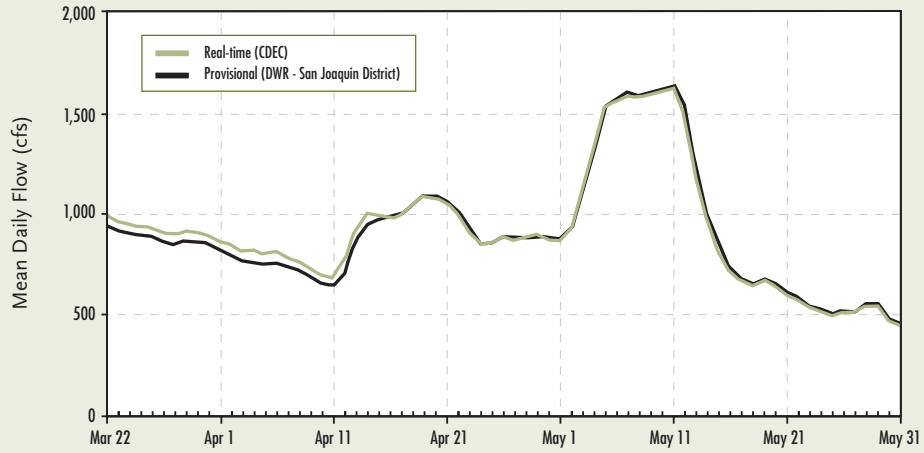

Tuolumne River below LaGrange Dam

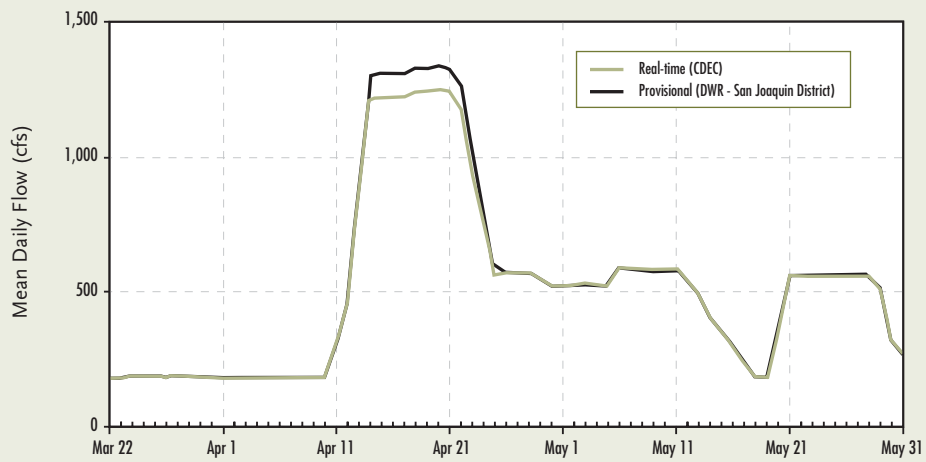

A-3. COMPARISON OF "REAL-TIME" AND PROVISIONAL FLOWS

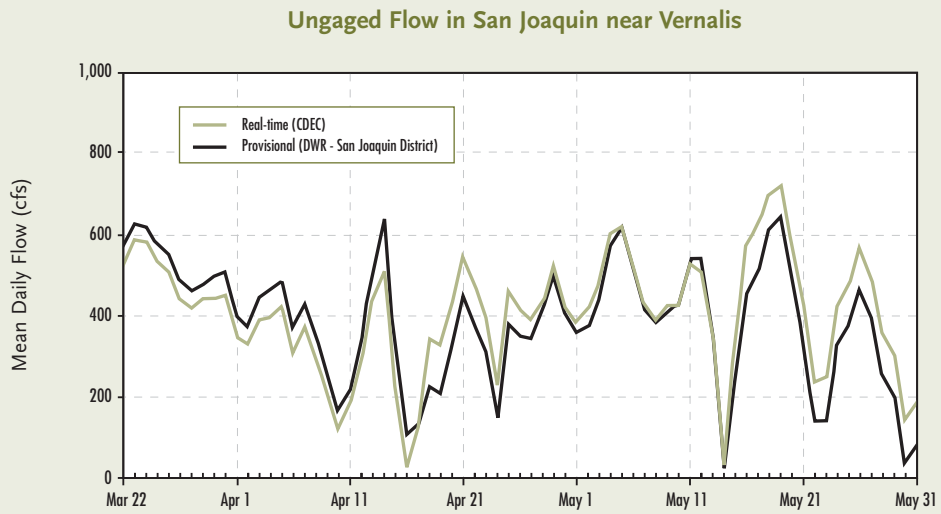
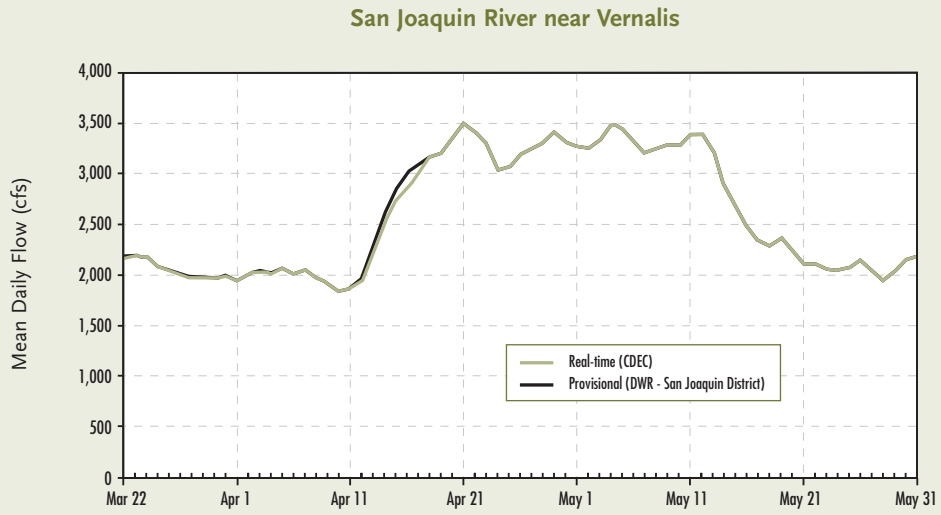

Appendix A-4
FLOW IN SAN JOAQUIN RIVER AND OLD RIVER NEAR HORB

All values in cfs

	San Joaquin River near Vernalis (1)	Old River at Head (2)	San Joaquin River below Old River (3)	Through HORB Culverts (4)	Estimated HORB Seepage (5)
Mar 01	2,020	1,081	939		
Mar 02	2,050	1,032	1,018		
Mar 03	2,120	1,102	1,018		
Mar 04	2,130	1,005	1,125		
Mar 05	2,050	1,007	1,043		
Mar 06	2,070	974	1,096		
Mar 07	2,130	1,046	1,084		
Mar 08	2,210	938	1,272		
Mar 09	2,240	916	1,324		
Mar 10	2,260	945	1,315		
Mar 11	2,200	969	1,231		
Mar 12	2,200	1,016	1,184		
Mar 13	2,280	1,101	1,179		
Mar 14	2,270	1,070	1,200		
Mar 15	2,470	1,179	1,291		
Mar 16	2,620	1,224	1,396		
Mar 17	2,540	1,292	1,248		
Mar 18	2,500	1,302	1,198		
Mar 19	2,420	1,138	1,282		
Mar 20	2,320	1,095	1,225		
Mar 21	2,230	1,037	1,193		
Mar 22	2,180	1,011	1,169		
Mar 23	2,200	992	1,208		
Mar 24	2,180	1,032	1,148		
Mar 25	2,100	973	1,127		
Mar 26	2,060	1,020	1,040		
Mar 27	2,010	1,135	875		
Mar 28	1,980	1,039	941		
Mar 29	1,980	879	1,101		
Mar 30	1,970	953	1,017		
Mar 31	2,000	932	1,068		
Apr 01	1,950	1,017	933		
Apr 02	2,010	820	1,190		
Apr 03	2,050	846	1,204		
Apr 04	2,030	838	1,192		
Apr 05	2,080	862	1,218		
Apr 06	2,010	832	1,178		
Apr 07	2,050	709	1,341		
Apr 08	1,970	649	1,321		
Apr 09	1,920	507	1,413		
Apr 10	1,850	617	1,233		
Apr 11	1,880	368	1,512		
Apr 12	1,970	262	1,708		
Apr 13	2,260	379	1,881		
Apr 14	2,600	415	2,185	138	277
Apr 15	2,839	354	2,485	153	201
Apr 16	3,000	388	2,612	186	202
Apr 17	3,090	467	2,623	198	269
Apr 18	3,160	427	2,733	195	232
Apr 19	3,180	469	2,711	192	277
Apr 20	3,350	459	2,891	186	273
Apr 21	3,469	409	3,060	174	235
Apr 22	3,390	280	3,110	180	100
Apr 23	3,300	291	3,009	180	111
Apr 24	3,050	207	2,843	168	39
Apr 25	3,070	179	2,891	177	2
Apr 26	3,200	270	2,930	177	93
Apr 27	3,240	284	2,956	177	107
Apr 28	3,320	218	3,102	165	53
Apr 29	3,420	285	3,135	171	114
Apr 30	3,320	322	2,998	174	148

	San Joaquin River near Vernalis (1)	Old River at Head (2)	San Joaquin River below Old River (3)	Through HORB Culverts (4)	Estimated HORB Seepage (5)
	3,280	258	3,022	168	90
	3,260	189	3,071	168	21
	3,330	192	3,138	162	30
	3,489	326	3,163	168	158
	3,459	341	3,118	177	164
	3,320	354	2,966	168	186
	3,210	325	2,885	159	166
	3,240	388	2,852	156	232
	3,290	360	2,930	171	189
	3,270	334	2,936	171	163
	3,370	305	3,065	171	134
	3,360	316	3,044	171	145
	3,190	359	2,831	171	188
	2,829	434	2,395	162	272
	2,600	389	2,211	159	230
	2,430	372	2,058	153	219
	2,270	385	1,885		
	2,210	373	1,837		
	2,290	661	1,629		
	2,160	462	1,698		
	2,020	432	1,588		
	2,010	500	1,510		
	1,960	603	1,357		
	1,940	721	1,219		
	1,950	756	1,194		
	2,020	675	1,345		
	1,900	613	1,287		
	1,810	663	1,147		
	1,890	822	1,068		
	2,000	945	1,055		
	2,020	906	1,114		
	2,000	881	1,119		
	1,980	858	1,122		
	1,920	957	963		
	1,840	1,048	792		
	1,870	999	871		
	1,920	1,025	895		
	2,070	1,067	1,003		
	2,150	1,026	1,124		
	2,200	1,086	1,114		
	2,130	956	1,174		
	2,080	742	1,338		
	1,990	554	1,436		
	1,980	678	1,302		
	2,010	650	1,360		
	2,150	620	1,530		
	2,200	663	1,537		
	2,150	683	1,467		
	2,120	738	1,382		
	2,030	622	1,408		
	1,970	635	1,335		
	1,960	545	1,415		
	2,000	473	1,527		
	2,020	515	1,505		
	2,020	501	1,519		
	1,990	507	1,483		
	1,980	529	1,451		
	2,039	599	1,440		
	2,050	604	1,446		
	2,090	649	1,441		
	2,100	652	1,448		

May 01
May 02
May 03
May 04
May 05
May 06
May 07
May 08
May 09
May 10
May 11
May 12
May 13
May 14
May 15
May 16
May 17
May 18
May 19
May 20
May 21
May 22
May 23
May 24
May 25
May 26
May 27
May 28
May 29
May 30
May 31
Jun 01
Jun 02
Jun 03
Jun 04
Jun 05
Jun 06
Jun 07
Jun 08
Jun 09
Jun 10
Jun 11
Jun 12
Jun 13
Jun 14
Jun 15
Jun 16
Jun 17
Jun 18
Jun 19
Jun 20
Jun 21
Jun 22
Jun 23
Jun 24
Jun 25
Jun 26
Jun 27
Jun 28
Jun 29
Jun 30

VAMP target flow period highlighted

- (1) USGS provisional data as of 11/6/2003
- (2) DWR Acoustic Doppler Current Meter located 840 ft. downstream of HORB
- (3) (1)-(2)
- (4) Three times the measured flow in HORB Culvert #4
- (5) (2)-(4)



APPENDIX B

Fall Water Transfer & Delivery Information

B-1. MERCED IRRIGATION DISTRICT
SJRA Fall 2003 Water Transfer · Daily Summary

SCHEDULED				
	BASE FLOW – Merced River at Cressey	SJRA Transfer Water	TARGET FLOW – Merced River at Cressey	SJRA Transfer Water Cumulative Volume
	(cfs)	(cfs)	(cfs)	(acre-feet)
Oct 01	30	70	100	139
Oct 02	30	70	100	278
Oct 03	30	125	155	526
Oct 04	30	125	155	774
Oct 05	30	125	155	1,021
Oct 06	30	125	155	1,269
Oct 07	30	125	155	1,517
Oct 08	30	125	155	1,765
Oct 09	30	125	155	2,013
Oct 10	30	125	155	2,261
Oct 11	30	125	155	2,509
Oct 12	30	125	155	2,757
Oct 13	30	125	155	3,005
Oct 14	30	125	155	3,253
Oct 15	30	125	155	3,501
Oct 16	85	125	210	3,749
Oct 17	85	185	270	4,116
Oct 18	85	315	400	4,740
Oct 19	85	515	600	5,762
Oct 20	85	515	600	6,783
Oct 21	85	515	600	7,805
Oct 22	85	515	600	8,826
Oct 23	85	515	600	9,848
Oct 24	85	315	400	10,473
Oct 25	85	215	300	10,899
Oct 26	85	135	220	11,167
Oct 27	85	135	220	11,435
Oct 28	85	135	220	11,702
Oct 29	85	135	220	11,970
Oct 30	85	135	220	12,238
Oct 31	85	135	220	12,506

B-2. MERCED IRRIGATION DISTRICT
SJRA Fall 2002 Water Transfer · Daily Summary (FINAL)

	SCHEDULED				OBSERVED		
	BASE FLOW – Merced River at Cressey	SJRA Transfer Water	SJRA Transfer Water Cumulative Volume	TARGET FLOW – Merced River at Cressey	FLOW – Merced River at Cressey	SJRA Transfer Water	SJRA Transfer Water Cumulative Volume
	(cfs)	(cfs)	(acre-feet)	(cfs)	(cfs)	(cfs)	(acre-feet)
Oct 01	30	0	0	30	93	0	0
Oct 02	30	0	0	30	104	0	0
Oct 03	30	0	0	30	108	0	0
Oct 04	30	0	0	30	100	0	0
Oct 05	30	0	0	30	99	0	0
Oct 06	30	0	0	30	100	0	0
Oct 07	30	0	0	30	119	0	0
Oct 08	30	0	0	30	101	0	0
Oct 09	30	0	0	30	102	0	0
Oct 10	30	0	0	30	108	0	0
Oct 11	30	0	0	30	122	0	0
Oct 12	30	0	0	30	124	0	0
Oct 13	30	0	0	30	138	0	0
Oct 14	30	0	0	30	146	0	0
Oct 15	30	220	436	250	312	220	436
Oct 16	85	350	1,131	435	481	350	1,131
Oct 17	85	625	2,370	710	702	617	2,354
Oct 18	85	625	3,610	710	747	625	3,594
Oct 19	85	625	4,850	710	787	625	4,834
Oct 20	85	625	6,089	710	810	625	6,073
Oct 21	85	625	7,329	710	815	625	7,313
Oct 22	85	625	8,569	710	760	625	8,553
Oct 23	85	625	9,808	710	745	625	9,792
Oct 24	85	390	10,582	475	543	390	10,566
Oct 25	85	240	11,058	325	420	240	11,042
Oct 26	85	120	11,296	205	335	120	11,280
Oct 27	85	120	11,534	205	303	120	11,518
Oct 28	85	120	11,772	205	296	120	11,756
Oct 29	85	120	12,010	205	280	120	11,994
Oct 30	85	120	12,248	205	258	120	12,232
Oct 31	85	120	12,486	205	224	120	12,470



APPENDIX C

Chinook Salmon Survival Investigations

C-1. WATER TEMPERATURE MONITORING LOCATIONS DURING THE VAMP 2003 EXPERIMENT
SACRAMENTO-SAN JOAQUIN ESTUARY

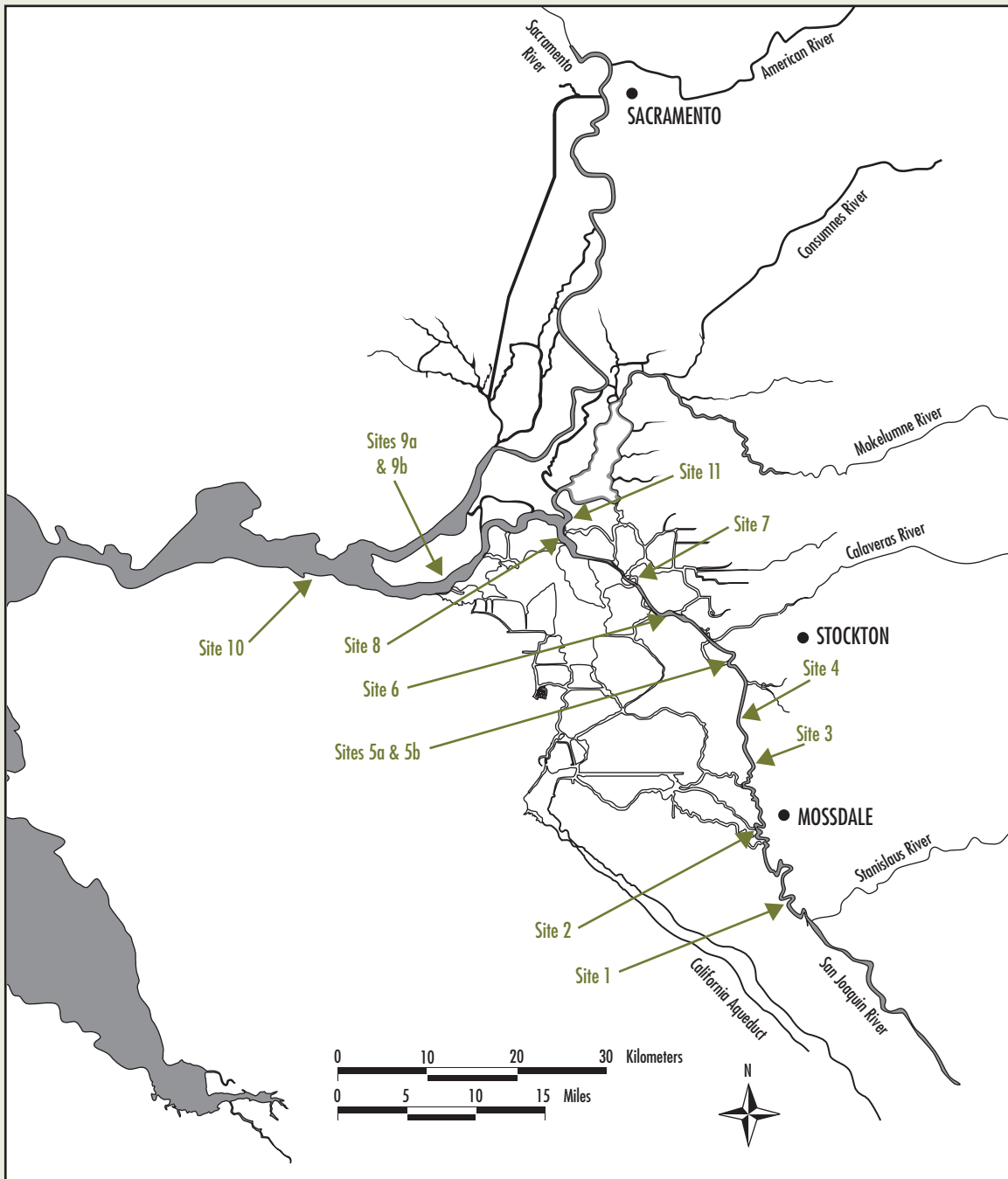

C-1. VAMP 2003 WATER TEMPERATURE MONITORING LOCATIONS

Temperature Monitoring Location	Latitude	Longitude	Distance from Durham Ferry (mi)	Date Deployed	Date Retrieved	Notes
Merced River Hatchery-1			n/a	March 21	April 23	In river April 21
Merced River Hatchery-1			n/a	March 21	April 30	In river April 28
1 Durham Ferry	N 37 41.381	W 121 15.657	n/a	April 11	June 15	Logger was buried in silt when retrieved
2 Mossdale	N 37 47.180	W 121 18.425	11.2	April 11	June 15	3-1/2 feet below surface
3 Dos Reis	N 37 49.808	W 121 18.665	16.4	April 11	June 15	3 feet below surface
4 DWR Monitoring Station	N 37 51.869	W 121 19.376	19.4	April 11	June 15	3 feet below surface
5a Confluence-Top	N 37 56.818	W 121 20.285	26.5	April 11	Logger Malfunction	3 feet below surface
5b Confluence-Bottom	N 37 56.818	W 121 20.285	26.5	April 11		Located on bottom
6 Downstream of Channel Marker 30	N 37 59.776	W 121 25.569	33.3	April 11	June 15	3 feet below surface
7 1/2 mile Upstream of Channel Marker 13	N 38 01.940	W 121 28.769	37.3	April 11	June 15	3 feet below surface
8 Downstream of Channel Marker 36	N 38 04.522	W 121 34.413	44.7	April 11	June 15	3 feet below surface
9a Jersey Point USGS Gauging Station-top	N 38 03.172	W121 41.637	56	April 11	Logger Lost	3 feet below surface
10 Chipps Island	N 38 03.084	W 121 55.463	71.5	April 11	June 15	4-1/2 feet below surface
11 Mokelumne River-Lighthouse Marina	N 38 06.334	W 121 34.213	40	April 11	June 15	Under pier in 3 feet of water

C-2. WATER TEMPERATURE MONITORING

Site 1 • Durham Ferry

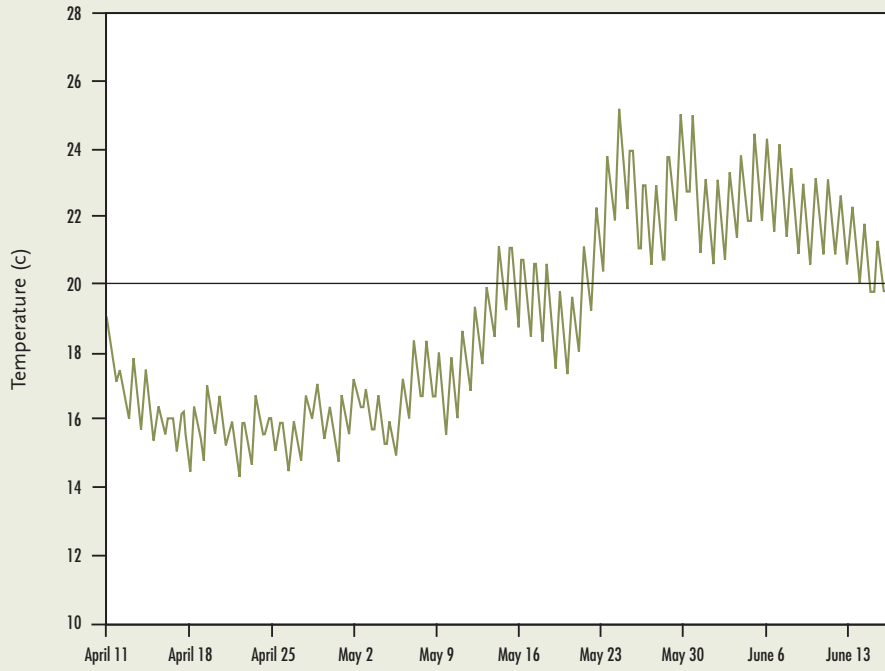

Site 2 • Mossdale

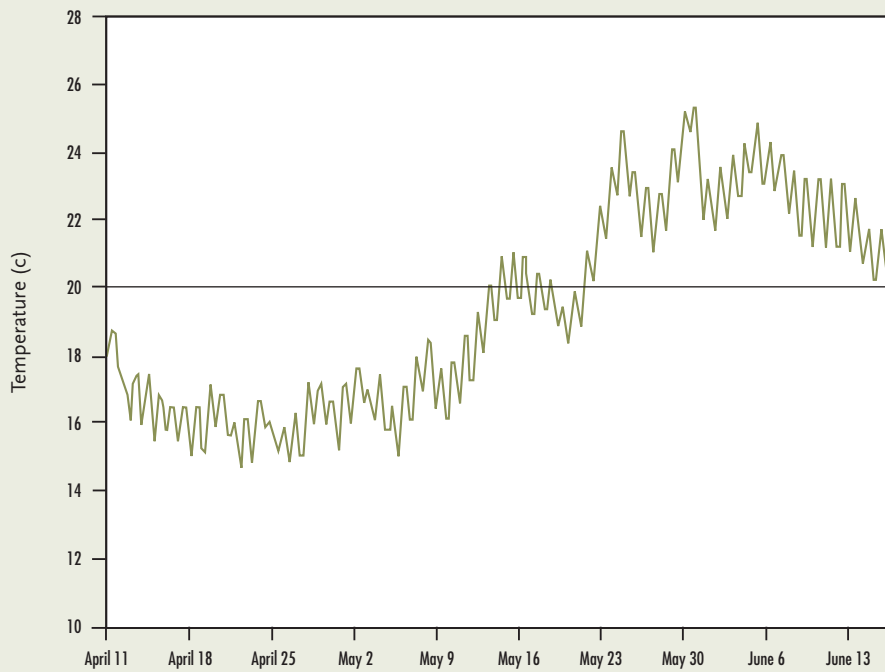

C-2. WATER TEMPERATURE MONITORING

Site 3 • Dos Reis

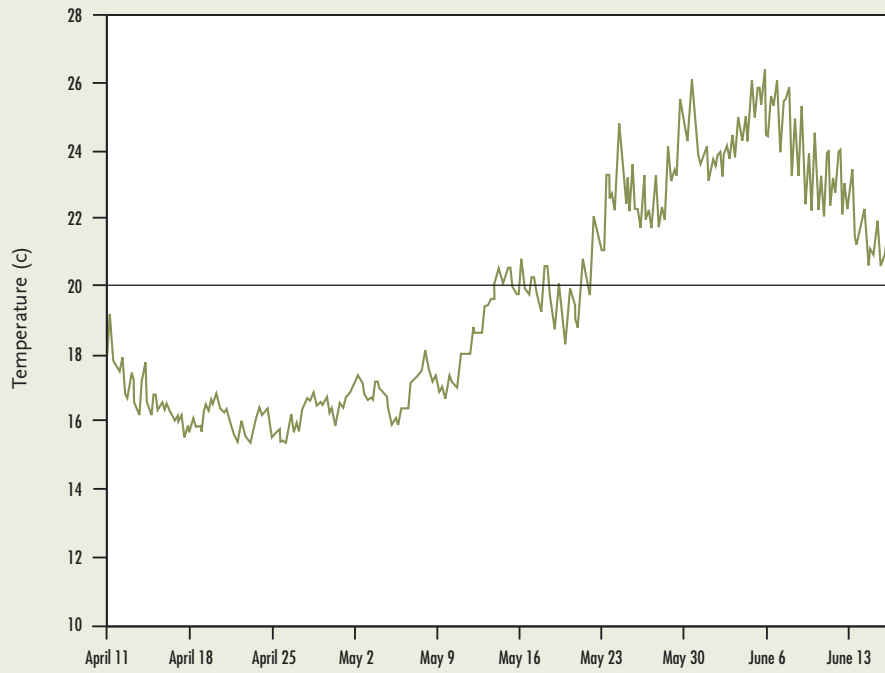

Site 4 • DWR Monitoring Station

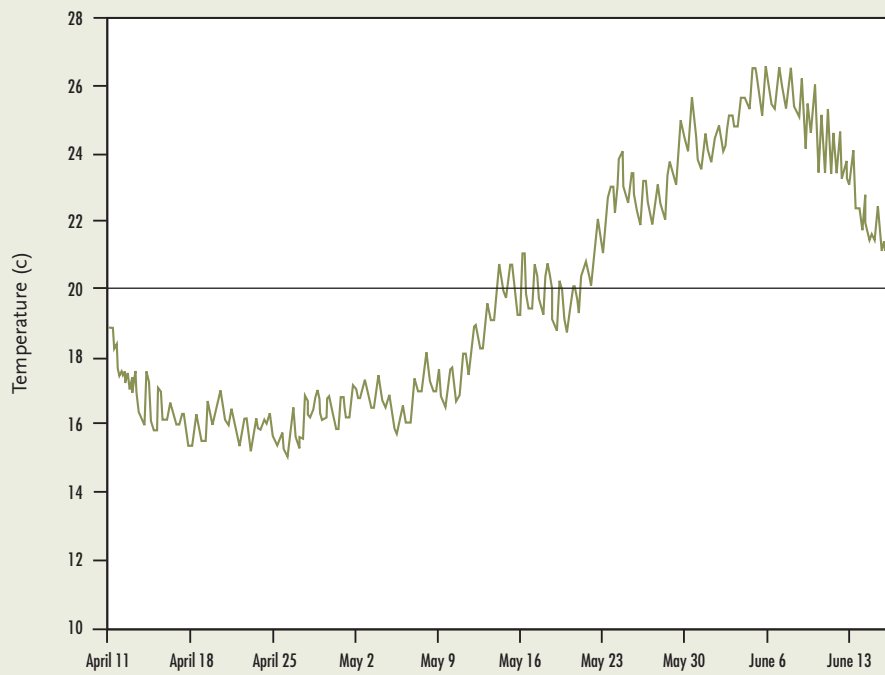

C-2. WATER TEMPERATURE MONITORING

Site 5b • Confluence-Bottom

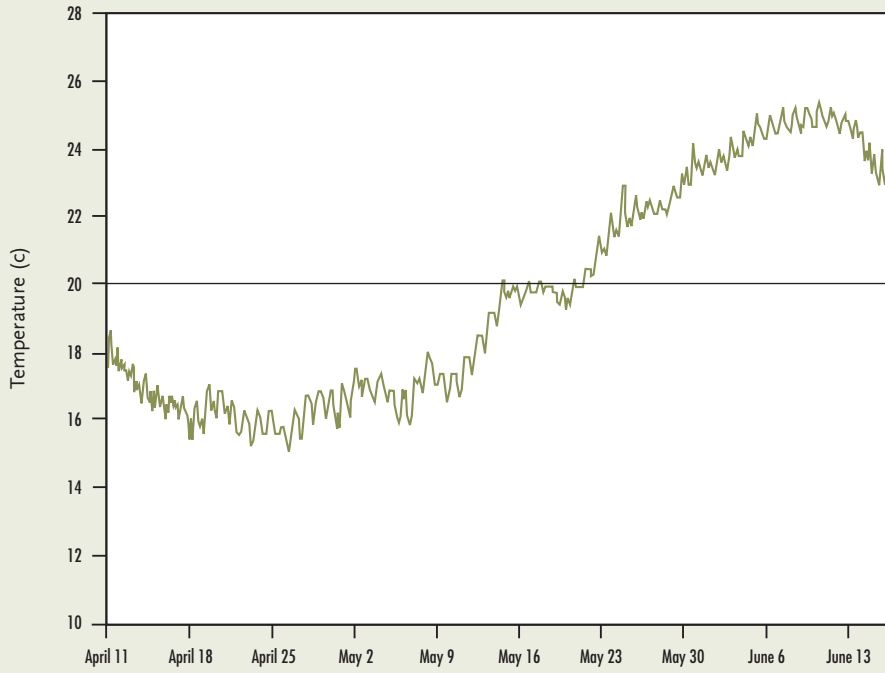

Site 6 • Downstream of Channel Marker 30

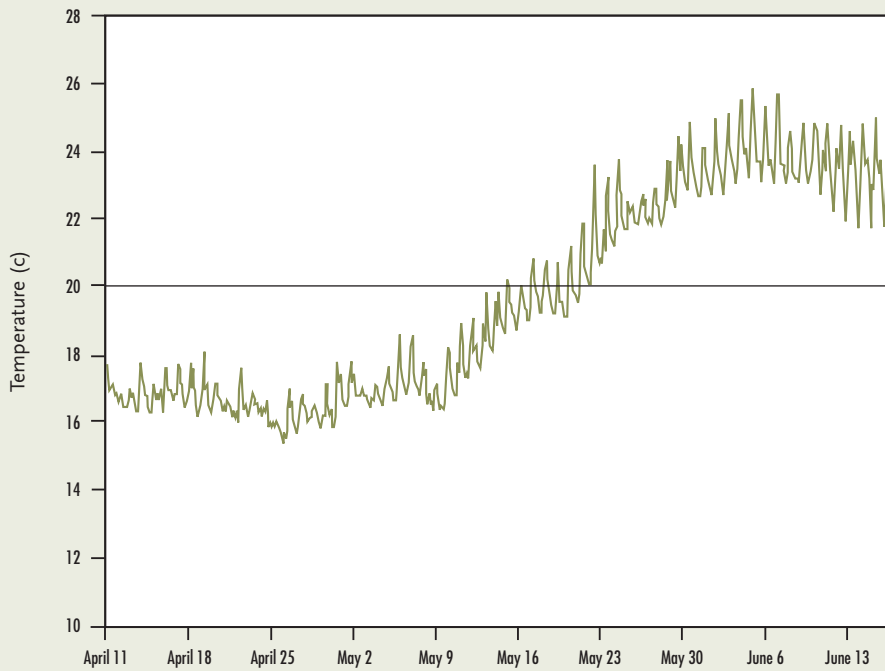

C-2. WATER TEMPERATURE MONITORING

Site 7 • 1/2 Mile Upstream of Channel Marker 13

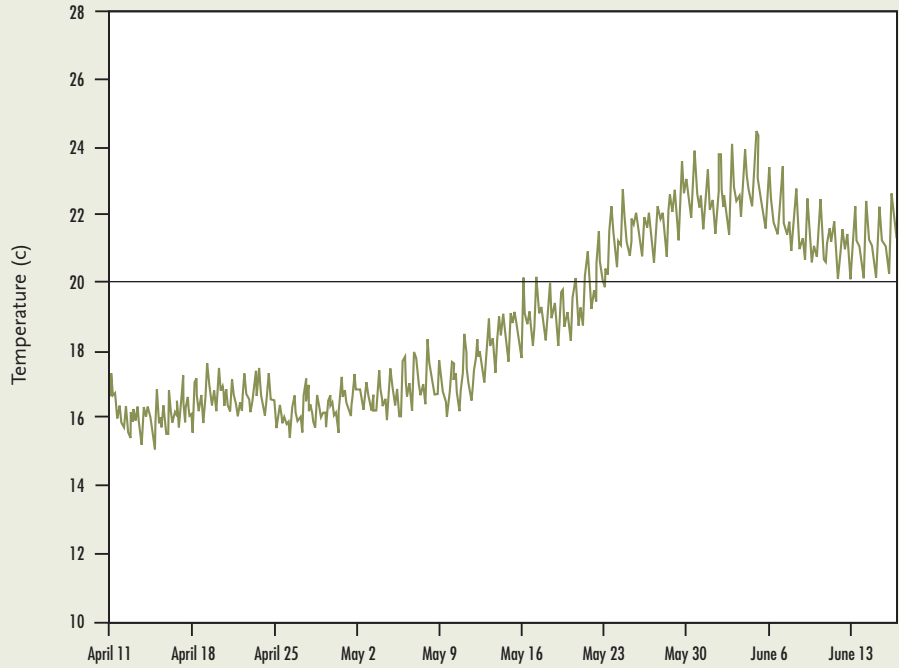

Site 8 • Downstream of Channel Marker 36

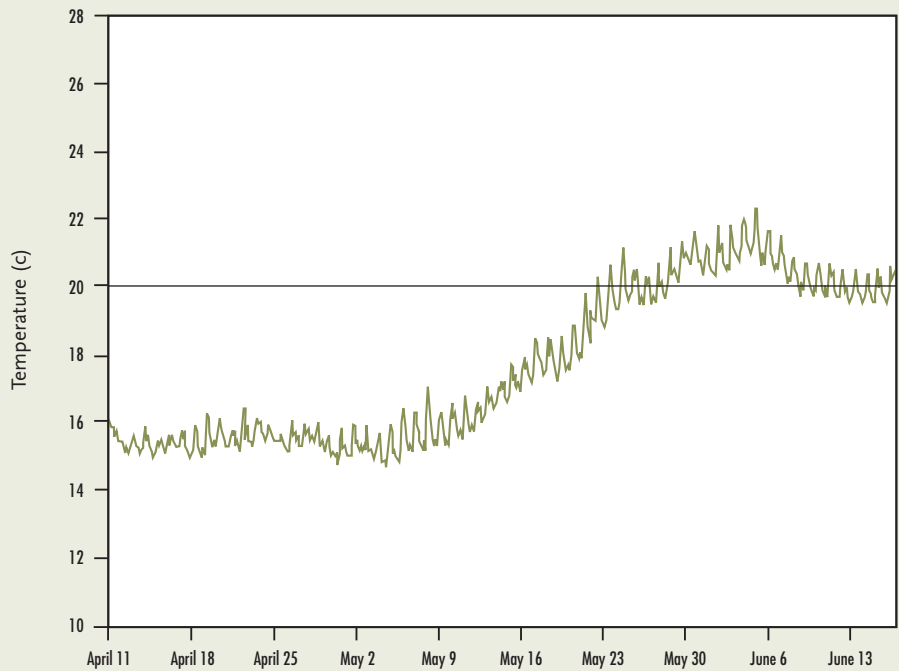

C-2. WATER TEMPERATURE MONITORING

Site 10 • Chipps Island

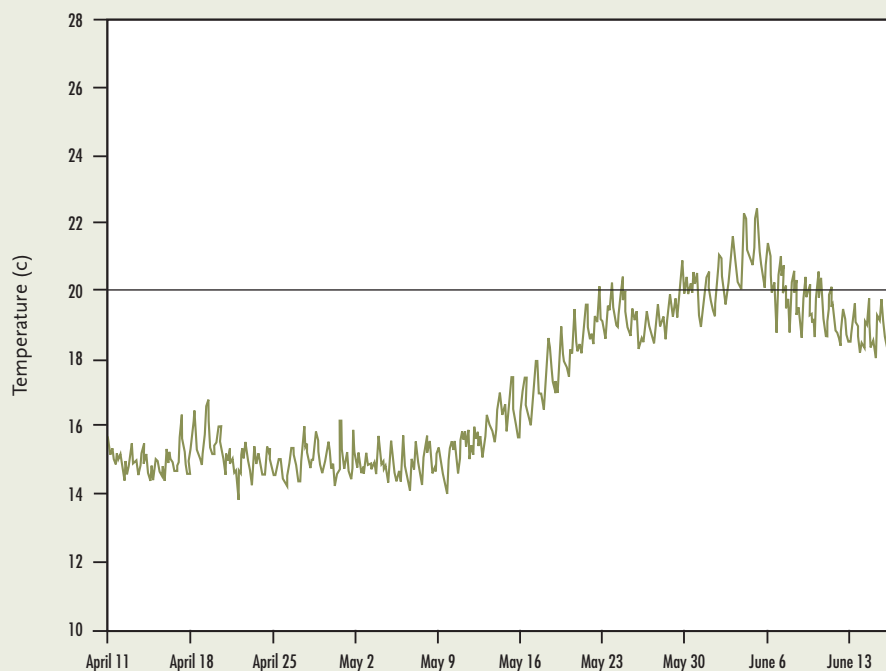

C-3. RESULTS OF NET PEN SAMPLING

a. Conducted After First Set Juvenile Chinook Salmon Releases, VAMP 2003

	Release Date	Release Location and Number	Coded-wire tag codes(s)	Number in sample	Mean fork length (and range in mm)	Mean weight (and range in g)	Mean scale loss (and range in %)
Samples at 00 Hours	21 Apr	Durham Ferry I ¹	06-02-82 06-02-83 06-27-42	50	85 (72-96)	6.6 (4.2-9.2)	9 (3-25)
	22 Apr	Mossdale I	06-27-43 06-27-48	25 25	86 (74-101) 88 (78-92)	6.9 (4.3-12.1) 7.0 (4.5-9.2)	3 (1-6) 3 (1-8)
	25 Apr	Jersey Point I	06-27-44	25	89 (77-98)	7.5 (4.9-9.9)	3 (2-6)
Samples at 48 Hours	21 Apr	Durham Ferry I ^{1,2}	06-02-82 06-02-83 06-27-42	265	86 (68-99)	6.7 (3.3-10.3)	11 (5-30)
	22 Apr	Mossdale I ²	06-27-43 06-27-48	234 267	88 (72-104) 85 (65-99)	7.2 (3.7-12.0) 7.1 (3.0-10.7)	8 (4-15) 7 (3-15)
	25 Apr	Jersey Point I ²	06-27-44	200	88 (69-103)	7.5 (2.7-11.3)	4 (2-10)

¹ Coded-wire tag codes for Durham Ferry releases were combined at the hatchery, so reported values are for all three tag codes.

² Color, fin hemorrhaging, eye appearance, and gill color were assessed from the first 25 fish for Mossdale and Jersey Point releases at 48 hours. These characteristics were assessed using the first 50 fish from the first Durham Ferry release at 48 hours.

Site 1 • Mokelumne River

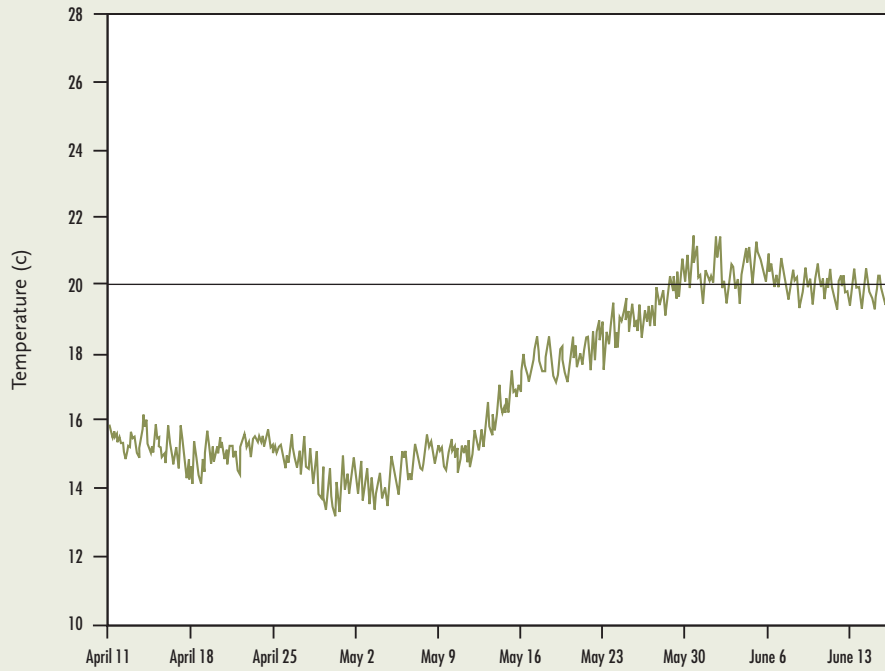

Color (% normal)	Fin Hemorrhaging (% none)	Eye appearance (% normal)	Gill color (% normal)	Missing adipose fin clips (%)	Partial adipose fin clips (%)	Number of mortalities	Other deformities and comments
98	100	100	100	0	10	0	2 fish had ragged dorsal fins
100	100	100	100	4	8	0	1 fish with stunted pectoral fin and partial operculum
100	100	100	100	0	0	0	
100	100	100	96	0	0	0	
100	100	98	100	1.5	9.4	1	2 fish with caudal fin rot, 1 fish with left eye missing, 5 fish with ragged fins, 1 fish with partial operculum
100	100	96	96	1.7	10.7	1	1 fish with a split dorsal fin, 2 fish with a partial operculum
100	100	100	96	0.4	1.9	0	
100	100	100	96	0.0	0.5	7	26 additional fish were released on 4/27/03 without being measured

C-3. RESULTS OF NET PEN SAMPLING

b. Conducted After Second Set Juvenile Chinook Salmon Releases, VAMP 2003

	Release Date	Release Location and Number	Coded-wire tag codes(s)	Number in sample	Mean fork length (and range in mm)	Mean weight (and range in g)	Mean scale loss (and range in %)
Samples at 00 Hours	28 Apr	Durham Ferry II ¹	06-27-45 06-27-46 06-27-47	50	87 (73-93)	6.9 (3.7-8.4)	14 (3-35)
	29 Apr	Mossdale II	06-27-49 06-27-50	25 25	86 (78-92) 88 (78-92)	7.0 (4.4-9.7) 7.3 (4.8-8.7)	12 (5-35) 12 (3-25)
	2 May	Jersey Point II	06-27-51	25	88 (79-97)	7.3 (5.0-9.5)	19 (10-35)
Samples at 48 Hours	28 Apr	Durham Ferry II ^{1,2}	06-27-45 06-27-46 06-27-47	358	87 (73-100)	6.9 (3.6-10.4)	3 (1-5)
	29 Apr	Mossdale II ²	06-27-49 06-27-50	33 144	89 (73-98) 88 (70-102)	7.5 (3.9-9.4) 7.3 (3.8-10.4)	10 (5-20) 14 (5-30)
	2 May	Jersey Point II ²	06-27-51	236	90 (71-102)	7.8 (4.0-11.3)	4 (2-10)

¹ Coded-wire tag codes for Durham Ferry releases were combined at the hatchery, so reported values are for all three tag codes.

² Color, fin hemorrhaging, eye appearance, and gill color were assessed from the first 25 fish for Mossdale and Jersey Point releases at 48 hours. These characteristics were assessed using the first 49 fish from the second Durham Ferry release at 48 hours.

C-4. VAMP 2003 CODED-WIRE TAG RECOVERIES

The following graphs are of coded-wire tagged juvenile chinook salmon, from the two sets of VAMP 2003, releases recovered during trawling at Antioch. No coded-wire tagged juveniles were recovered at Antioch from the second Durham Ferry release (on April 28, 2003) or the second Mossdale release (on April 29, 2003).

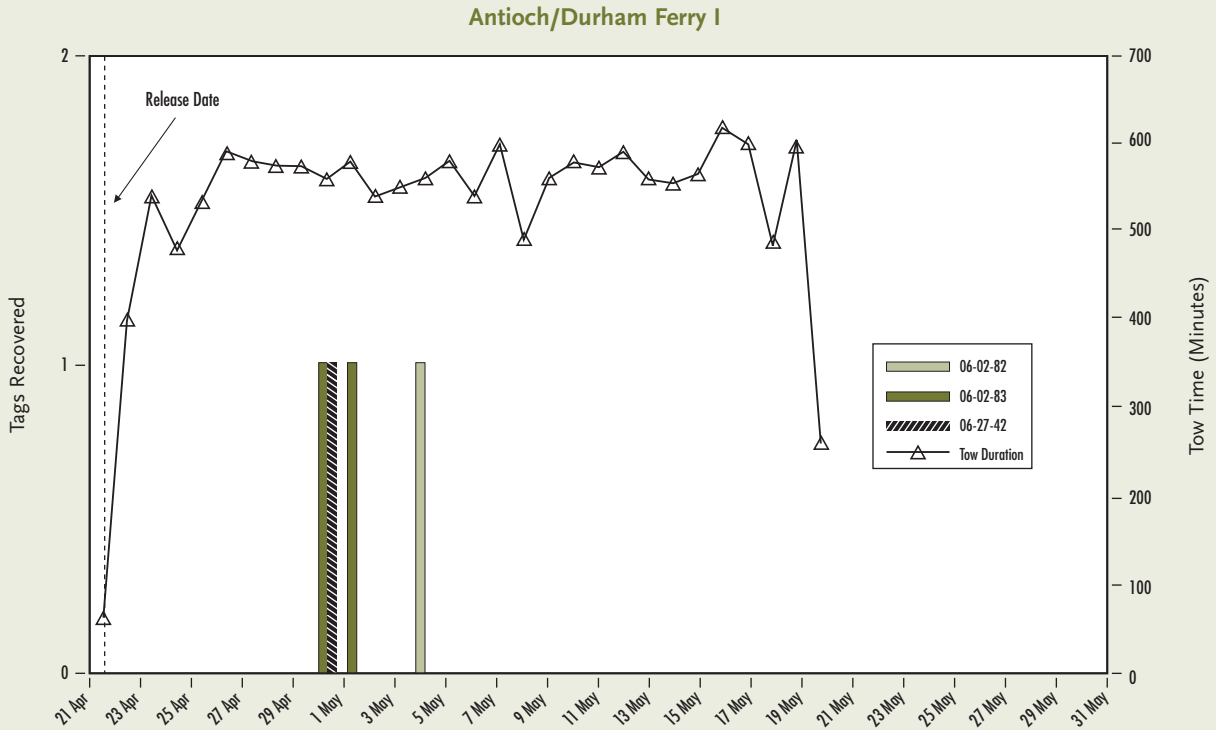

Color (% normal)	Fin Hemorrhaging (% none)	Eye appearance (% normal)	Gill color (% normal)	Missing adipose fin clips (%)	Partial adipose fin clips (%)	Number of mortalities	Other deformities and comments
100	100	98	98	2	2	0	
100	100	100	88	0	8	0	left eye was missing
100	100	96	100	4	0	0	
100	100	100	88	4	8	0	
100	100	100	98	0.0	1.7	2	small holes in net pen may have allowed fish to escape
100	100	100	100	0	0	0	
100	100	100	100	0.7	3.5	0	
100	100	100	100	0.8	3.4	0	

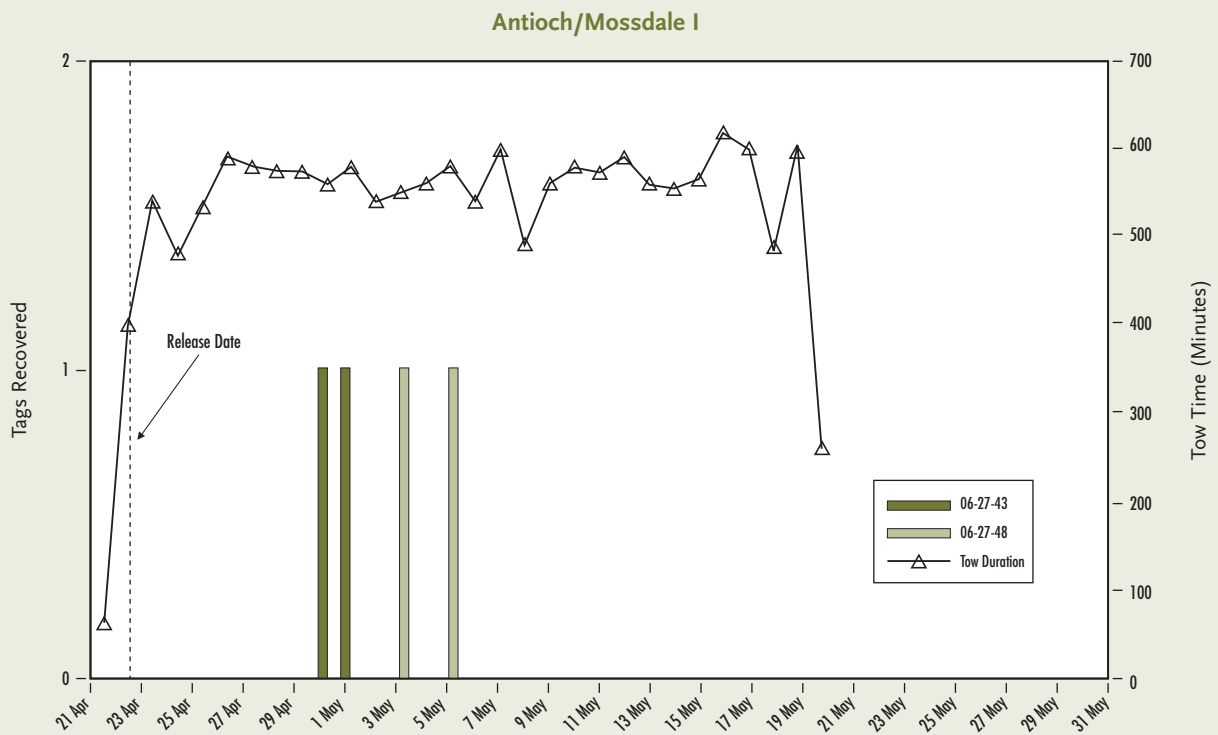

C-4. VAMP 2003 CODED-WIRE TAG RECOVERIES

Antioch/Jersey Point I

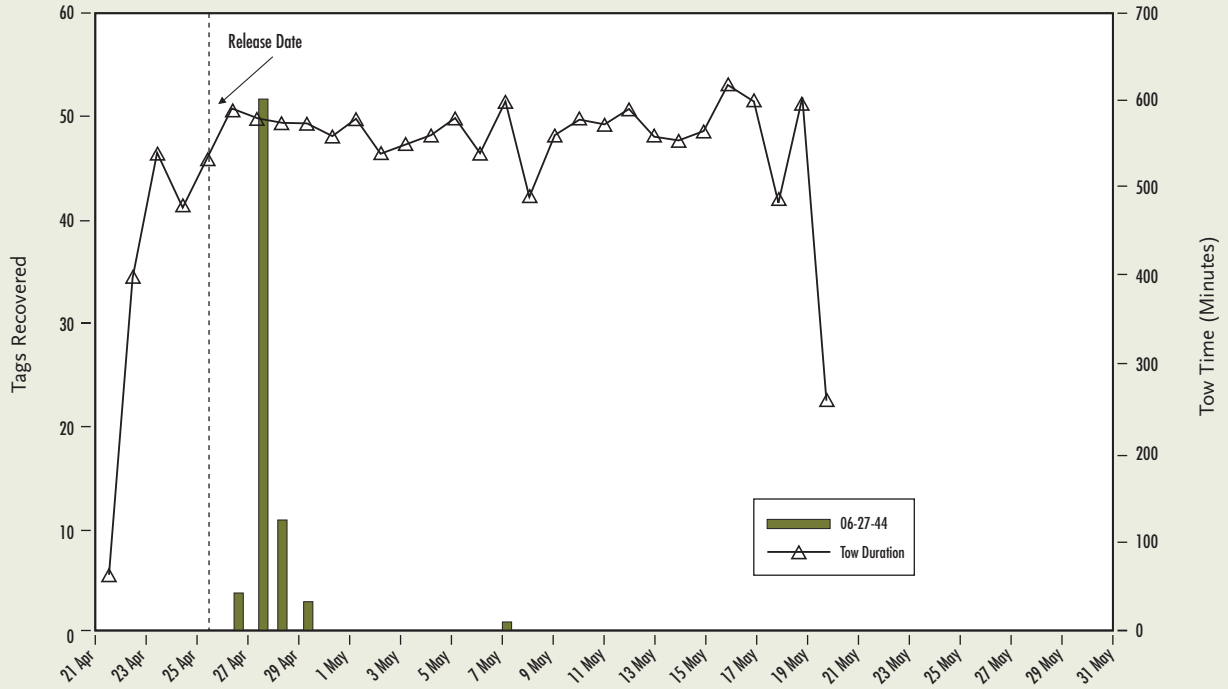

Antioch/Jersey Point II

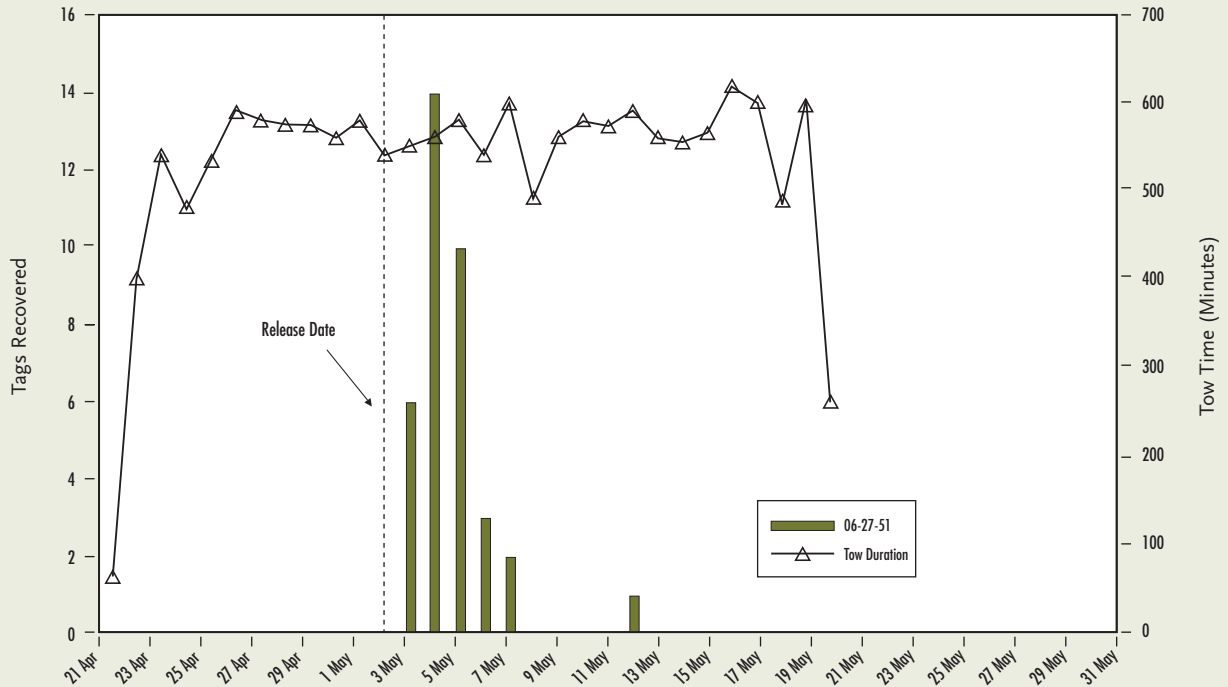

C-4. VAMP 2003 CODED-WIRE TAG RECOVERIES

The following graphs are of coded-wire tagged juvenile chinook salmon, from the two sets of VAMP 2003, releases recovered during trawling at Chipps Island. No coded-wire tagged juveniles were recovered at Chipps Island from the second Durham Ferry release (on April 28, 2003).

Chipps Island/Durham Ferry I

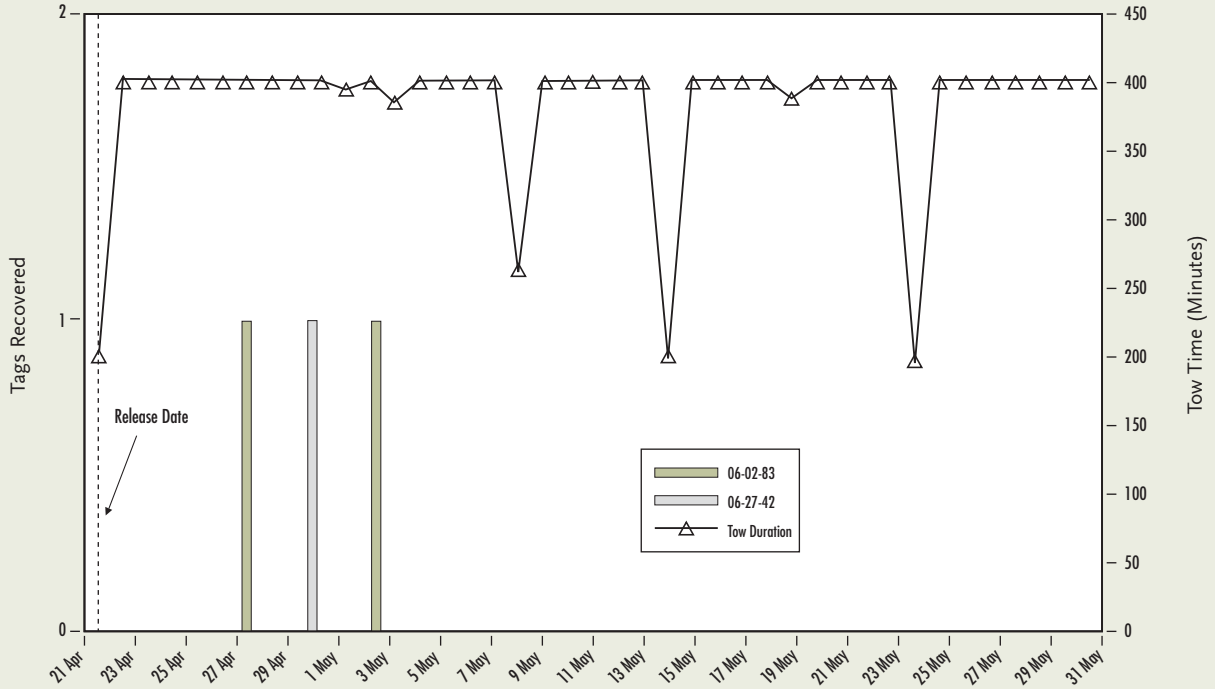

Chipps Island/Mossdale I

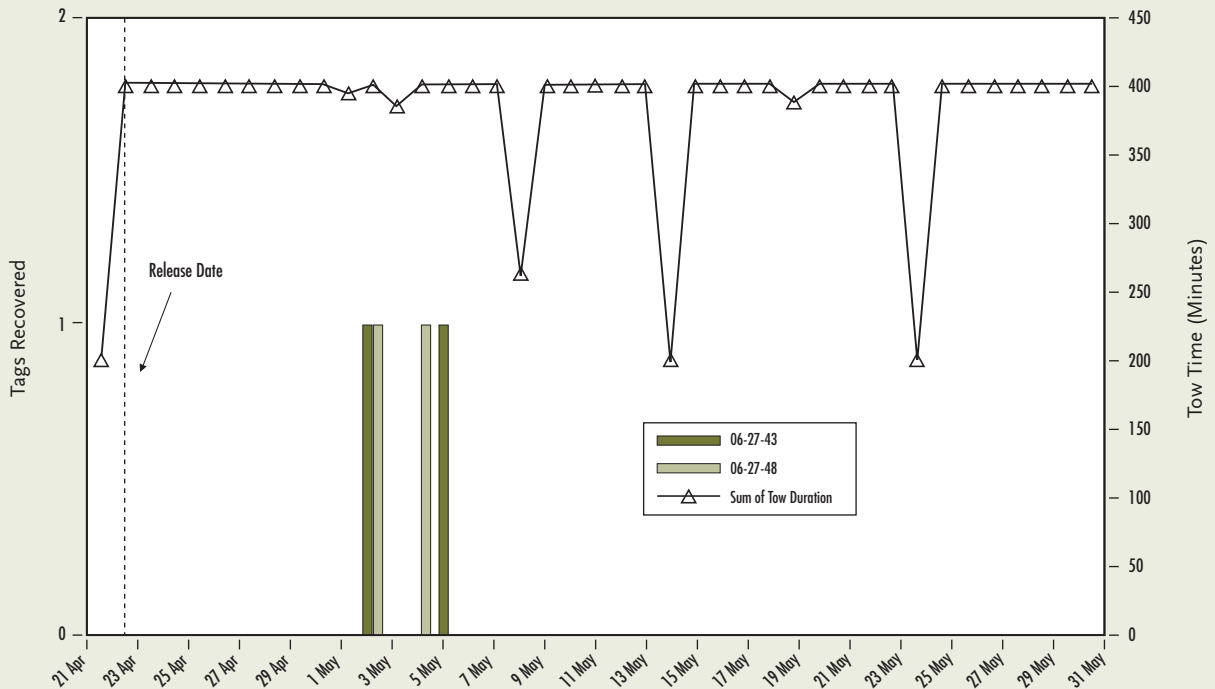

C-4. VAMP 2003 CODED-WIRE TAG RECOVERIES

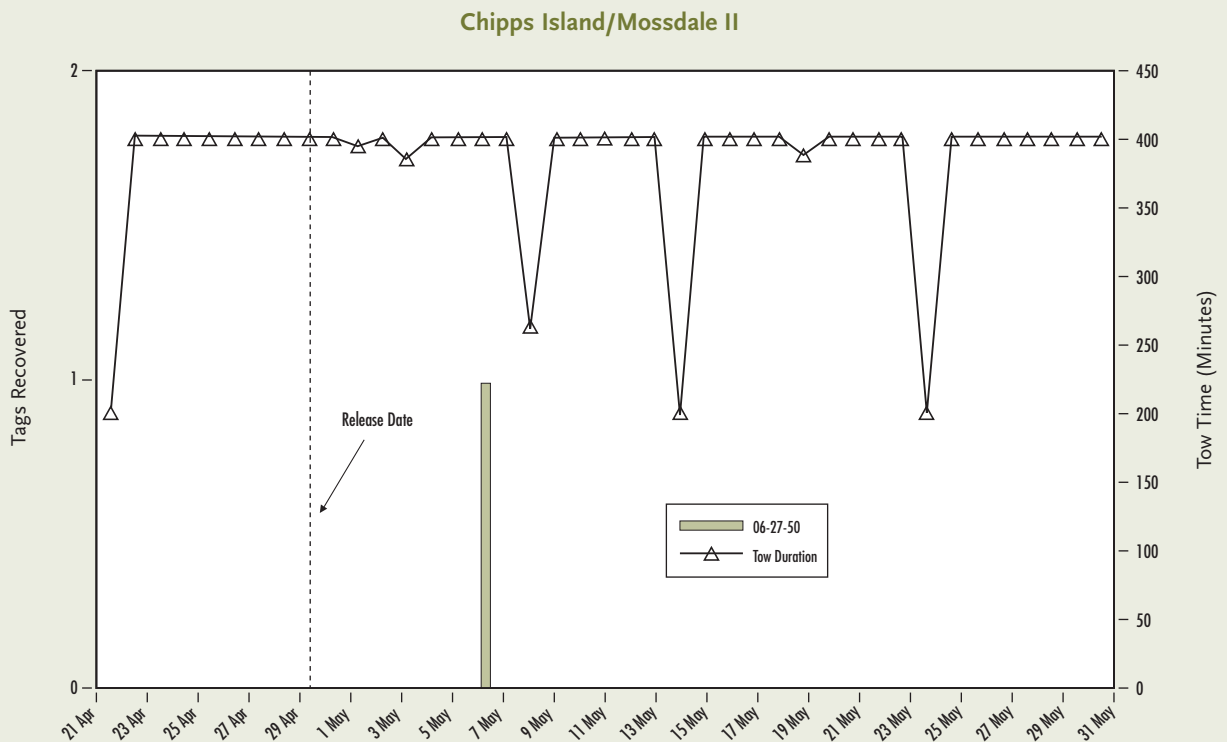
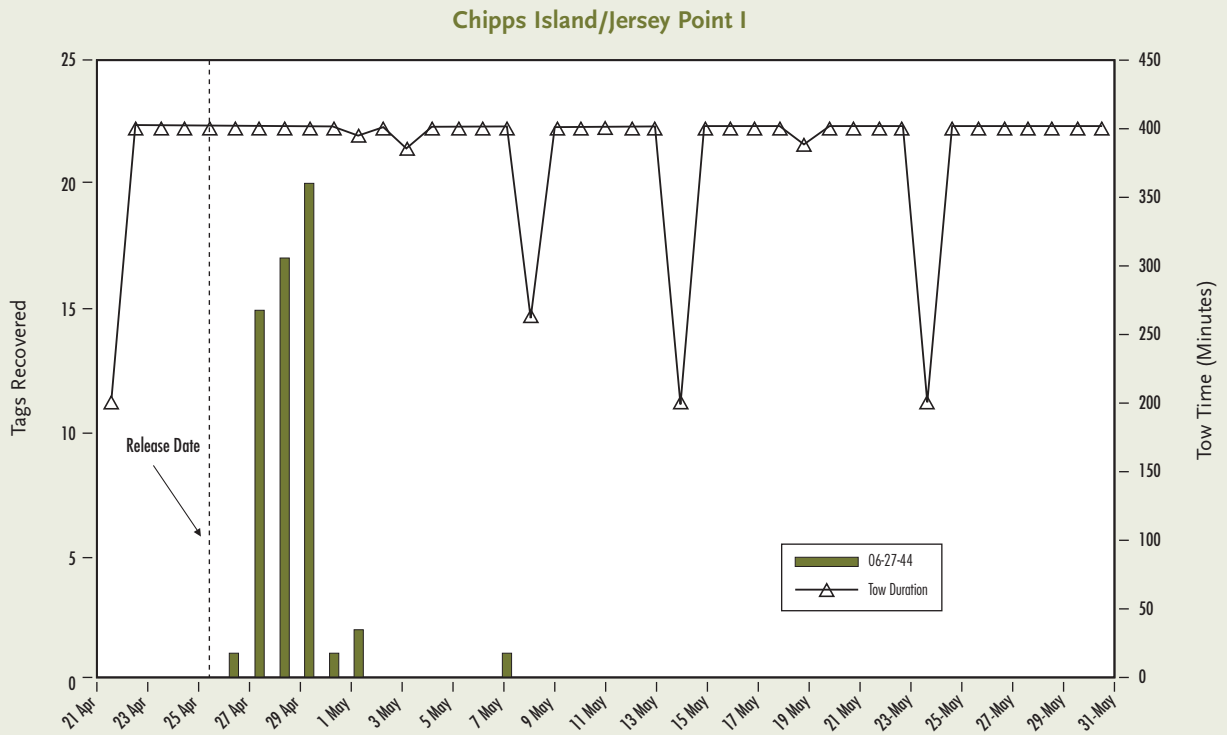

C-4. VAMP 2003 CODED-WIRE TAG RECOVERIES

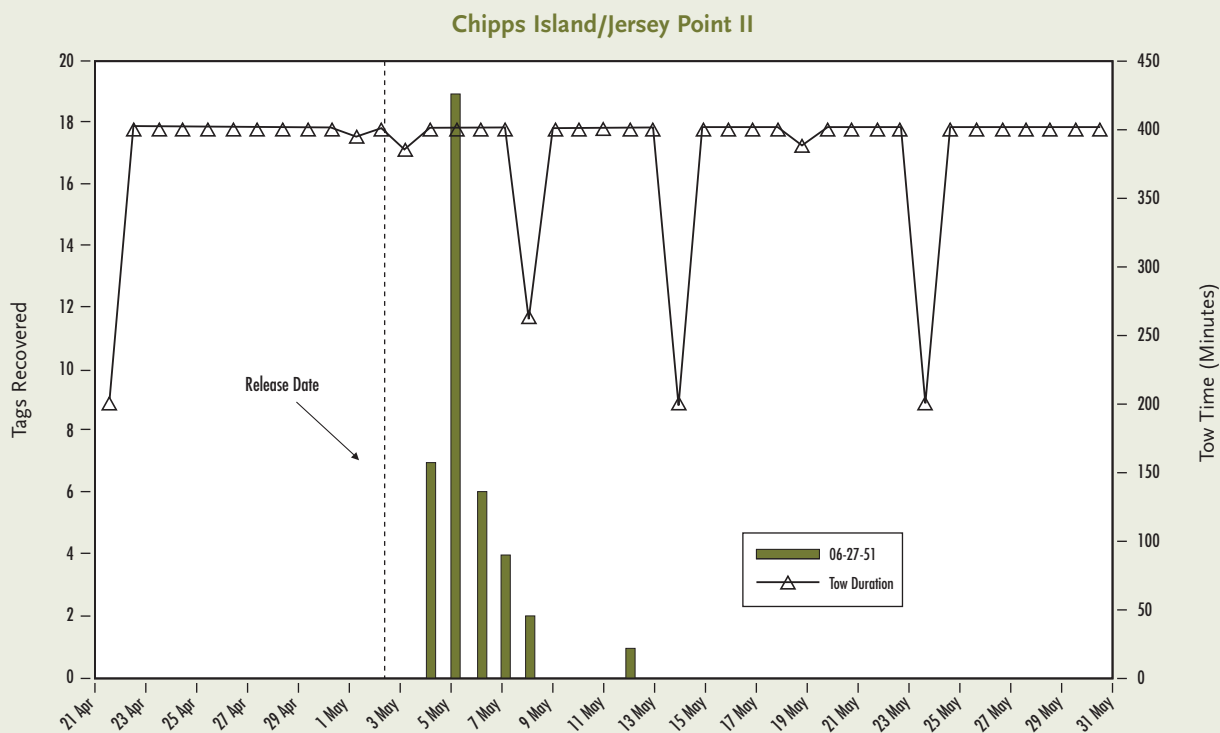

**C-5. RECOVERY TIMING OF CWT RELEASED AS
SAN JOAQUIN TRIBUTARY STUDIES IN 2003**

	Tag code	Release Site/Release Stock	Release Date	Antioch			Chippis Island		
				First day recovered	Last day recovered	Days at large	First day recovered	Last day recovered	Days at large
Merced River	06-44-89	Merced River Fish Facility	4/13/03	4/24/03	4/27/03	14	4/25/03	4/25/03	12
	06-44-90	Merced River Fish Facility		4/26/03	4/26/03	13	4/23/03	4/23/03	10
	06-44-91	Merced River Fish Facility		4/26/03	5/04/03	21	—	—	—
	06-44-92	Merced River Fish Facility		—	—	—	4/29/03	4/29/03	16
	Total			4/24/03	5/04/03	21	4/23/03	4/29/03	16
	06-44-93	Hatfield State Park (lower Merced)	4/16/03	4/24/03	4/27/03	11	4/24/03	4/26/03	10
	06-44-94	Hatfield State Park (lower Merced)		4/25/03	5/03/03	17	4/26/03	4/26/03	10
	06-44-95	Hatfield State Park (lower Merced)		4/23/03	4/26/03	10	4/25/03	5/05/03	19
	Total			4/23/03	5/03/03	17	4/24/03	5/05/03	19
	06-44-96	Merced River Fish Facility	4/25/03	—	—	—	—	—	—
	06-44-97	Merced River Fish Facility		—	—	—	—	—	—
	06-44-98	Merced River Fish Facility		5/11/03	5/11/03	16	—	—	—
	06-44-99	Merced River Fish Facility		—	—	—	—	—	—
	Total			5/11/03	5/11/03	16	—	—	—
06-45-64	Hatfield State Park (lower Merced)	4/29/03	—	—	—	—	—	—	
06-45-65	Hatfield State Park (lower Merced)		—	—	—	5/07/03	5/10/03	11	
06-45-66	Hatfield State Park (lower Merced)		5/12/03	5/12/03	13	—	—	—	
Total			5/12/03	5/12/03	13	5/07/03	5/10/03	11	
06-27-77	Merced River Fish Facility	5/04/03	—	—	—	5/20/03	5/20/03	16	
06-27-78	Merced River Fish Facility		—	—	—	—	—	—	
06-44-49	Merced River Fish Facility		5/18/03	5/18/03	14	5/17/03	5/17/03	13	
06-44-50	Merced River Fish Facility		—	—	—	5/15/03	5/18/03	14	
Total			5/18/03	5/18/03	14	5/15/03	5/20/03	16	
06-45-46	Hatfield State Park (lower Merced)	5/07/03	—	—	—	5/17/03	5/17/03	10	
06-45-47	Hatfield State Park (lower Merced)		5/15/03	5/17/03	10	—	—	—	
06-45-72	Hatfield State Park (lower Merced)		—	—	—	5/15/03	5/15/03	8	
Total			5/15/03	5/17/03	10	5/15/03	5/17/03	10	
Stanislaus River	06-45-67	Knight's Ferry	4/25/03	5/17/03	5/17/03	22	—	—	—
	06-45-68	Knight's Ferry		—	—	—	5/11/03	5/11/03	16
	06-45-69	Knight's Ferry		5/04/03	5/04/03	9	—	—	—
	Total			5/04/03	5/17/03	22	5/11/03	5/11/03	16
	06-45-70	Two Rivers	4/27-4/28/03	5/05/03	5/05/03	8	—	—	—
06-45-71	Two Rivers	5/07/03		5/12/03	15	—	—	—	
Total		5/05/03		5/12/03	15	—	—	—	



APPENDIX D

Errata

ERRATA FOR THE YEAR 2002 ANNUAL TECHNICAL REPORT

On Implementation and Monitoring of the San Joaquin River Agreement and the Vernalis Adaptive Management Plan

1. Page 38: VAMP Chinook Salmon CWT Survival Indices, 2nd Sentence: Should be replaced with “Survival indices were calculated by dividing the number of CWT salmon recovered by the product of the effective number released (E) multiplied by the fraction of time (T) and channel Width (W) sampled as shown by the formula: $SI = R / (E * T * W)$.”
2. Page 54, Figure 5-14: Legend should read “Catch per Minute of all Unmarked Juvenile Chinook Salmon in the Mossdale Kodiak Trawl, March 15, 2002 through June 30, 2002.”
3. Page 108–113, Appendix C: The title “Net Pen Sampling Results” should be deleted at the top of each page.

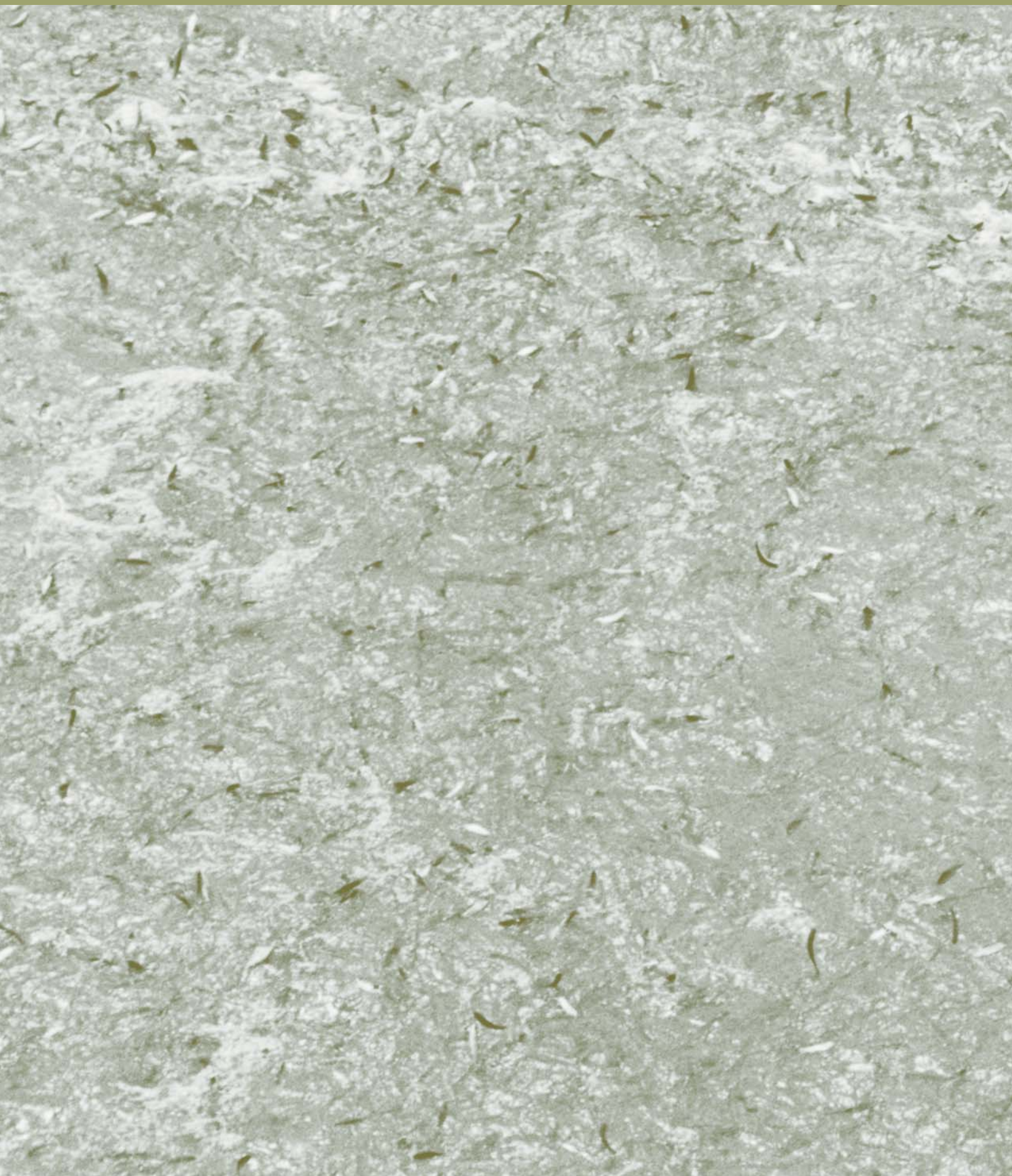

SAN JOAQUIN RIVER GROUP AUTHORITY

**P.O. Box 4060, Modesto, CA 95352
(209) 526-7405 • fax (209) 526-7315**

Modesto Irrigation District

Turlock Irrigation District

Oakdale Irrigation District

Merced Irrigation District

Friant Water Users Authority

City and County of San Francisco

South San Joaquin Irrigation District

San Joaquin River Exchange Contractors